

Manganese Lithium Coin Batteries (ML series): Individual Specifications

ML920S

Dimensions(mm)

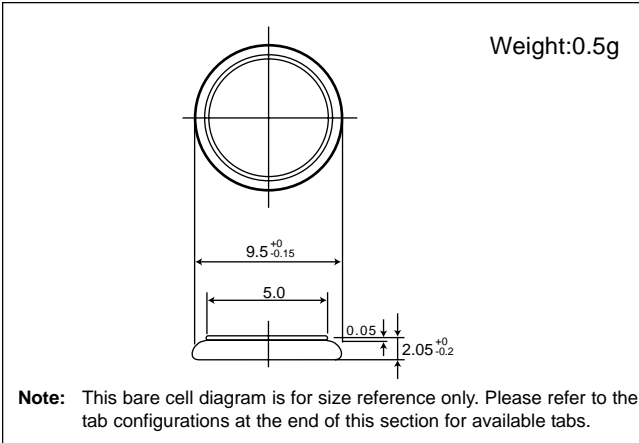

Specification

Nominal voltage (V)	3
Nominal capacity (mAh)	11.0
Continuous standard load (mA)	0.03
Operating temperature (C)	-20 ~ +60

Discharge characteristics

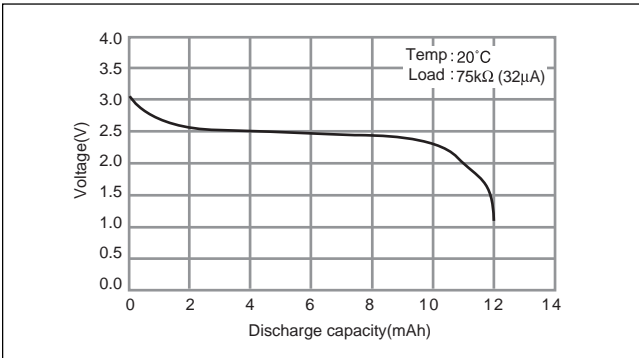

Consumption current vs. Duration time

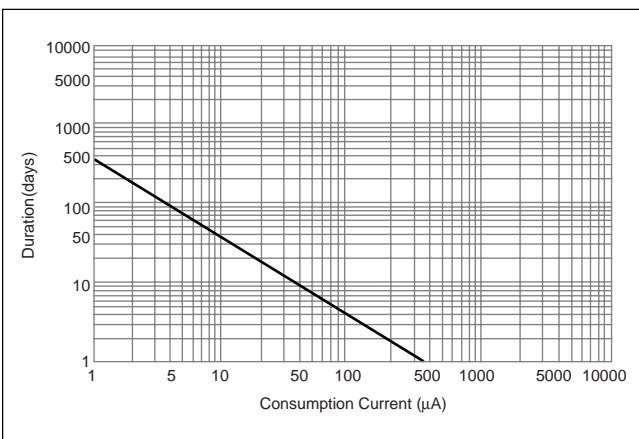

ML1220

Dimensions(mm)

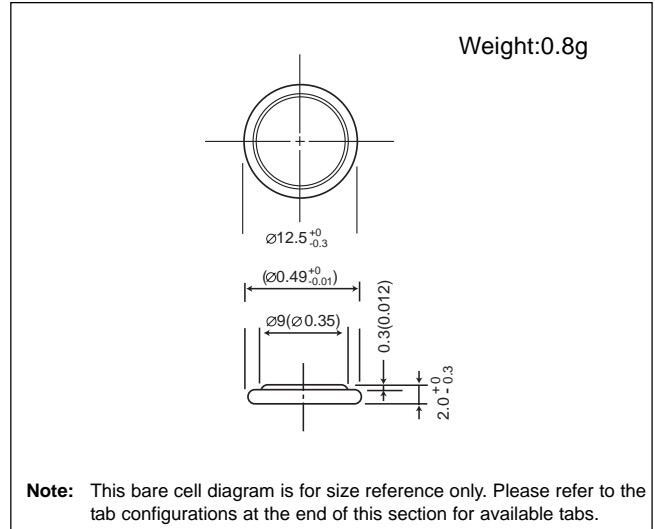

Specification

Nominal voltage (V)	3
Nominal capacity (mAh)	17.0
Continuous standard load (mA)	0.03
Operating temperature (C)	-20 ~ +60

Discharge characteristics

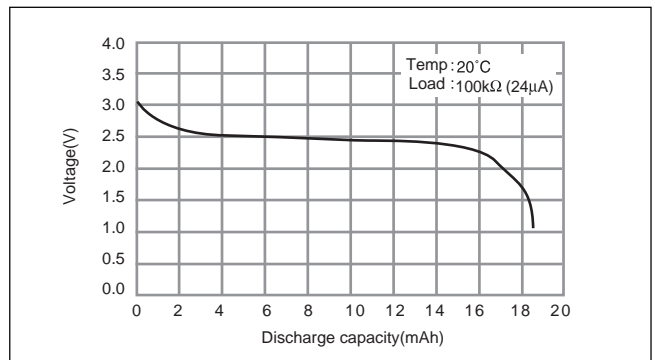

Consumption current vs. Duration time

