

# Manganese Titanium Lithium Rechargeable Batteries (MT series): Individual Specifications

## MT516

Dimensions(mm)

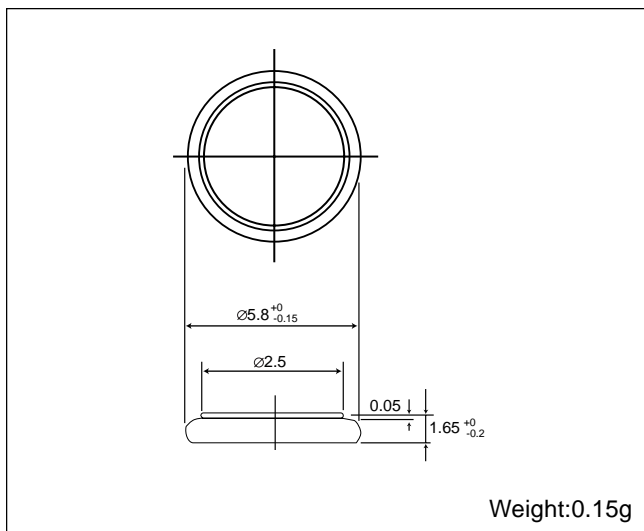

Specification

<b>Nominal voltage (V)</b>	1.5
<b>Nominal capacity (mAh)</b>	0.9
<b>Continuous standard load (mA)</b>	0.05
<b>Operating temperature (C)</b>	-20 ~ +60

Charge / discharge characteristics

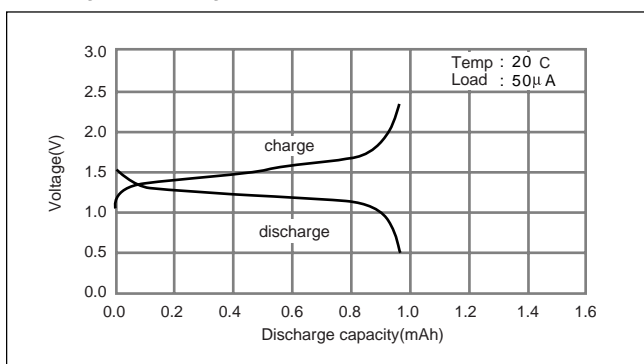

Consumption current vs. Duration time

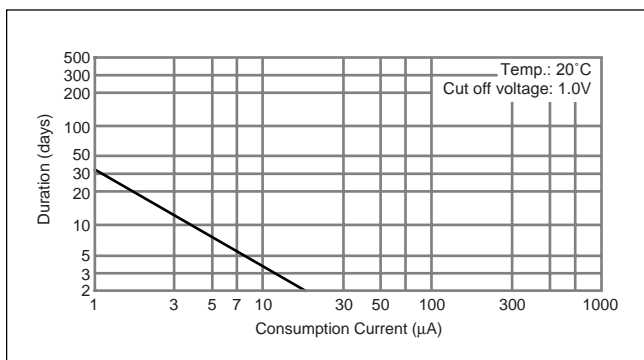

## MT616

Dimensions(mm)

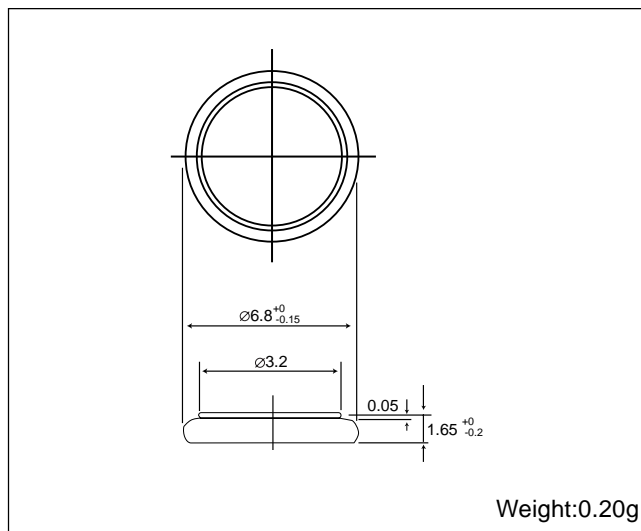

Specification

<b>Nominal voltage (V)</b>	1.5
<b>Nominal capacity (mAh)</b>	1.05
<b>Continuous standard load (mA)</b>	0.05
<b>Operating temperature (C)</b>	-20 ~ +60

Charge / discharge characteristics

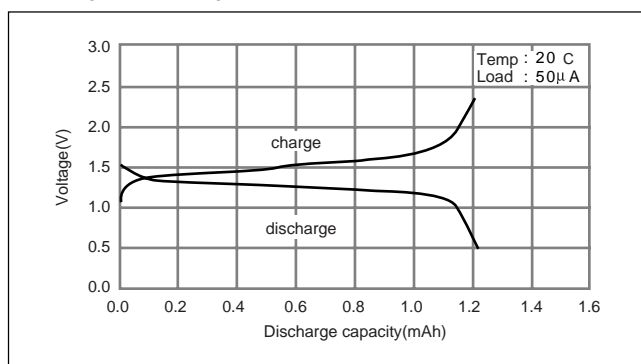

Consumption current vs. Duration time

