

INTRODUCTION

Tantalum capacitors are designed with excellent performance characteristics for filtering, blocking, and R.C tuning circuits. They are used extensively in industrial, commercial, entertainment and medical electronic equipment. They exhibit the proven characteristics of wide temperature range and long-term stability.

The advantages of tantalum capacitor electrolytic capacitor consist of their chemical stability, the low thickness and high dielectric constant of the tantalum oxide layer, and the capability of sintering anodes with a very large surface from tantalum powder.

The low reactivity of the tantalum oxide layer allows the employment of highly conductive electrolytes, and thus achieves a low series resistance. Capacitance and dissipation factor in relation to temperature and frequency thus prove to be very favourable. Additionally, there is also the wide temperature range of several types from -55°C to $+125^{\circ}\text{C}$.

A further advantage of the dielectric being inactive is a leakage current that is smaller than of aluminium electrolytic capacitor which does not rise considerably even at dead storage. Tantalum electrolytic capacitor thus show a very long life during operation and storage.

The capacitance of the tantalum electrolytic capacitor is very high due to the high dielectric constant and the low thickness of tantalum oxide layer. The use of sintered anodes with a large surface allows very small dimensions that can not be reached or exceeded by any other capacitor.

The tantalum electrolytic capacitor at issue are polarized capacitors. In the case of polarized electrolytic capacitor, the dielectric is structured in such a manner that the flow of current is interrupted in one direction. It is therefore necessary to observe the indications regarding polarity when using these capacitors (positive pole on anode and negative pole on cathode). In the case of tantalum capacitor, a mispolarizing is permissible up to the values indicated in reversal voltage.

The tantalum capacitor is a polar electrolytic capacitor. The anode is a porous body of sintered tantalum powder. A layer of tantalum oxide is formed over the whole sintered anode surface by an electrolytic oxidation process.

This oxide layer, which has a high dielectric constant ($\epsilon \approx 27$), functions as the dielectric medium of the capacitor. The final thickness of the layer determines the rated working voltage of the capacitor. Manganese dioxide, a solid semiconducting electrolyte, is deposited in the pores and on the external surface of the formed anode to serve as the cathode. Electrical connection to the cathode is effected by applying a metallic coating to the outer MnO_2 layer.

As a result of the high stability of the oxide layer the leakage current to the capacitor is very small, even after prolonged storage. The use of a solid semiconducting electrolyte guarantees high stability of the electrical properties over long periods of time and over a wide range of temperatures and frequencies.

FEATURE AND APPLICATION

● Feature

The product is a standard type that has been most widely used among tantalum chip capacitors.

- Molded Case available in four case codes.
- Compatible with automatic pick and place equipment.
- Meets or Exceeds EIA standard 535BAAC.

● Application

- General electronic equipment
- Smoothing Circuit of DC-DC Converters & Output side of AC-DC Converters
- De-Coupling Circuit of High Speed Ics & MPUs
- Various Other High Frequency Circuit Applications

■ STRUCTURE

Tantalum Capacitor

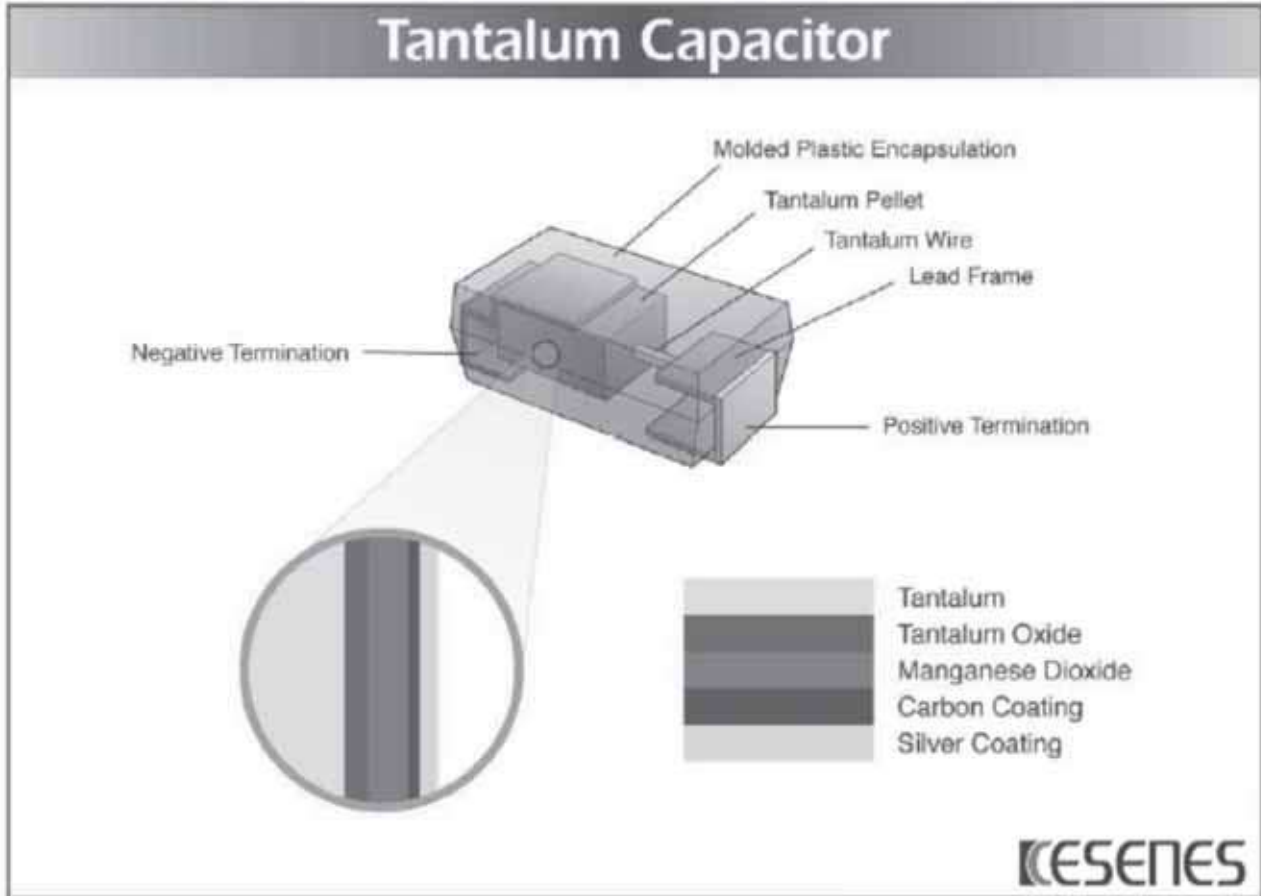

■ APPEARANCE AND DIMENSION

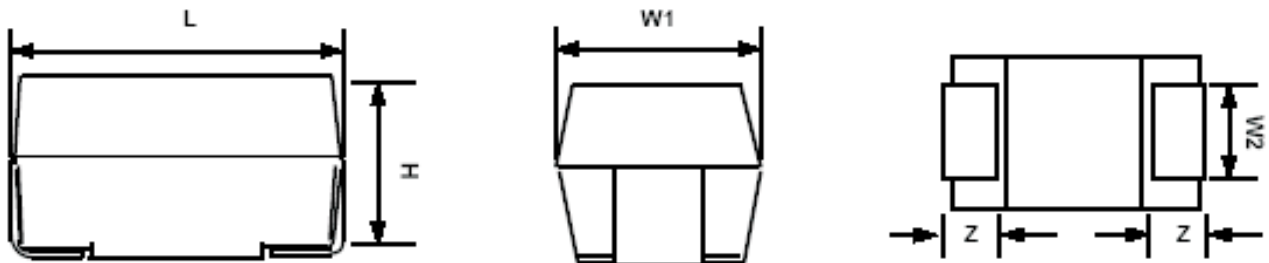

Case Code	EIA code	DIMENSION (mm)				
		L	W 1	W 2	H	Z
J	-	1.6 ± 0.1	0.8 ± 0.1	0.6 ± 0.1	0.8 ± 0.1	0.3 ± 0.15
P	2012	2.0 ± 0.2	1.25 ± 0.2	0.9 ± 0.1	1.1 ± 0.1	0.5 ± 0.1
A2	3216L	3.2 ± 0.2	1.6 ± 0.2	1.2 ± 0.1	1.1 ± 0.1	0.8 ± 0.2
A	3216	3.2 ± 0.2	1.6 ± 0.2	1.2 ± 0.1	1.6 ± 0.2	0.8 ± 0.2
B2	3528L	3.5 ± 0.2	2.8 ± 0.2	2.2 ± 0.1	1.1 ± 0.1	0.8 ± 0.2
B	3528	3.5 ± 0.2	2.8 ± 0.2	2.2 ± 0.1	1.9 ± 0.2	0.8 ± 0.2
C2	-	6.0 ± 0.2	3.2 ± 0.2	2.2 ± 0.1	1.4 ± 0.1	1.3 ± 0.2
C	6032	6.0 ± 0.2	3.2 ± 0.2	2.2 ± 0.1	2.5 ± 0.2	1.3 ± 0.2
D	7343	7.3 ± 0.2	4.3 ± 0.2	2.4 ± 0.1	2.8 ± 0.2	1.3 ± 0.2
E	7343H	7.3 ± 0.2	4.3 ± 0.2	2.4 ± 0.1	4.1 ± 0.2	1.3 ± 0.2
V	7361	7.3 ± 0.2	6.1 ± 0.2	3.1 ± 0.1	3.45 ± 0.3	1.4 ± 0.2

PART NUMBERING

● Product symbol

CA45
①C
②106
③M
④1C
⑤A
⑥

① Type ()

KESENES Tantalum Capacitor Normal - Standard series

② Dimension ()

Case Code	J	P	A	B	C	D	E	V
EIA Code	—	2012	3216	3528	6032	7343	7343H	7361

③ Capacitance ()

The first two digits are significant, The last digit specifies the number of zeros to follow; Third code indicate the power unit. (

Symbol	105	685	106	476	107	477
Capacitance (F)	1.0	6.8	10	47	100	470
Pico Farad (pF)	10x10 ⁵	68x10 ⁵	10x10 ⁶	47x10 ⁶	10x10 ⁷	47x10 ⁷

④ Tolerance ()

Symbol	J	K	M
Tolerance (%)	±5	±10	±20

⑤ Rated Voltage (额定电压)

Symbol	0E	0G	0J	1A	1C	1D	1E	1V	1T
DC Rated Voltage (V)	2.5	4	6.3	10	16	20	25	35	50

⑥ Packing

T: Bulk 500pcs/B ;

A: Tape Reel ,

J: 4000pcs/Reel ;

P: 3000pcs/Reel ;

A,B: 2000pcs/Reel ;

C,D,E,V: 500pcs/Reel .

MARKING ()

J Case



DC Working Voltage and Capacitance
Polarity (White)

P Case



DC Working Voltage and Capacitance
Polarity (White)

A Case

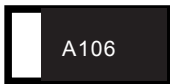

Capacitance Code
DC Working Voltage
Polarity (White)

A Case

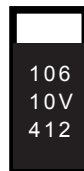

Polarity (White)
Capacitance Code
DC Working Voltage & KESENES I.D. Symbol
1st Digit = Year
2nd & 3rd Digits = Week
"412" = The 12nd week of 2004

B Case



Capacitance in μ F
DC Working Voltage
Polarity (White)

B Case

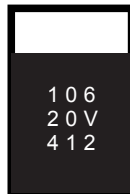

Polarity (White)
Capacitance Code
DC Working Voltage & KESENES I.D. Symbol
1st Digit = Year
2nd & 3rd Digits = Week
"412" = The 12nd week of 2004

C, D, E, V Case

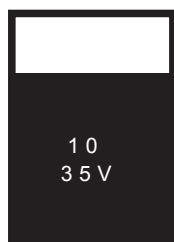

Polarity (White)
Capacitance in μ F
DC Working Voltage

C, D, E, V Case

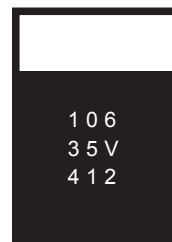

Polarity (White)
Capacitance Code
DC Working Voltage & KESENES I.D. Symbol
1st Digit = Year
2nd & 3rd Digits = Week
"412" = The 12nd week of 2004

STANDARD VALUE AND CASE SIZE (

μF \ U _R	2.5V (0E)	4V (0G)	6.3V (0J)	10V (1A)	16V (1C)	20V (1D)	25V (1E)	35V (1V)	50V (1T)
0.10								A	A
0.15								A	A,B
0.22								A	A,B
0.33							A	A	A,B
0.47					P	A2	A	A,B	A,B,C
0.68					P	A2,A	A	A,B	B,C
1.0			P	P	J,P,A	P,A2,A	P,A2,A,B	A2,A,B	B,C
1.5			P	J,P,A	J,A	A2,A	A,B	A,B,C	B,C,D
2.2		P	J,P,A	J,P,A,B	P,A2,A,B	P,A2,A,B	A,B,C	A,B,C	C,D
3.3		P,A	J,P,A	J,P,A2,A	P,A2,A,B	A2,A,B2,B	A,B,C	B2,B,C	C,D
4.7		P,A	J,P,A2,A,B	J,P,A2,A,B	A2,A,B2,B	A2,A,B2,B,C	A,B2,B,C	B,C,D	D
6.8		J,P,A2,A	J,P,A2,A,B	P,A2,A,B2,B	A,B2,B,C	A,B2,B,C2,C	B,C	C,D	D,E
10	J	J,P,A2,A,B	J,P,A2,A,B2,B,C	P,A2,A,B2,B,C	A,B2,B,C2,C	B,C2,C	B,C2,C,D	C,D,E	D,E
15	J	P,A2,A,B2,B	P,A2,A,B2,B,C	A2,A,B2,B,C2,C	A,B,C2,C	B,C,D	C,D	C,D,E	E
22	P,A2	P,A2,A,B2,B,C	P,A2,A,B2,B,C2,C	A,B2,B,C2,C	B2,B,C2,C,D	B,C2,C,D	C,D	D,E	V
33	P,A2,A	P,A2,A,B2,B,C2,C	A2,A,B2,B,C2,C	A,B2,B,C2,C,D	B,C2,C,D	C,D	D,E	D,E,V	
47	P,A2,A	P,A2,A,B2,B,C2,C	A,B2,B,C2,C,D	B,C2,C,D	C,D	C,D,E	D,E	E,V	
68	A	A,B2,B,C2,C,D	A,B2,B,C2,C,D	B,C2,C,D	C,D	D,E	E,V	V	
100	B2,B	A,B2,B,C2,C,D	B2,B,C2,C,D	B,C2,C,D,E	D,E	D,E,V	V		
150	A,B2,B,C2	B,C2,C,D	C,D,E	C,D,E	D,E,V	E,V			
220	B2,B,C2,D	B,C,D,E	C,D,E	D,E	D,E,V				
330	B,C,D	C,D,E	C,D,E,V	D,E,V	E,V				
470	B,C,D	D,E	D,E,V	E,V					
680	D,E	D,E	E,V	V					
1000	D,E	D,E,V	V						
1500	D,E,V								
2200	V								

STANDARD RATINGS ()

Rating (V)	Part Number	Capacitance (μ F)	Case Code	Max. DC Leakage @ + 25 °C (μ A)	DF (%) Max.	ESR (Ω) Max.
2.5	CA45J106*0EA	10	J	0.5	20	6.5
	CA45J156*0EA	15	J	0.5	20	8
	CA45P226*0EA	22	P	0.5	20	4
	CA45A2226*0EA	22	A2	0.5	12	3
	CA45P336*0EA	33	P	0.8	20	4
	CA45A2336*0EA	33	A2	0.8	12	4
	CA45A336*0EA	33	A	1.0	6	4
	CA45P476*0EA	47	P	1.1	30	6
	CA45A2476*0EA	47	A2	1.1	12	4.5
	CA45A476*0EA	47	A	1.1	12	4.5
	CA45A686*0EA	68	A	1.7	18	4.5
	CA45B2107*0EA	100	B2	2.5	18	1.3
	CA45B107*0EA	100	B	2.5	8	1
	CA45A157*0EA	150	A	3.7	30	2
	CA45B2157*0EA	150	B2	3.7	20	1
	CA45B157*0EA	150	B	3.0	10	1.6
	CA45C2157*0EA	150	C2	3.7	12	0.8
	CA45B2227*0EA	220	B2	5.5	30	1
	CA45B227*0EA	220	B	5.5	18	0.6
	CA45C2227*0EA	220	C2	5.5	12	0.8
	CA45D227*0EA	220	D	5.5	8	0.3
	CA45B337*0EA	330	B	8.2	25	0.6
	CA45C337*0EA	330	C	8.2	16	0.3
	CA45D337*0EA	330	D	8.2	8	0.3
	CA45B477*0EA	470	B	11.7	35	0.6
	CA45C447*0EA	470	C	11.7	18	1.5
	CA45D477*0EA	470	D	11.7	14	0.5
	CA45D687*0EA	680	D	17.0	16	0.2
	CA45E687*0EA	680	E	17.0	10	0.2
	CA45D108*0EA	1000	D	25.0	20	0.2
CA45E108*0EA	1000	E	20.0	14	0.4	
CA45D158*0EA	1500	D	37.5	60	0.2	
CA45E158*0EA	1500	E	37.0	20	0.2	
CA45V158*0EA	1500	V	30.0	20	0.2	
CA45V228*0EA	2200	V	55.0	50	0.2	
4	CA45P225*0GA	2.2	P	0.5	8	12
	CA45P335*0GA	3.3	P	0.5	20	20
	CA45A335*0GA	3.3	A	0.5	6	7.6
	CA45P475*0GA	4.7	P	0.5	8	6
	CA45A475*0GA	4.7	A	0.5	6	6.3
	CA45J685*0GA	6.8	J	0.5	20	7.5
	CA45P685*0GA	6.8	P	0.5	10	6
	CA45A2685*0GA	6.8	A2	0.5	6	15
	CA45A685*0GA	6.8	A	0.5	6	5.5
	CA45J106*0GA	10	J	0.5	20	6.5
	CA45P106*0GA	10	P	0.5	20	6

* To complete KESENES Part Number, insert M for $\pm 20\%$ tolerance or K for $\pm 10\%$ tolerance.

Rating (V)	Part Number	Capacitance (μ F)	Case Code	Max. DC Leakage @ + 25 °C (μ A)	DF (%) Max.	ESR (Ω) Max.
4	CA45A2106*0GA	10	A2	0.5	6	15
	CA45A106*0GA	10	A	0.5	6	5.1
	CA45B106*0GA	10	B	0.5	6	3.5
	CA45P156*0GA	15	P	0.6	20	5
	CA45A2156*0GA	15	A2	0.6	10	15
	CA45A156*0GA	15	A	0.6	6	3.4
	CA45B2156*0GA	15	B2	0.6	6	5
	CA45B156*0GA	15	B	0.6	6	2.9
	CA45P226*0GA	22	P	0.8	20	4
	CA45A2226*0GA	22	A2	0.8	12	2.8
	CA45A226*0GA	22	A	0.8	8	2.5
	CA45B2226*0GA	22	B2	0.9	6	5
	CA45B226*0GA	22	B	0.9	6	2.5
	CA45C226*0GA	22	C	0.9	6	1.8
	CA45P336*0GA	33	P	1.3	20	4
	CA45A2336*0GA	33	A2	1.3	8	4.5
	CA45A336*0GA	33	A	1.3	10	3
	CA45B2336*0GA	33	B2	1.3	8	5
	CA45B336*0GA	33	B	1.3	6	2
	CA45C2336*0GA	33	C2	1.3	6	1.8
	CA45C336*0GA	33	C	1.3	6	1.8
	CA45P476*0GA	47	P	1.8	30	3
	CA45A2476*0GA	47	A2	1.8	15	4.5
	CA45A476*0GA	47	A	1.8	12	2.5
	CA45B2476*0GA	47	B2	1.8	12	1.7
	CA45B476*0GA	47	B	1.9	6	1.9
	CA45C2476*0GA	47	C2	1.9	6	1.8
	CA45C476*0GA	47	C	1.9	6	1.8
	CA45A686*0GA	68	A	2.7	12	2.5
	CA45B2686*0GA	68	B2	2.7	15	1.5
	CA45B686*0GA	68	B	2.7	6	1.9
	CA45C2686*0GA	68	C2	2.7	6	1.8
	CA45C686*0GA	68	C	2.7	6	1.4
	CA45D686*0GA	68	D	2.7	6	0.8
	CA45A107*0GA	100	A	4.0	30	2
	CA45B2107*0GA	100	B2	4.0	20	1.3
	CA45B107*0GA	100	B	4.0	12	0.8
	CA45C2107*0GA	100	C2	4.0	10	0.8
	CA45C107*0GA	100	C	4.0	6	0.8
	CA45D107*0GA	100	D	4.0	6	0.7
	CA45B157*0GA	150	B	6.0	18	0.7
	CA45C2157*0GA	150	C2	6.0	10	0.8
CA45C157*0GA	150	C	6.0	12	0.7	
CA45D157*0GA	150	D	6.0	8	0.6	
CA45B227*0GA	220	B	8.8	18	0.5	
CA45C227*0GA	220	C	8.8	12	0.6	

* To complete KESENES Part Number, insert M for $\pm 20\%$ tolerance or K for $\pm 10\%$ tolerance.

Rating (V)	Part Number	Capacitance (μ F)	Case Code	Max. DC Leakage @ + 25 °C (μ A)	DF (%) Max.	ESR (Ω) Max.
4	CA45D227*0GA	220	D	8.8	8	0.6
	CA45E227*0GA	220	E	8.8	8	0.5
	CA45C337*0GA	330	C	13.2	14	0.2
	CA45D337*0GA	330	D	13.2	8	0.6
	CA45E337*0GA	330	E	13.2	8	0.5
	CA45D477*0GA	470	D	18.8	16	0.3
	CA45E477*0GA	470	E	18.8	10	0.5
	CA45D687*0GA	680	D	27.2	24	0.3
	CA45E687*0GA	680	E	27.2	12	0.5
	CA45D108*0GA	1000	D	40.0	60	0.2
	CA45E108*0GA	1000	E	40.0	12	0.5
	CA45V108*0GA	1000	V	40	15	0.2
6.3	CA45P105*0JA	1.0	P	0.5	8	12
	CA45P155*0JA	1.5	P	0.5	10	25
	CA45J225*0JA	2.2	J	0.5	20	17.5
	CA45P225*0JA	2.2	P	0.5	8	12
	CA45A225*0JA	2.2	A	0.5	6	7.6
	CA45J335*0JA	3.3	J	0.5	20	13.5
	CA45P335*0JA	3.3	P	0.5	8	12
	CA45A335*0JA	3.3	A	0.5	6	6.3
	CA45J475*0JA	4.7	J	0.5	20	8.5
	CA45P475*0JA	4.7	P	0.5	20	10
	CA45A2475*0JA	4.7	A2	0.5	6	15
	CA45A475*0JA	4.7	A	0.5	8	5.5
	CA45B475*0JA	4.7	B	0.5	6	5
	CA45J685*0JA	6.8	J	0.5	20	7
	CA45P685*0JA	6.8	P	0.5	20	7
	CA45A2685*0JA	6.8	A2	0.5	8	6.5
	CA45A685*0JA	6.8	A	0.5	6	5
	CA45B685*0JA	6.8	B	0.5	6	3.4
	CA45J106*0JA	10	J	0.6	20	8
	CA45P106*0JA	10	P	0.6	20	6
	CA45A2106*0JA	10	A2	0.6	8	4.5
	CA45A106*0JA	10	A	0.6	8	3.2
	CA45B2106*0JA	10	B2	0.6	6	5
	CA45B106*0JA	10	B	0.6	6	2.9
	CA45C106*0JA	10	C	0.6	6	2.5
	CA45P156*0JA	15	P	0.9	20	5
	CA45A2156*0JA	15	A2	0.9	12	4
	CA45A156*0JA	15	A	0.9	8	3
	CA45B2156*0JA	15	B2	0.9	6	5
	CA45B156*0JA	15	B	0.9	6	2.5
	CA45C156*0JA	15	C	0.9	6	1.8
	CA45P226*0JA	22	P	1.3	20	4
	CA45A2226*0JA	22	A2	1.3	12	2.8
CA45A226*0JA	22	A	1.3	10	3	

* To complete KESENES Part Number, insert M for $\pm 20\%$ tolerance or K for $\pm 10\%$ tolerance.

Rating (V)	Part Number	Capacitance (μ F)	Case Code	Max. DC Leakage @ + 25 °C (μ A)	DF (%) Max.	ESR (Ω) Max.
6.3	CA45B2226*0JA	22	B2	1.3	8	2
	CA45B226*0JA	22	B	1.3	8	1.6
	CA45C2226*0JA	22	C2	1.4	6	1.8
	CA45C226*0JA	22	C	1.3	6	1.8
	CA45A2336*0JA	33	A2	2.0	18	3
	CA45A336*0JA	33	A	2.0	12	2.5
	CA45B2336*0JA	33	B2	2.0	12	1.7
	CA45B336*0JA	33	B	2.0	6	1.9
	CA45C2336*0JA	33	C2	2.0	6	1.8
	CA45C336*0JA	33	C	2.0	6	1.5
	CA45A476*0JA	47	A	2.9	12	2
	CA45B2476*0JA	47	B2	2.9	12	1.7
	CA45B476*0JA	47	B	2.9	8	1.3
	CA45C2476*0JA	47	C2	2.9	6	1.8
	CA45C476*0JA	47	C	2.9	8	0.9
	CA45D476*0JA	47	D	2.8	6	0.8
	CA45A686*0JA	68	A	4.2	30	2
	CA45B2686*0JA	68	B2	4.2	20	2
	CA45B686*0JA	68	B	4.2	10	1
	CA45C2686*0JA	68	C2	4.2	10	0.8
	CA45C686*0JA	68	C	4.1	6	0.8
	CA45D686*0JA	68	D	4.1	6	0.7
	CA45B2107*0JA	100	B2	6.3	20	1.3
	CA45B107*0JA	100	B	6.3	12	0.9
	CA45C2107*0JA	100	C2	6.3	10	0.8
	CA45C107*0JA	100	C	6.3	10	0.6
	CA45D107*0JA	100	D	6.0	6	0.7
	CA45C157*0JA	150	C	9.4	10	0.6
	CA45D157*0JA	150	D	9.0	8	0.6
	CA45E157*0JA	150	E	9.0	8	0.5
	CA45C227*0JA	220	C	13.8	14	1.2
	CA45D227*0JA	220	D	13.8	12	0.5
	CA45E227*0JA	220	E	13.2	8	0.5
	CA45C337*0JA	330	C	20.7	14	0.6
	CA45D337*0JA	330	D	20.7	14	0.5
	CA45E337*0JA	330	E	19.8	8	0.5
	CA45V337*0JA	330	V	20.8	8	0.5
	CA45D477*0JA	470	D	29.6	20	0.3
	CA45E477*0JA	470	E	28.2	10	0.5
	CA45V477*0JA	470	V	29.6	10	0.4
CA45E687*0JA	680	E	42.8	10	0.5	
CA45V687*0JA	680	V	40.8	12	0.5	
CA45V108*0JA	1000	V	63.0	16	0.4	
10	CA45P105*1AA	1.0	P	0.5	10	25
	CA45J155*1AA	1.5	J	0.5	20	25.5
	CA45P155*1AA	1.5	P	0.5	20	25

* To complete KESENES Part Number, insert M for $\pm 20\%$ tolerance or K for $\pm 10\%$ tolerance.

Rating (V)	Part Number	Capacitance (μ F)	Case Code	Max. DC Leakage @ + 25 °C (μ A)	DF (%) Max.	ESR (Ω) Max.
10	CA45A155*1AA	1.5	A	0.5	6	8
	CA45J225*1AA	2.2	J	0.5	20	17.5
	CA45P225*1AA	2.2	P	0.5	20	19
	CA45A225*1AA	2.2	A	0.5	6	6.3
	CA45B225*1AA	2.2	B	0.5	6	3.5
	CA45J335*1AA	3.3	J	0.5	20	25
	CA45P335*1AA	3.3	P	0.5	20	13
	CA45A2335*1AA	3.3	A2	0.5	8	8
	CA45A335*1AA	3.3	A	0.5	6	5.5
	CA45J475*1AA	4.7	J	0.5	20	10
	CA45P475*1AA	4.7	P	0.5	20	6
	CA45A2475*1AA	4.7	A2	0.5	8	8
	CA45A475*1AA	4.7	A	0.5	8	4.5
	CA45B475*1AA	4.7	B	0.5	6	3.4
	CA45P685*1AA	6.8	P	0.5	8	6
	CA45A2685*1AA	6.8	A2	0.6	8	8
	CA45A685*1AA	6.8	A	0.6	8	4.5
	CA45B2685*1AA	6.8	B2	0.7	6	5
	CA45B685*1AA	6.8	B	0.7	6	2.9
	CA45P106*1AA	10	P	1.0	20	6
	CA45A2106*1AA	10	A2	1.0	8	8
	CA45A106*1AA	10	A	1.0	8	3.2
	CA45B2106*1AA	10	B2	1.0	6	5
	CA45B106*1AA	10	B	1.0	8	2.4
	CA45C106*1AA	10	C	1.0	6	1.8
	CA45A2156*1AA	15	A2	1.5	12	3
	CA45A156*1AA	15	A	1.5	6	2.9
	CA45B2156*1AA	15	B2	1.5	8	2.7
	CA45B156*1AA	15	B	1.5	6	2
	CA45C2156*1AA	15	C2	1.5	6	1.8
	CA45C156*1AA	15	C	1.5	6	1.8
	CA45A226*1AA	22	A	2.2	12	2.5
	CA45B2226*1AA	22	B2	2.2	8	1.9
	CA45B226*1AA	22	B	2.2	8	1.4
	CA45C2226*1AA	22	C2	2.2	6	1.8
	CA45C226*1AA	22	C	2.2	6	1.5
	CA45A336*1AA	33	A	3.3	8	1.7
	CA45B2336*1AA	33	B2	3.3	12	1.7
	CA45B336*1AA	33	B	3.3	8	1.4
	CA45C2336*1AA	33	C2	3.3	6	1.8
	CA45C336*1AA	33	C	3.3	6	1.4
	CA45D336*1AA	33	D	3.3	6	0.8
	CA45B476*1AA	47	B	4.7	8	1
	CA45C2476*1AA	47	C2	4.7	8	1
CA45C476*1AA	47	C	4.7	8	0.9	
CA45D476*1AA	47	D	4.7	6	0.7	

* To complete KESENES Part Number, insert M for $\pm 20\%$ tolerance or K for $\pm 10\%$ tolerance.

Rating (V)	Part Number	Capacitance (μ F)	Case Code	Max. DC Leakage @ + 25 °C (μ A)	DF (%) Max.	ESR (Ω) Max.
10	CA45B686*1AA	68	B	6.8	12	0.9
	CA45C2686*1AA	68	C2	6.8	10	1
	CA45C686*1AA	68	C	6.8	8	0.7
	CA45D686*1AA	68	D	6.8	6	0.7
	CA45B107*1AA	100	B	10.0	8	1.4
	CA45C2107*1AA	100	C2	10.0	10	0.8
	CA45C107*1AA	100	C	10.0	10	0.5
	CA45D107*1AA	100	D	10.0	8	0.6
	CA45E107*1AA	100	E	10.0	8	0.5
	CA45C157*1AA	150	C	15.0	8	0.9
	CA45D157*1AA	150	D	15.0	10	0.6
	CA45E157*1AA	150	E	15.0	8	0.5
	CA45D227*1AA	220	D	22.0	12	0.6
	CA45E227*1AA	220	E	22.0	8	0.5
	CA45D337*1AA	330	D	33.0	8	0.9
	CA45E337*1AA	330	E	33.0	10	0.5
	CA45V337*1AA	330	V	33.0	10	0.5
	CA45E477*1AA	470	E	47.0	10	0.2
	CA45V447*1AA	470	V	47.0	12	0.5
	CA45V687*1AA	680	V	68.0	12	0.9
16	CA45P474*1CA	0.47	P	0.5	10	35
	CA45P684*1CA	0.68	P	0.5	10	25
	CA45J105*1CA	1.0	J	0.5	10	25.5
	CA45P105*1CA	1.0	P	0.5	10	20
	CA45A105*1CA	1.0	A	0.5	4	9.3
	CA45J155*1CA	1.5	J	0.5	10	25
	CA45A155*1CA	1.5	A	0.5	4	6
	CA45P225*1CA	2.2	P	0.5	10	19
	CA45A225*1CA	2.2	A2	0.5	6	10
	CA45A225*1CA	2.2	A	0.5	6	6
	CA45B225*1CA	2.2	B	0.5	6	4.6
	CA45P335*1CA	3.3	P	0.5	10	8
	CA45A2335*1CA	3.3	A2	0.5	8	7
	CA45A335*1CA	3.3	A	0.5	6	4.5
	CA45B335*1CA	3.3	B	0.5	6	3.5
	CA45A2475*1CA	4.7	A2	0.7	8	4.5
	CA45A475*1CA	4.7	A	0.7	6	4
	CA45B2475*1CA	4.7	B2	0.8	6	5
	CA45B475*1CA	4.7	B	0.8	6	2.9
	CA45A685*1CA	6.8	A	1.0	6	4
	CA45B2685*1CA	6.8	B2	1.0	6	4.1
	CA45B685*1CA	6.8	B	1.1	6	2.5
	CA45C685*1CA	6.8	C	1.1	6	1.9
	CA45A106*1CA	10	A	1.6	8	3.2
	CA45B2106*1CA	10	B2	1.6	8	3.5
	CA45B106*1CA	10	B	1.6	6	2

* To complete KESENES Part Number, insert M for $\pm 20\%$ tolerance or K for $\pm 10\%$ tolerance.

Rating (V)	Part Number	Capacitance (μ F)	Case Code	Max. DC Leakage @ + 25 °C (μ A)	DF (%) Max.	ESR (Ω) Max.
16	CA45C2106*1CA	10	C2	1.6	6	1.8
	CA45C106*1CA	10	C	1.6	6	1.8
	CA45A156*1CA	15	A	2.4	12	5
	CA45B156*1CA	15	B	2.4	6	2
	CA45C2156*1CA	15	C2	2.4	6	1.8
	CA45C156*1CA	15	C	2.4	6	1.5
	CA45B2226*1CA	22	B2	3.5	10	2.2
	CA45B226*1CA	22	B	3.5	6	2.2
	CA45C2226*1CA	22	C2	3.6	10	3
	CA45C226*1CA	22	C	3.5	6	1.5
	CA45D226*1CA	22	D	3.5	6	0.8
	CA45B336*1CA	33	B	5.2	8	1.4
	CA45C2336*1CA	33	C2	5.2	6	1.4
	CA45C336*1CA	33	C	5.2	6	1.1
	CA45D336*1CA	33	D	5.3	6	0.7
	CA45C476*1CA	47	C	7.5	6	0.8
	CA45D476*1CA	47	D	7.5	6	0.7
	CA45C686*1CA	68	C	10.8	6	0.7
	CA45D686*1CA	68	D	10.8	6	0.7
	CA45D107*1CA	100	D	16.0	8	0.5
	CA45E107*1CA	100	E	16.0	8	0.6
	CA45D157*1CA	150	D	24.0	12	0.7
	CA45E157*1CA	150	E	24.0	8	0.5
	CA45V157*1CA	150	V	24.0	8	0.5
	CA45D227*1CA	220	D	35.2	12	0.5
	CA45E227*1CA	220	E	35.2	10	0.5
	CA45V227*1CA	220	V	35.2	7.2	0.9
	CA45E337*1CA	330	E	40.0	12	0.9
	CA45V337*1CA	330	V	40.0	12	0.7
	20	CA45A2474*1DA	0.47	A2	0.5	6
CA45A2684*1DA		0.68	A2	0.5	6	15
CA45A684*1DA		0.68	A	0.5	4	10
CA45P105*1DA		1.0	P	0.5	6	20
CA45A2105*1DA		1.0	A2	0.5	6	12
CA45A105*1DA		1.0	A	0.5	4	8.4
CA45A2155*1DA		1.5	A2	0.5	6	7.4
CA45A155*1DA		1.5	A	0.5	6	6.3
CA45P225*1DA		2.2	P	0.5	10	8
CA45A2225*1DA		2.2	A2	0.5	6	7
CA45A225*1DA		2.2	A	0.5	6	6
CA45B225*1DA		2.2	B	0.5	6	3.5
CA45A2335*1DA		3.3	A2	0.6	8	5
CA45A335*1DA		3.3	A	0.6	6	5
CA45B2335*1DA		3.3	B2	0.6	6	3.9
CA45B335*1DA		3.3	B	0.7	6	3
CA45A2475*1DA		4.7	A2	0.9	15	5

* To complete KESENES Part Number, insert M for $\pm 20\%$ tolerance or K for $\pm 10\%$ tolerance.

Rating (V)	Part Number	Capacitance (μ F)	Case Code	Max. DC Leakage @ + 25 °C (μ A)	DF (%) Max.	ESR (Ω) Max.
20	CA45A475*1DA	4.7	A	0.9	6	5
	CA45B2475*1DA	4.7	B2	0.9	6	3
	CA45B475*1DA	4.7	B	0.9	6	3
	CA45C475*1DA	4.7	C	0.9	6	2.3
	CA45A685*1DA	6.8	A	1.4	6	4.5
	CA45B2685*1DA	6.8	B2	1.3	6	3
	CA45B685*1DA	6.8	B	1.3	6	2.8
	CA45C2685*1DA	6.8	C2	1.4	6	1.9
	CA45C685*1DA	6.8	C	1.4	6	1.9
	CA45B106*1DA	10	B	2.0	6	2.5
	CA45C2106*1DA	10	C2	2.0	6	1.8
	CA45C106*1DA	10	C	2.0	6	1.7
	CA45B156*1DA	15	B	3.0	6	2.3
	CA45C156*1DA	15	C	3.0	6	1.7
	CA45D156*1DA	15	D	3.0	6	0.9
	CA45B226*1DA	22	B	4.4	6	2.1
	CA45C226*1DA	22	C2	4.4	6	1.4
	CA45C226*1DA	22	C	4.4	6	1.4
	CA45D226*1DA	22	D	4.4	6	0.8
	CA45C336*1DA	33	C	6.6	6	1
	CA45D336*1DA	33	D	6.6	6	0.8
	CA45C476*1DA	47	C	9.4	6	0.9
	CA45D476*1DA	47	D	9.4	6	0.7
	CA45E476*1DA	47	E	9.4	6	0.6
	CA45D686*1DA	68	D	13.6	6	0.7
	CA45E686*1DA	68	E	13.6	6	0.6
	CA45D107*1DA	100	D	20.0	6	0.9
	CA45E107*1DA	100	E	20.0	8	0.5
CA45V107*1DA	100	V	20.0	8	0.5	
CA45E157*1DA	150	E	30.0	10	0.5	
CA45V157*1DA	150	V	30.0	8	0.5	
25	CA45A334*1EA	0.33	A	0.5	4	15
	CA45A474*1EA	0.47	A	0.5	4	13
	CA45A684*1EA	0.68	A	0.5	6	9
	CA45P105*1EA	1.0	P	0.5	6	8
	CA45A2105*1EA	1.0	A2	0.5	6	13
	CA45A105*1EA	1.0	A	0.5	6	8
	CA45B105*1EA	1.0	B	0.5	4	5
	CA45A155*1EA	1.5	A	0.5	6	6.7
	CA45B155*1EA	1.5	B	0.5	6	4.6
	CA45A225*1EA	2.2	A	0.5	6	7
	CA45B225*1EA	2.2	B	0.6	6	3.8
	CA45C225*1EA	2.2	C	0.6	6	3.5
	CA45A335*1EA	3.3	A	0.8	6	7
	CA45B335*1EA	3.3	B	0.8	6	3.1
	CA45C335*1EA	3.3	C	0.8	6	2.3

* To complete KESENES Part Number, insert M for $\pm 20\%$ tolerance or K for $\pm 10\%$ tolerance.

Rating (V)	Part Number	Capacitance (μ F)	Case Code	Max. DC Leakage @ + 25 °C (μ A)	DF (%) Max.	ESR (Ω) Max.
25	CA45A475*1EA	4.7	A	1.2	6	5.5
	CA45B2475*1EA	4.7	B2	1.1	6	3
	CA45B475*1EA	4.7	B	1.1	6	3
	CA45C475*1EA	4.7	C	1.2	6	2
	CA45B685*1EA	6.8	B	1.7	6	2.4
	CA45C685*1EA	6.8	C	1.7	6	1.7
	CA45B106*1EA	10	B	2.5	6	2.3
	CA45C2106*1EA	10	C2	2.5	6	2
	CA45C106*1EA	10	C	2.5	6	1.5
	CA45D106*1EA	10	D	2.5	6	1
	CA45C156*1EA	15	C	3.7	6	1.5
	CA45D156*1EA	15	D	3.8	6	0.8
	CA45C226*1EA	22	C	5.5	6	1.4
	CA45D226*1EA	22	D	5.5	6	0.8
	CA45D336*1EA	33	D	8.2	6	0.7
	CA45E336*1EA	33	E	8.3	6	0.6
	CA45D476*1EA	47	D	11.8	10	0.7
	CA45E476*1EA	47	E	11.8	6	0.6
	CA45E686*1EA	68	E	17.0	8	0.7
	CA45V686*1EA	68	V	17.0	6	0.9
CA45V107*1EA	100	V	25.0	8	0.4	
35	CA45A104*1VA	0.1	A	0.5	4	20
	CA45A154*1VA	0.15	A	0.5	4	18
	CA45A224*1VA	0.22	A	0.5	4	15
	CA45A334*1VA	0.33	A	0.5	4	13
	CA45A474*1VA	0.47	A	0.5	6	12
	CA45B474*1VA	0.47	B	0.5	4	8
	CA45A684*1VA	0.68	A	0.5	6	8
	CA45B684*1VA	0.68	B	0.5	4	6.5
	CA45A2105*1VA	1.0	A2	0.5	6	13
	CA45A105*1VA	1.0	A	0.5	6	7
	CA45B105*1VA	1.0	B	0.5	4	5
	CA45A155*1VA	1.5	A	0.5	6	7
	CA45B155*1VA	1.5	B	0.5	6	4.2
	CA45C155*1VA	1.5	C	0.5	6	3.8
	CA45A225*1VA	2.2	A	0.7	6	5
	CA45B225*1VA	2.2	B	0.7	6	4
	CA45C225*1VA	2.2	C	0.8	6	2.9
	CA45B2335*1VA	3.3	B2	1.1	6	3
	CA45B335*1VA	3.3	B	1.1	6	3.5
	CA45C335*1VA	3.3	C	1.2	6	2.1
	CA45B475*1VA	4.7	B	1.2	6	3.1
	CA45C475*1VA	4.7	C	1.6	6	2.2
	CA45D475*1VA	4.7	D	1.6	6	1.3
	CA45C685*1VA	6.8	C	2.3	6	1.9
	CA45D685*1VA	6.8	D	2.4	6	1.1

* To complete KESENES Part Number, insert M for $\pm 20\%$ tolerance or K for $\pm 10\%$ tolerance.

Rating (V)	Part Number	Capacitance (μ F)	Case Code	Max. DC Leakage @ + 25 °C (μ A)	DF (%) Max.	ESR (Ω) Max.
35	CA45C106*1VA	10	C	3.5	6	1.5
	CA45D106*1VA	10	D	3.5	6	1
	CA45E106*1VA	10	E	3.5	6	0.9
	CA45C156*1VA	15	C	5.3	6	1.4
	CA45D156*1VA	15	D	5.2	6	0.9
	CA45E156*1VA	15	E	5.3	6	0.7
	CA45D226*1VA	22	D	7.7	6	0.6
	CA45E226*1VA	22	E	7.7	6	0.6
	CA45D336*1VA	33	D	11.6	6	0.9
	CA45E336*1VA	33	E	11.6	6	0.6
	CA45V336*1VA	33	V	11.6	6	0.5
	CA45E476*1VA	47	E	16.5	8	0.6
	CA45V476*1VA	47	V	16.5	10	0.5
	CA45V686*1VA	68	V	23.8	6	0.5
50	CA45A104*1TA	0.1	A	0.5	4	19
	CA45A154*1TA	0.15	A	0.5	4	17
	CA45B154*1TA	0.15	B	0.5	4	14
	CA45A224*1TA	0.22	A	0.5	4	15
	CA45B224*1TA	0.22	B	0.5	4	12
	CA45A334*1TA	0.33	A	0.5	4	14
	CA45B334*1TA	0.33	B	0.5	4	10
	CA45A474*1TA	0.47	A	0.5	4	12
	CA45B474*1TA	0.47	B	0.5	4	8.4
	CA45C474*1TA	0.47	C	0.5	4	6.7
	CA45B684*1TA	0.68	B	0.5	4	7.6
	CA45C684*1TA	0.68	C	0.5	4	5.9
	CA45B105*1TA	1.0	B	0.5	4	6.7
	CA45C105*1TA	1.0	C	0.5	4	4.6
	CA45B155*1TA	1.5	B	0.8	6	6
	CA45C155*1TA	1.5	C	0.8	6	3.4
	CA45D155*1TA	1.5	D	0.8	6	3.5
	CA45C225*1TA	2.2	C	1.1	6	2.9
	CA45D225*1TA	2.2	D	1.1	6	2.1
	CA45C335*1TA	3.3	C	1.7	6	2.5
	CA45D335*1TA	3.3	D	1.7	6	1.7
	CA45D475*1TA	4.7	D	2.4	6	1.2
	CA45D685*1TA	6.8	D	3.4	6	0.9
	CA45E685*1TA	6.8	E	3.4	6	0.9
	CA45D106*1TA	10	D	5.0	6	0.8
	CA45E106*1TA	10	E	5.0	6	0.8
	CA45E156*1TA	15	E	7.5	8	0.7
	CA45V226*1TA	22	V	11	8	0.6

* To complete KESENES Part Number, insert M for $\pm 20\%$ tolerance or K for $\pm 10\%$ tolerance.

■ Characteristics

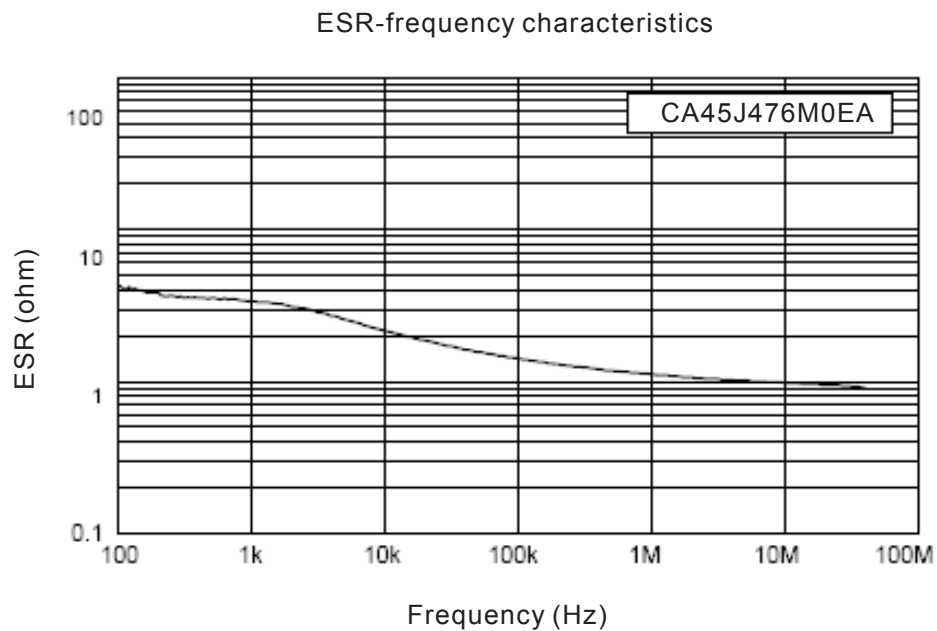
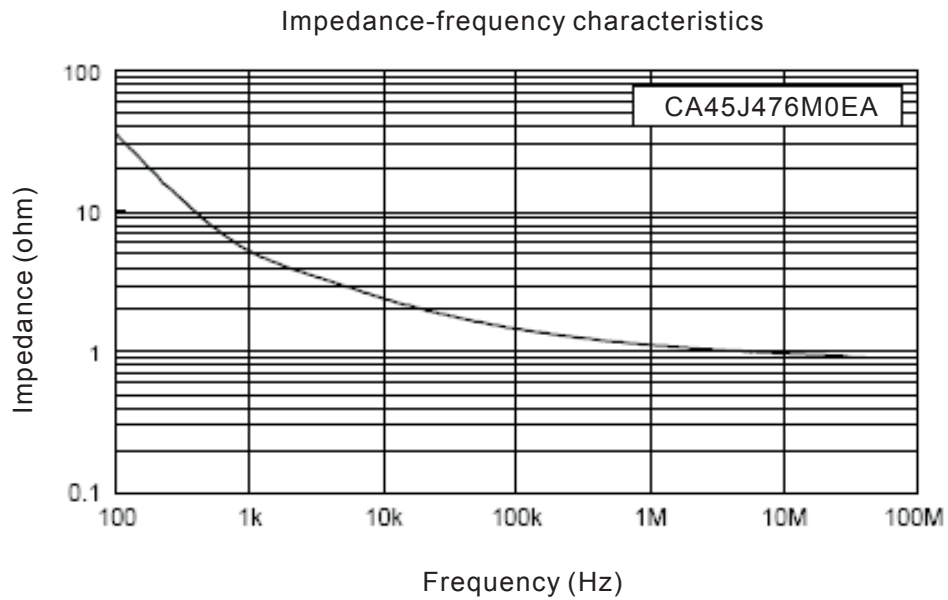

Impedance-frequency characteristics

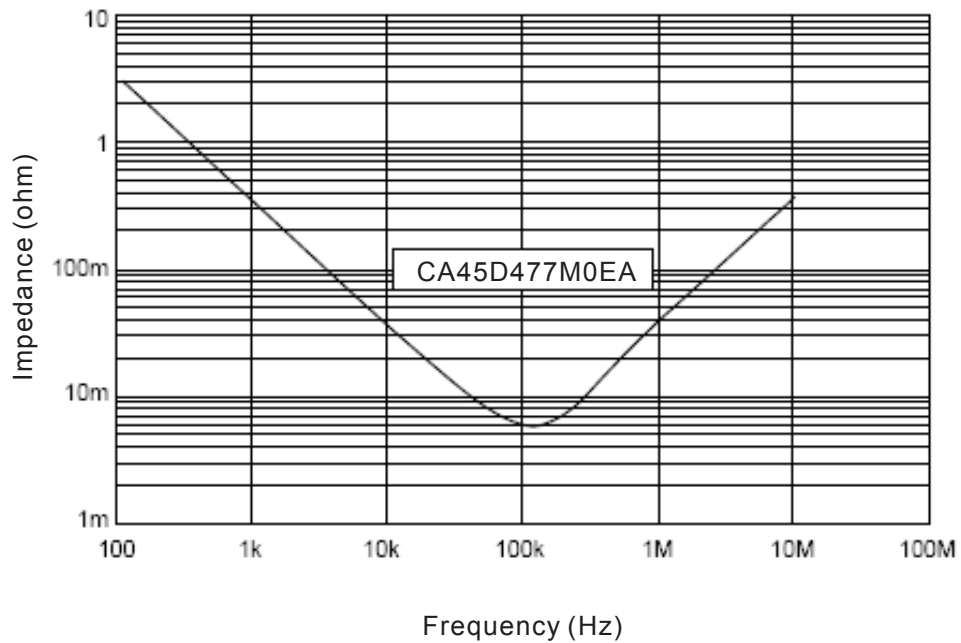

ESR-frequency characteristics

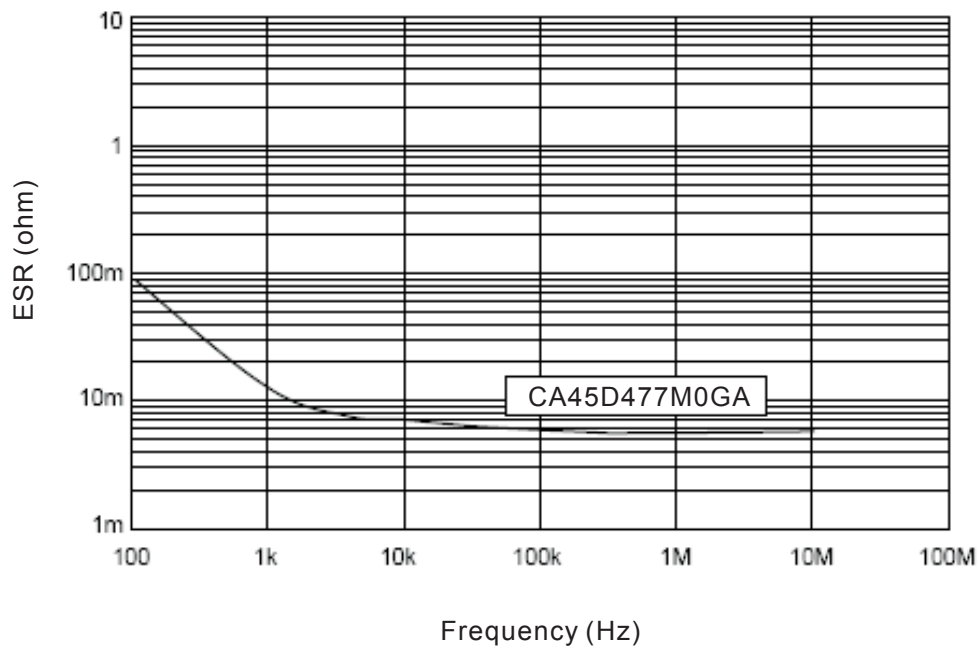

EMBOSSED PLASTIC TYPE

The tantalum chip capacitors shall be packaged in tape and reel form for effective use.

- Tape: Semitransparent embossed plastic
- Cover tape: Attached with press, polyester
- The tension of removing the cover tape, $F = 10 \sim 70g$

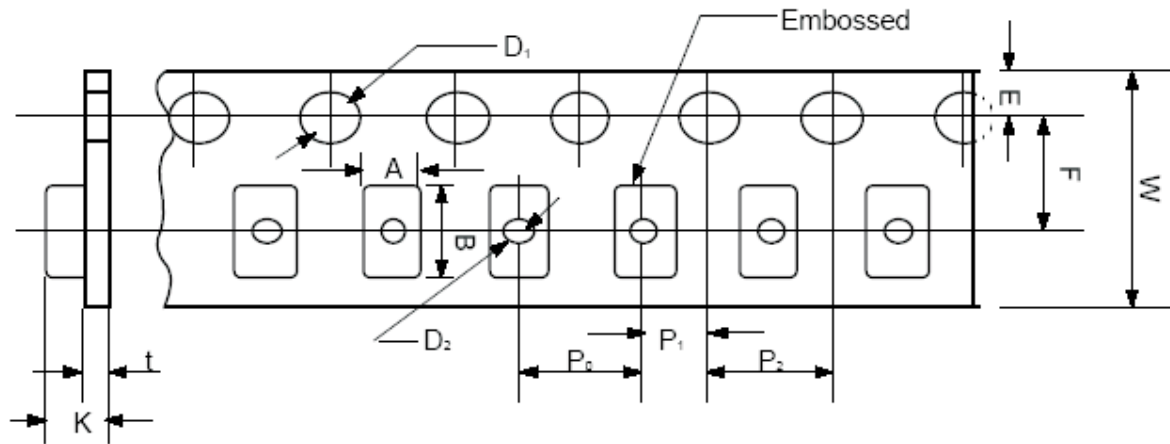
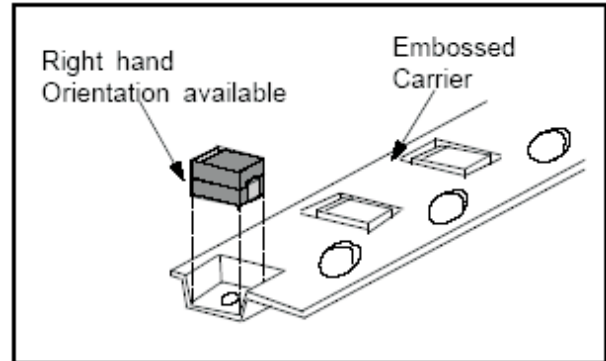

Case Code	$W \pm 0.3$	$F \pm 0.1$	$E \pm 0.1$	$P_0 \pm 0.1$	$P_1 \pm 0.1$	$P_2 \pm 0.1$	$D_1 \pm 0.1$	D_2 Min	t	$A \pm 0.2$	$B \pm 0.2$	$K \pm 0.2$
J	8	3.5	1.75	4	2	4	$\phi 1.5$	$\phi 1.0$	0.2	1.2	2.0	1.1
P										1.4	2.3	1.4
A										1.9	3.5	1.9
B	12	5.5	8						0.3	3.3	3.8	2.1
C										3.7	6.4	3.0
D										4.8	7.7	3.3
E										6.4		4.25
V											3.85	

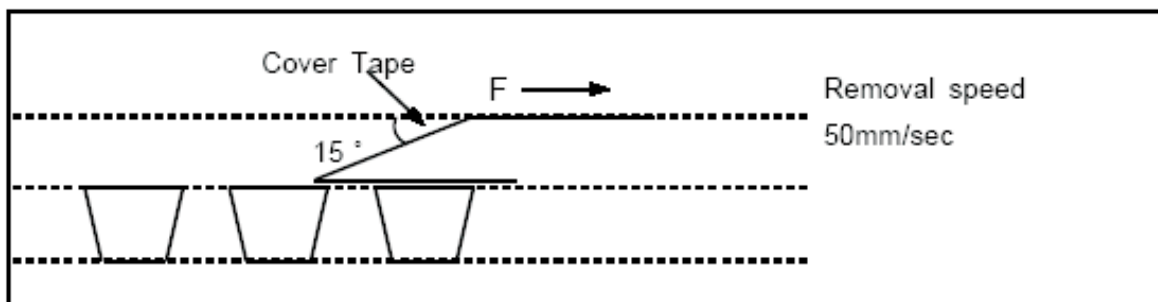

REEL DIMENSION ()

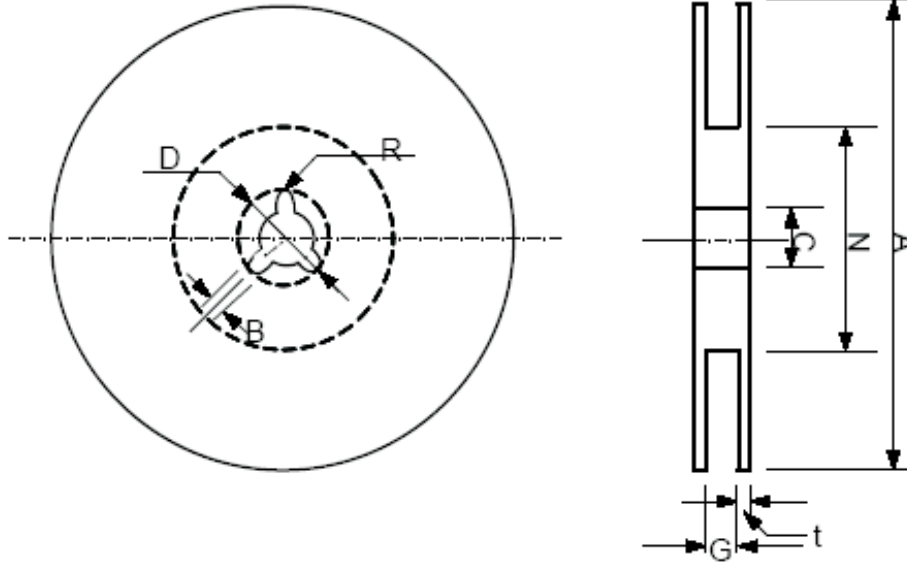

Tape Width	A ± 2	N Min.	C ± 0.5	D ± 0.5	B ± 0.51	G	t ± 0.5	R
8mm	φ 178	φ 50	φ 13	φ 21	2	10	2	0.99
12mm						14		