

# 100ZFS-xxA, 100ZFS-xxB

## FPC/FFC 1.0mm ZIF SMT Type Top Entry

### SPECIFICATION

Current Rate: 0.5 AMP  
 Insulation Resistance: 500M  $\Omega$  Min.  
 Contact Resistance: 30m  $\Omega$  Max.  
 Dielectric Voltage: 500V AC for one minute  
 Operation Temperature: -55°C to +85°C

### MATERIAL

Insulator: Polyester, UL 94V-0  
 Standard: Nylon 46  
 Contact Pin: Copper Alloy  
 Contact Plating: Tin Plated

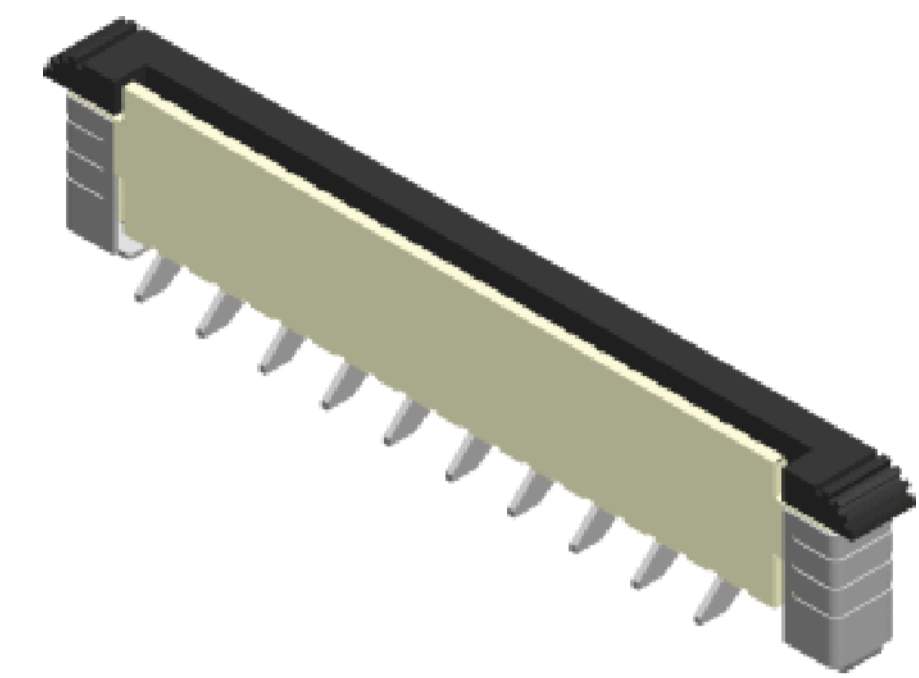

### TYPE 1

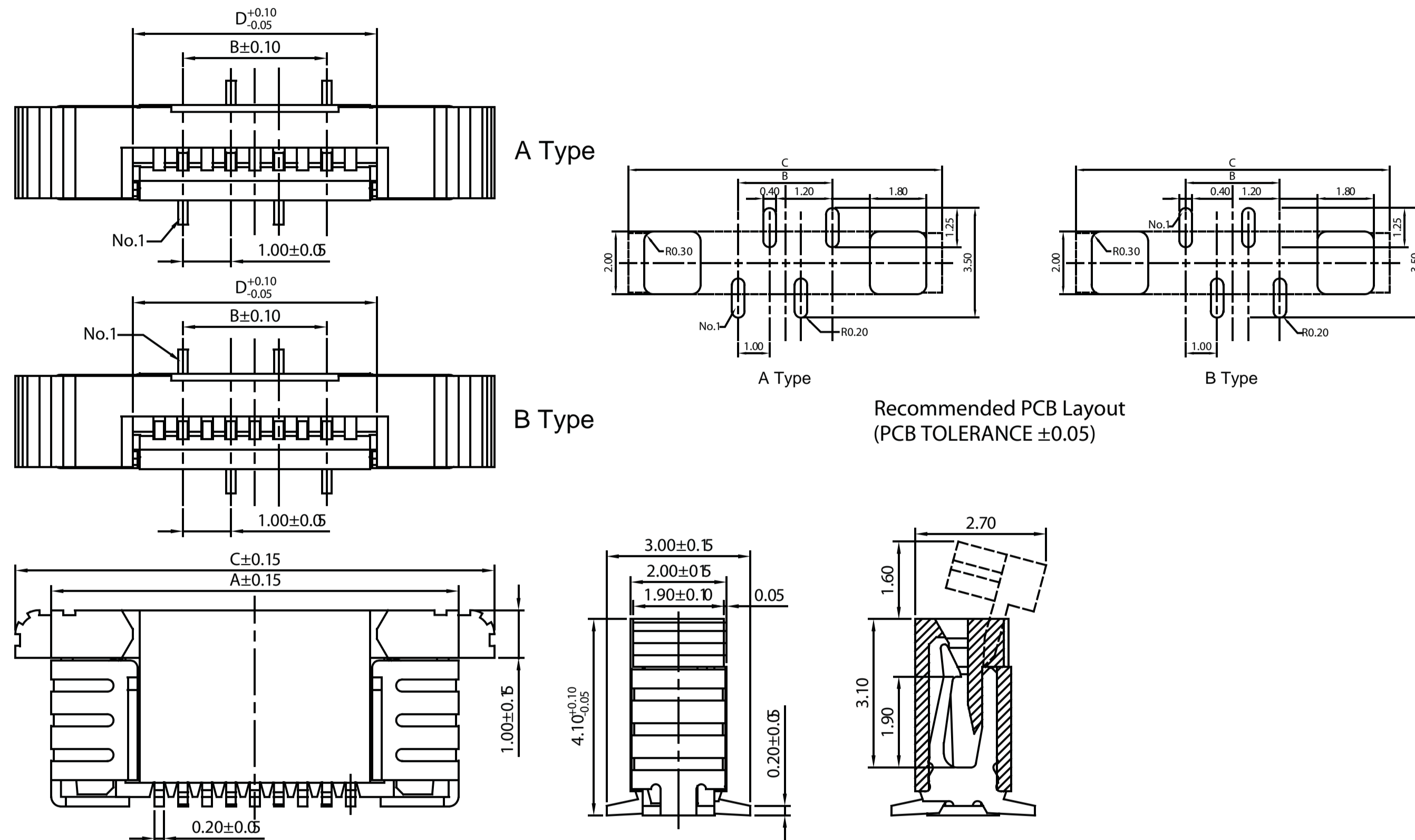

Recommended PCB Layout  
(PCB TOLERANCE  $\pm 0.05$ )

No. of Contacts	Dimensions			
	A	B	C	D
04	8.50	3.00	10.00	5.10
05	9.50	4.00	11.00	6.10
06	10.50	5.00	12.00	7.10
07	11.50	6.00	13.00	8.10
08	12.50	7.00	14.00	9.10
09	13.50	8.00	15.00	10.10
10	14.50	9.00	16.00	11.10
11	15.50	10.00	17.00	12.10
12	16.50	11.00	18.00	13.10
13	17.50	12.00	19.00	14.10
14	18.50	13.00	20.00	15.10
15	19.50	14.00	21.00	16.10
16	20.50	15.00	22.00	17.10
17	21.50	16.00	23.00	18.10
18	22.50	17.00	24.00	19.10
19	23.50	18.00	25.00	20.10
20	24.50	19.00	26.00	21.10
21	25.50	20.00	27.00	22.10
22	26.50	21.00	28.00	23.10
23	27.50	22.00	29.00	24.10
24	28.50	23.00	30.00	25.10

### TYPE 2

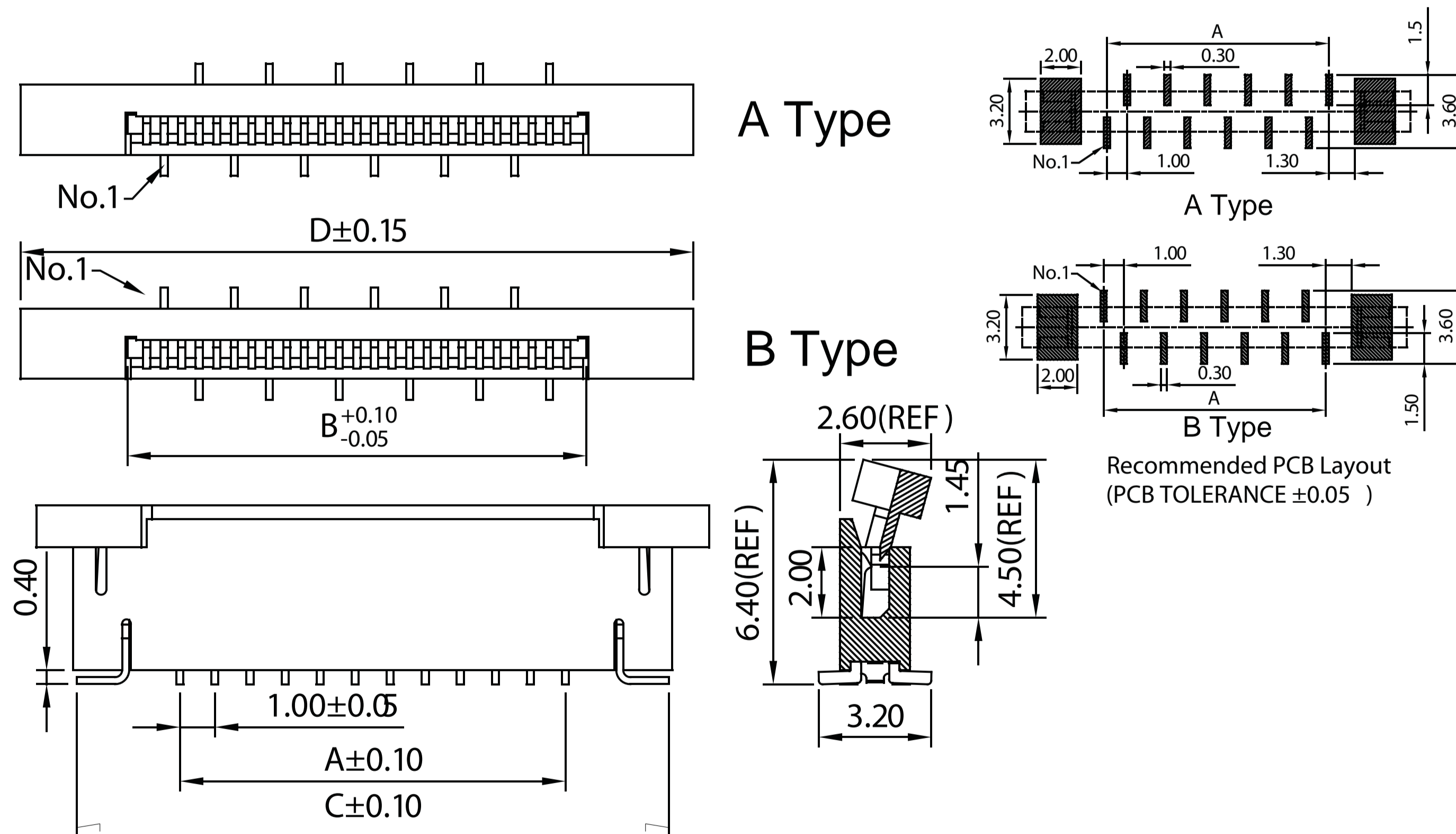

Recommended PCB Layout  
(PCB TOLERANCE  $\pm 0.05$ )

No. of Contacts	Dim. A	Dim. B	Dim. C	Dim. D	Dim. E
4	3.00	5.10	9.10	11.10	10.40
5	4.00	6.10	10.10	12.10	11.40
6	5.00	7.10	11.10	13.10	12.40
7	6.00	8.10	12.10	14.10	13.40
8	7.00	9.10	13.10	15.10	14.40
9	8.00	10.10	14.10	16.10	15.40
10	9.00	11.10	15.10	17.10	16.40
11	10.00	12.10	16.10	18.10	17.40
12	11.00	13.10	17.10	19.10	18.40
13	12.00	14.10	18.10	20.10	19.40
14	13.00	15.10	19.10	21.10	20.40
15	14.00	16.10	20.10	22.10	21.40
16	15.00	17.10	21.10	23.10	22.40
17	16.00	18.10	22.10	24.10	23.40
18	17.00	19.10	23.10	25.10	24.40
19	18.00	20.10	24.10	26.10	25.40
20	19.00	21.10	25.10	27.10	26.40
21	20.00	22.10	26.10	28.10	27.40
22	21.00	23.10	27.10	29.10	28.40
23	22.00	24.10	28.10	30.10	29.40
24	23.00	25.10	29.10	31.10	30.40
25	24.00	26.10	30.10	32.10	31.40
26	25.00	27.10	31.10	33.10	32.40
27	26.00	28.10	32.10	34.10	33.40
28	27.00	29.10	33.10	35.10	34.40
29	28.00	30.10	34.10	36.10	35.40
30	29.00	31.10	35.10	37.10	36.40

