

# 1SS511WS

## Silicon Epitaxial Planar Switching Diode

### Features

- Ultra high speed switching application
- Low forward voltage
- Fast reverse recovery time
- Small total capacitance

### PINNING

PIN	DESCRIPTION
1	Cathode
2	Anode

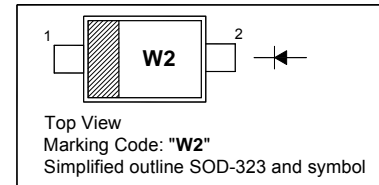

### Absolute Maximum Ratings ( $T_a = 25\text{ }^\circ\text{C}$ )

Parameter	Symbol	Value	Unit
Reverse Voltage	$V_R$	80	V
Peak Reverse Voltage	$V_{RM}$	85	V
Average Rectified Forward Current	$I_{F(AV)}$	100	mA
Peak Forward Current	$I_{FM}$	300	mA
Surge Forward Current (10 ms)	$I_{FSM}$	2	A
Power Dissipation	$P_{tot}$	150	mW
Junction Temperature	$T_j$	150	$^\circ\text{C}$
Storage Temperature Range	$T_{stg}$	- 55 to + 150	$^\circ\text{C}$

### Characteristics at $T_a = 25\text{ }^\circ\text{C}$

Parameter	Symbol	Max.	Unit
Forward Voltage at $I_F = 100\text{ mA}$	$V_F$	1.2	V
Reverse Current at $V_R = 80\text{ V}$	$I_R$	0.5	$\mu\text{A}$
Total Capacitance at $V_R = 0\text{ V}$ , $f = 1\text{ MHz}$	$C_{tot}$	4	pF
Reverse Recovery Time at $I_F = I_R = 10\text{ mA}$ , $I_{rr} = 0.1 \times I_R$ , $R_L = 100\ \Omega$	$t_{rr}$	4	ns

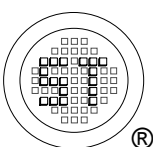

**SEMTECH ELECTRONICS LTD.**  
Subsidiary of Sino-Tech International (BVI) Limited



Dated : 15/06/2009

Fig. 1  $I_F$ - $V_F$

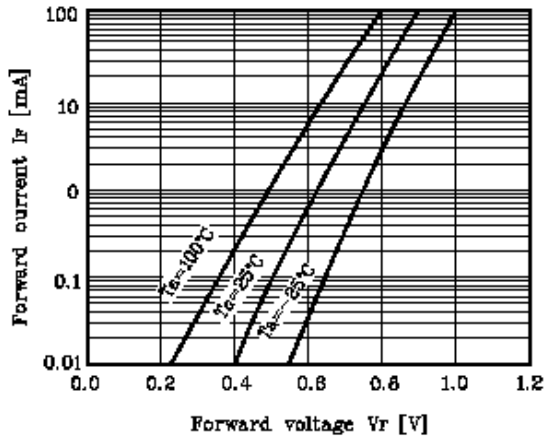

Fig. 2  $I_R$ - $V_R$

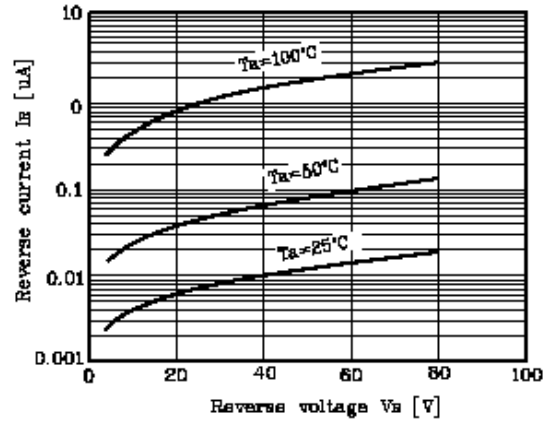

Fig. 3  $C_T$ - $V_R$

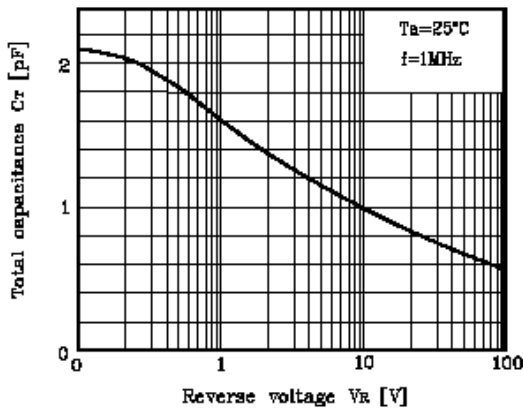
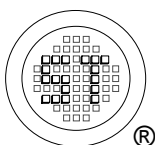
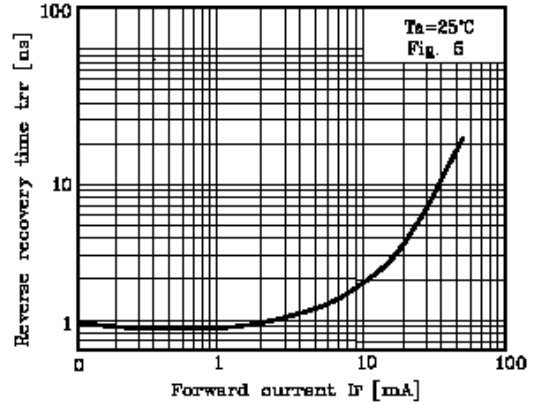

Fig. 4  $t_{rr}$ - $I_F$



**SEMTECH ELECTRONICS LTD.**  
Subsidiary of Sino-Tech International (BVI) Limited



## PACKAGE OUTLINE

Plastic surface mounted package; 2 leads

SOD-323

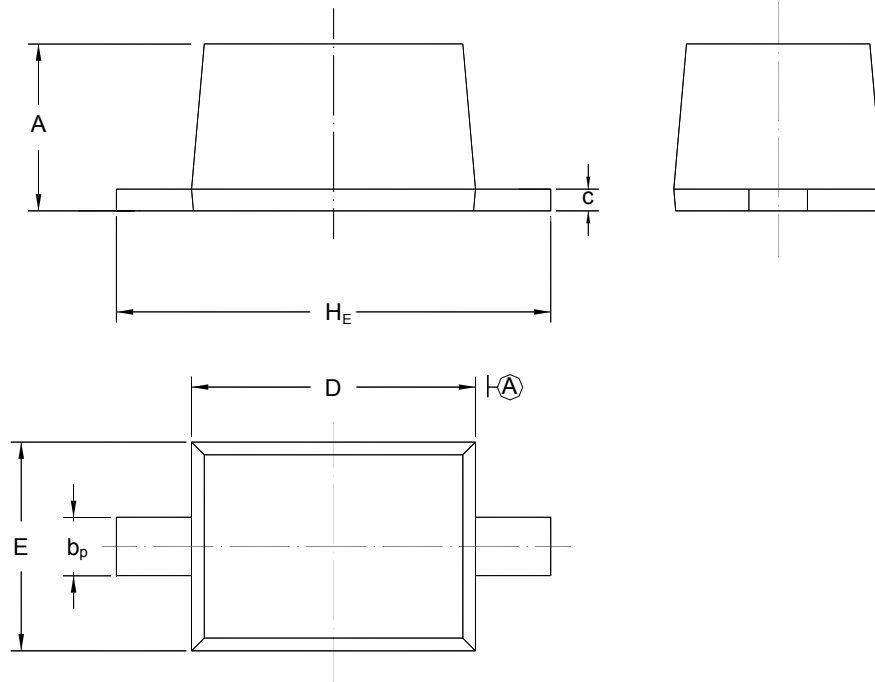

UNIT	A	b <sub>p</sub>	C	D	E	H <sub>E</sub>
mm	1.10 0.80	0.40 0.25	0.15 0.10	1.80 1.60	1.35 1.15	2.80 2.30

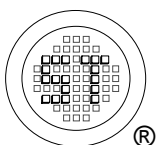

**SEMTECH ELECTRONICS LTD.**  
Subsidiary of Sino-Tech International (BVI) Limited



Dated : 15/06/2009