

## DESCRIPTION

Brightking's LES08C05L04 has been specifically designed to protect sensitive components which are connected to data and transmission lines from overvoltage caused by electrostatic discharge (ESD), electrical fast transients (EFT), and lightning. The low capacitance array configuration allows the user to protect four high-speed data or I/O lines. The high surge capability (500W,  $t_p=8/20\mu s$ ) makes the series suitable for telecommunication systems operating in harsh transient environments. The low inductance construction minimizes voltage overshoot during high current surges.



**HBM :  $\pm 8kV$**   
**Air Mode :  $\pm 15kV$**



## SPECIFICATION FEATURES

- IEC61000-4-2 ESD 15KV Air, 8KV contact compliance
- SOIC-08 surface mount package
- Protects four I/O lines
- Peak power dissipation of 500W under 8/20 $\mu s$  waveform
- Working voltage : 5V
- Low leakage current
- Low capacitance and clamping voltages
- Solid-state silicon avalanche technology
- Lead Free/RoHS compliant
- Solder reflow temperature: Pure Tin-Sn, 260-270 $^{\circ}C$
- Flammability rating UL 94V-0

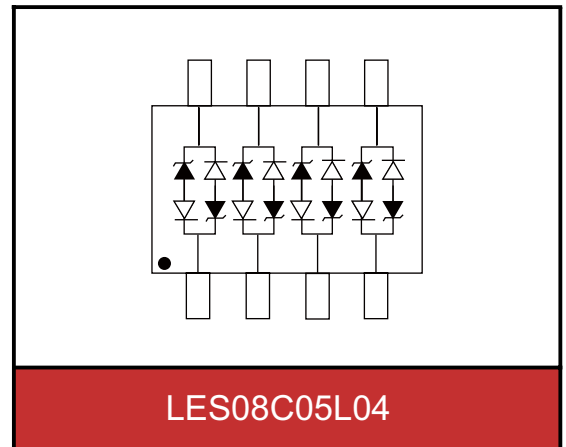

## APPLICATIONS

- Multi-Mode transceiver protection
- WAN equipment
  - CSU / DSU
  - Multiplexers
  - Routers
- RS-232 (V.28)
- RS-422 (V.11, X.21)
- Ethernet-10/100 base T
- Low-voltage ASICs

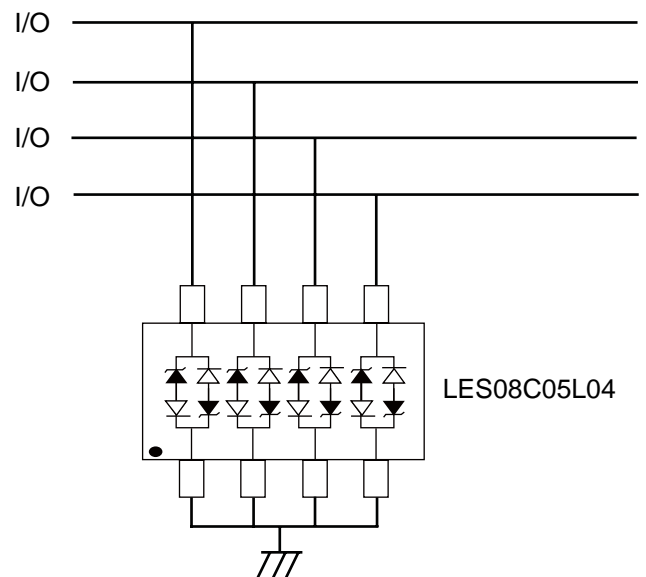

## MAXIMUM RATINGS

Rating	Symbol	Value	Unit
Peak pulse power (tp=8/20μs waveform)	Ppp	500	W
ESD voltage (HBM contact)	V <sub>ESD</sub>	±8	KV
ESD voltage (AIR contact)		±15	
Storage & operating temperature range	T <sub>STG</sub> ,T <sub>J</sub>	-55~+150	°C

## ELECTRICAL CHARACTERISTICS (T<sub>J</sub>=25°C)

LES08C05L04 (Marking:B LC05C-4)

Parameter	Symbol	Condition	Min.	Typ.	Max.	Unit
Reverse stand-off voltage	V <sub>RWM</sub>				5	V
Reverse breakdown voltage	V <sub>BR</sub>	I <sub>BR</sub> =1mA	6			V
Reverse leakage current	I <sub>R</sub>	V <sub>R</sub> =5V each I/O pin			10	μA
Clamping voltage (tp=8/20μs)	V <sub>C</sub>	I <sub>PP</sub> =1A			9.8	V
Clamping voltage (tp=8/20μs)	V <sub>C</sub>	I <sub>PP</sub> =10A			17	V
Off state junction capacitance	C <sub>J</sub>	0Vdc,f=1MHZ between I/O pins and GND			15	pF

**TYPICAL CHARACTERISTICS CURVES**

Figure 1. Power Derating Curve

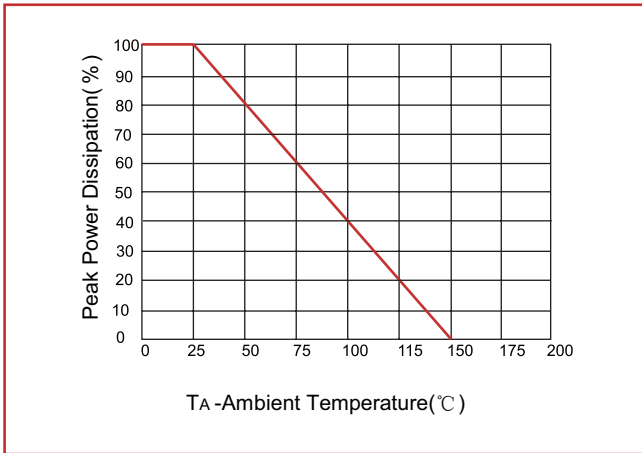

Figure 2. Pulse Waveforms

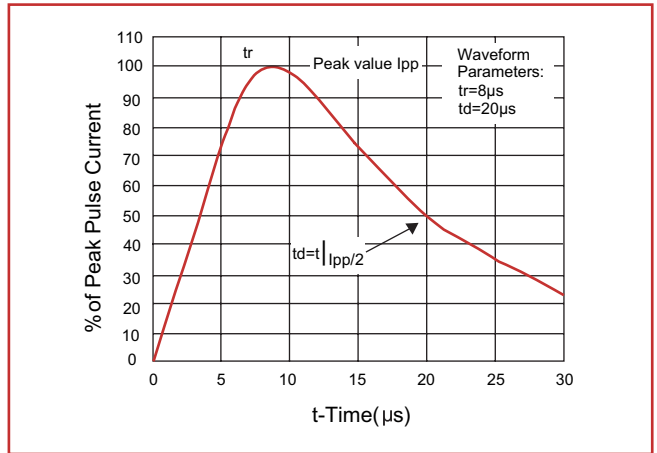

Figure 3. Non-Repetitive Peak Pulse vs Pulse Time

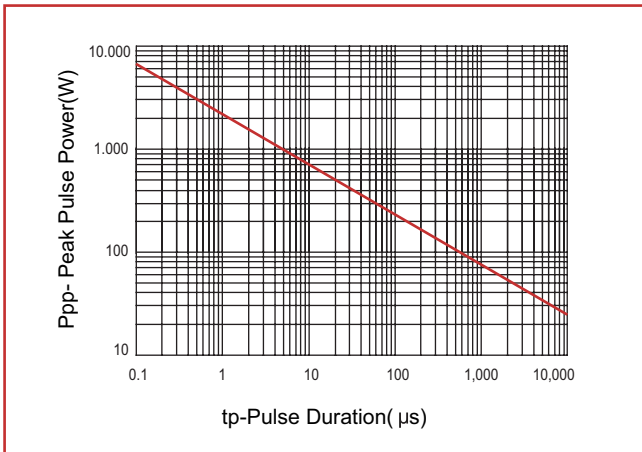
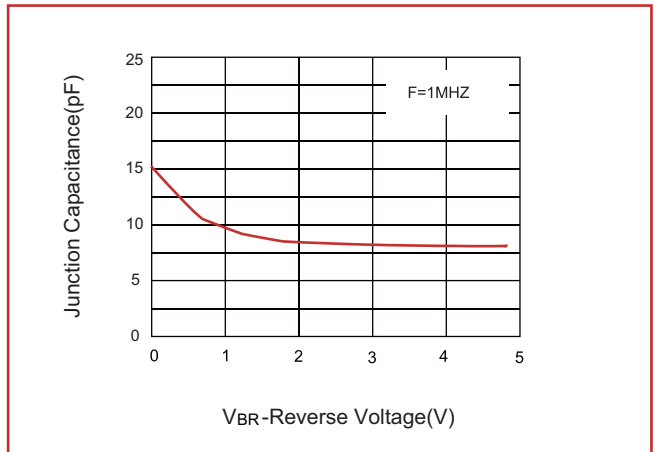
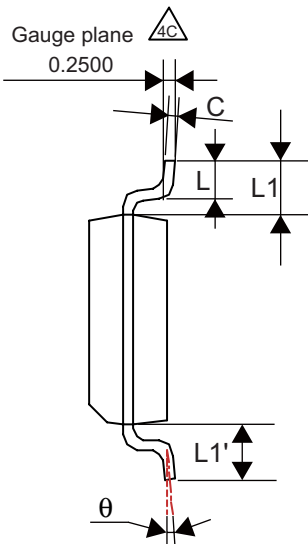
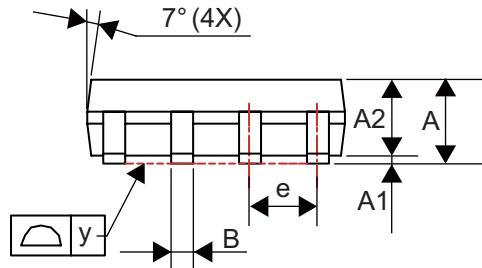
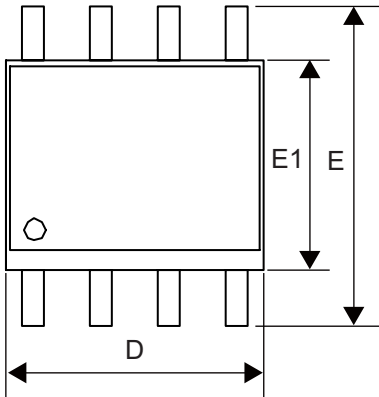

Figure 4. Capacitance vs. Reverse Voltage



**PACKAGE AND SUGGESTED PAD LAYOUT DIMENSION**

**SOIC-08(unit:mm)**



DIMENSIONS						
SYMBOL	INCHES			MILLIMETERS		
	MIN	NOM	MAX	MIN	NOM	MAX
A	0.053	0.063	0.069	1.35	1.60	1.75
A1	0.004	-	0.010	0.10	-	0.25
A2	-	0.057	-	-	1.45	-
B	0.013	-	0.020	0.33	-	0.51
C	0.007	-	0.010	0.19	-	0.25
D	0.189	-	0.197	4.80	-	5.00
E1	0.150	0.153	0.157	3.80	3.90	4.00
e	-	0.050	-	-	1.27	-
E	0.228	0.236	0.244	5.80	6.00	6.20
L	0.016	-	0.050	0.40	-	1.27
y	-	-	0.004	-	-	0.10
$\theta$	0°	-	8°	0°	-	8°
L1-L1'	-	-	0.005	-	-	0.12
L1	0.041REF			1.04REF		

