

WS2.8-8LVU

Transient Voltage Suppressor

Features

- 600 Watts peak pulse power ($t_p=8/20\mu s$)
- Protects Four Line Pairs (Eight lines)
- Low capacitance
- Low leakage current
- Low operating and clamping voltage
- Solid-state Punch through Avalanche TVS process technology

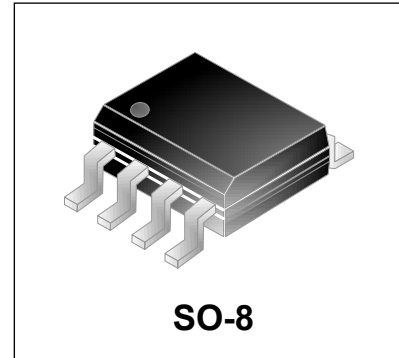

IEC COMPATIBILITY (EN61000-4)

- IEC 61000-4-2 (ESD) $\pm 15kV$ (air), $\pm 8kV$ (contact)
- IEC 61000-4-4 (EFT) 40A (5/50ns)
- IEC 61000-4-5 (Lightning) 24A (8/20 μs)

Mechanical Characteristics

- JEDEC SO-8 package
- Molding compound flammability rating: UL 94V-0
- Marking: Marking Code
- Packaging: Tape and Reel
- RoHS/WEEE Compliant

Applications

- Switching Systems
- WAN/LAN Equipment
- Desktops, Servers, Notebooks & Handhelds
- 10/100 Ethernet
- Base Stations
- Audio/Video Inputs

Schematic & PIN Configuration

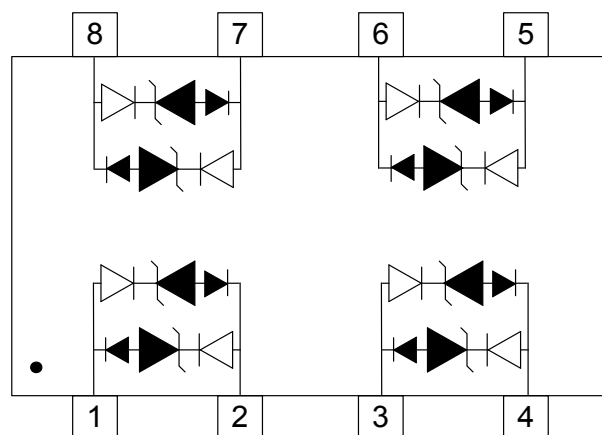

SO-8 (Top View)

Absolute Maximum Rating			
Rating	Symbol	Value	Units
Peak Pulse Power ($t_p=8/20\mu s$) see Figure1& Figure2	P_{PP}	600	Watts
Peak Pulse Current ($t_p=8/20\mu s$)	I_{PP}	30	A
Lead Soldering Temperature	T_L	260(10sec)	°C
Operating Temperature	T_J	-55 to + 125	°C
Storage Temperature	T_{STG}	-55 to +150	°C

Electrical Parameters (T=25°C)

Symbol	Parameter
I_{PP}	Maximum Reverse Peak Pulse Current
V_C	Clamping Voltage @ I_{PP}
V_{RWM}	Working Peak Reverse Voltage
I_R	Maximum Reverse Leakage Current @ V_{RWM}
V_{PT}	Punch-through Breakdown Voltage @ I_T
V_{SB}	Snap-Back Voltage @ I_{SB}
I_{SB}	Snap-Back Current
I_{PT}	Test Current
V_{PTF}	Forward Punch-through Breakdown Voltage @ I_F
I_{PTF}	Forward Test Current

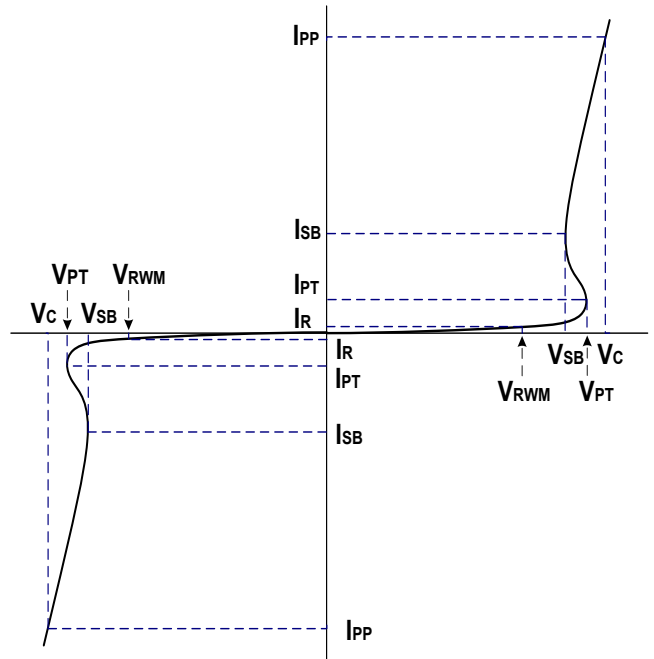

Electrical Characteristics(T=25°C)

WS2.8-8LVU						
Parameter	Symbol	Conditions	Minimum	Typical	Maximum	Units
Reverse Stand-Off Voltage	V_{RWM}	See Note1			2.8	V
Punch-through Voltage	V_{PT}	$I_{PT}=2\mu A$, See Note1	3.0			V
Reverse Leakage Current	I_R	$V_{RWM}=2.8V$ See Note1			1	μA
Snap-Back Voltage	V_{SB}	$I_{SB}=50mA$, See Note1	2.8			V

Electrical Characteristics (Cont.)

Parameter	Symbol	Conditions	Minimum	Typical	Maximum	Units
Clamping Voltage (Note1)	V_C	$I_{PP}=2A$, $t_p=8/20\mu s$ See Note1			6.0	V
Clamping Voltage	V_C	$I_{PP}=5A$, $t_p=8/20\mu s$ See Note1			9.5	V
Clamping Voltage	V_C	$I_{PP}=24A$, $t_p=8/20\mu s$ See Note1			17	V
Clamping Voltage	V_C	$I_{PP}=30A$, $t_p=8/20\mu s$ See Note1			20	V
Junction Capacitance	C_j	$V_R = 0V$, $f = 1MHz$ See Note1		6		pF

NOTES:

1. Device measured between pin 1 and 2, pin 3 and 4, pin 5 and 6, pin 7 and 8.
2. The 8/20 μs test pulse wave is shown in figure3, and the clamping voltage vs. I_{PP} is shown in figure4.
3. The Junction capacitance vs. Reverse Voltage is shown in figure5.
4. Each Steer Diode integrated in the WS2.8-8LVU reversely connected with a TVS Diode in series.

Typical Characteristics

Figure 1: Peak Pulse Power vs. Pulse Time

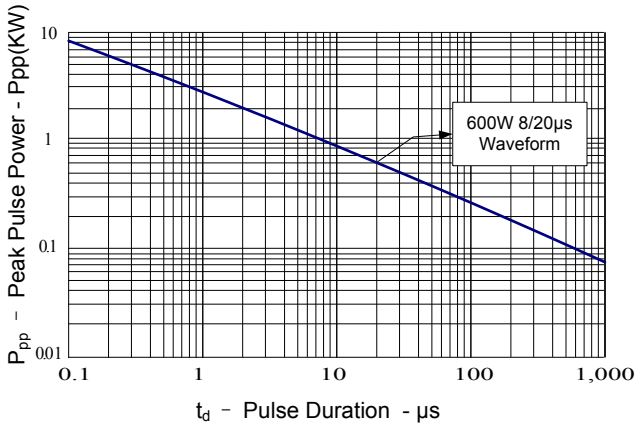

Figure 2: Power Derating Curve

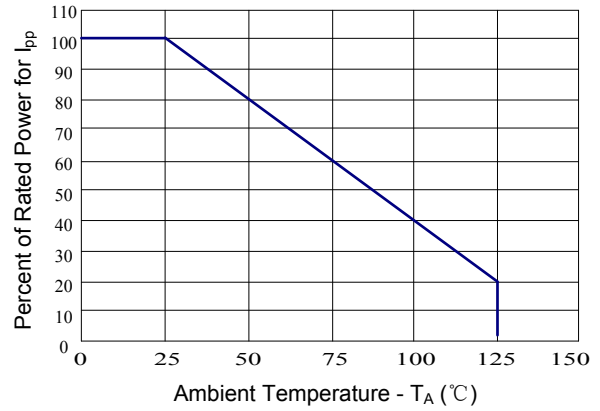

Figure 3: Pulse Waveform

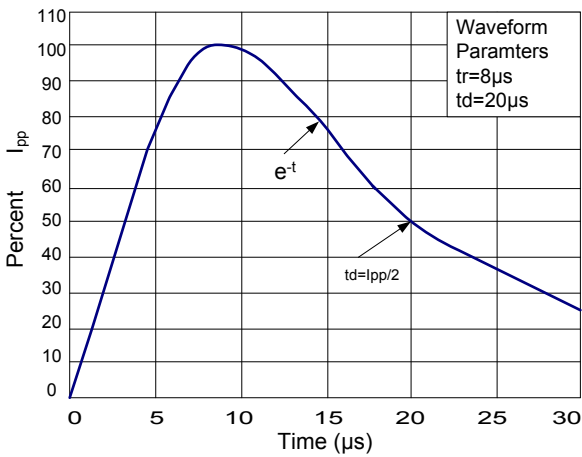

Figure 4: Clamping Voltage vs. Peak Pulse Current

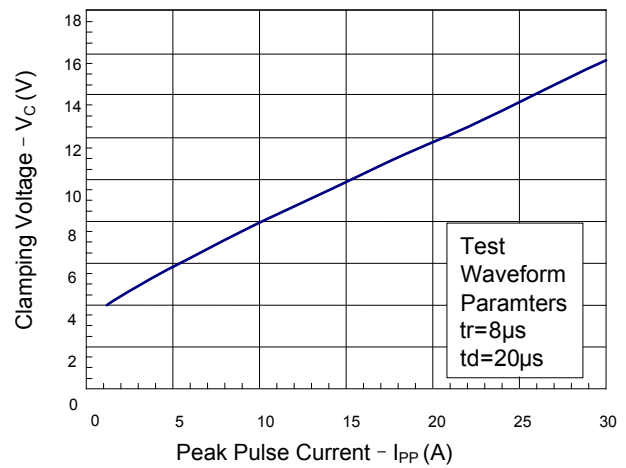
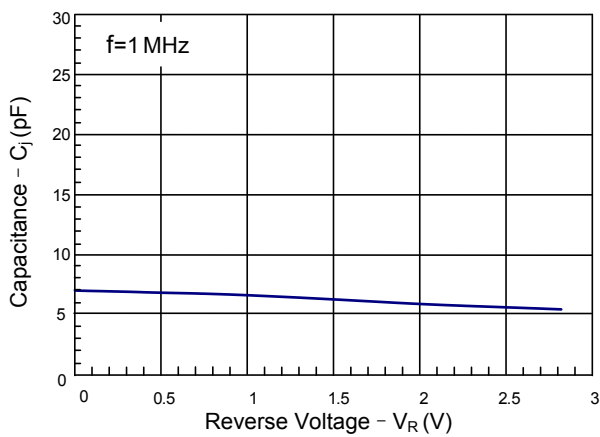

Figure 5: Capacitance vs. Reverse Voltage



Application Information

The WS2.8-8LVU is designed to providing protection for electronic equipment that is susceptible to damage caused by Electrostatic Discharge (ESD), Electrical Fast Transients (EFT) and tertiary lightning effects. This product is offered in a unidirectional configuration and provides both common-mode and differential-mode protection.

Bidirectional Common-mode Protection

The WS2.8-8LVU device provides four lines of bidirectional protection in a common-mode configuration .

- Pin 1 is connected to Line1
- Pin 8 is connected to Line2
- Pin 5 is connected to Line3
- Pin 8 is connected to Line4
- Other Pins are connected to ground

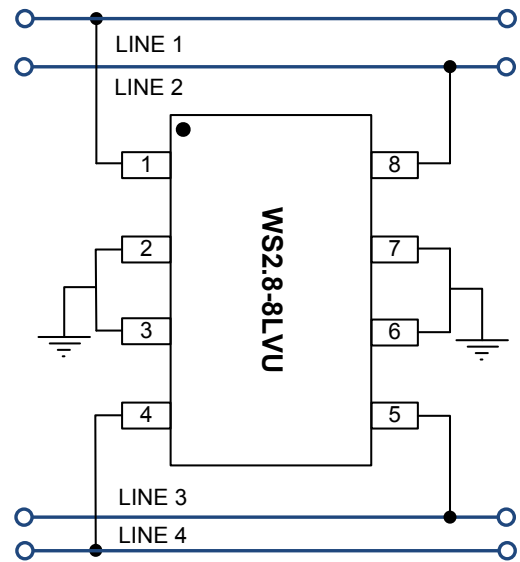

Bidirectional Differential-mode Protection

The WS2.8-8LVU device provides four line pairs of bidirectional protection in a differential-mode configuration.

- Line1&Line2 compose Line Pair1
- Line3&Line4 compose Line Pair2
- Line1&Line2 compose Line Pair1
- Line3&Line4 compose Line Pair4
- Pin 1&Pin2 is respectively connected to Line1&Line2
- Pin 3&Pin4 is respectively connected to Line3&Line4
- Pin 5&Pin6 is respectively connected to Line5&Line6
- Pin 7&Pin8 is respectively connected to Line7&Line8

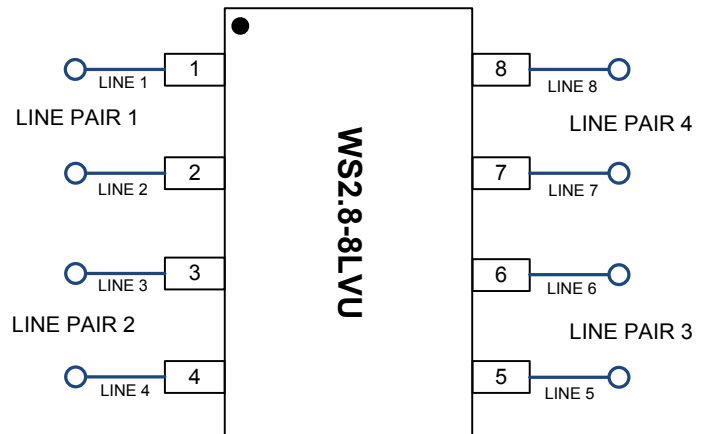

Main Application

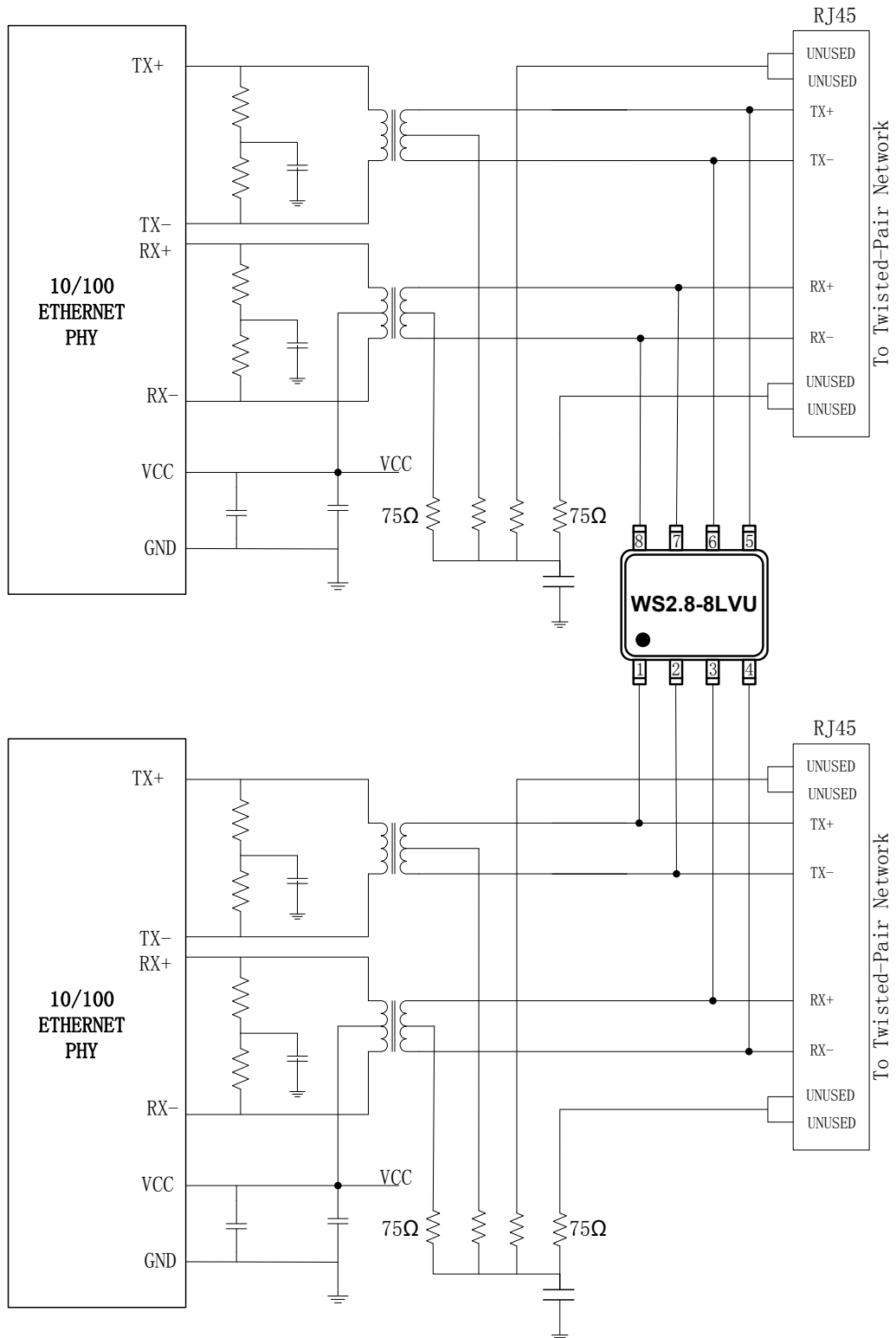

One WS2.8-8LVU Protecting Two 10/100 Ethernet Port

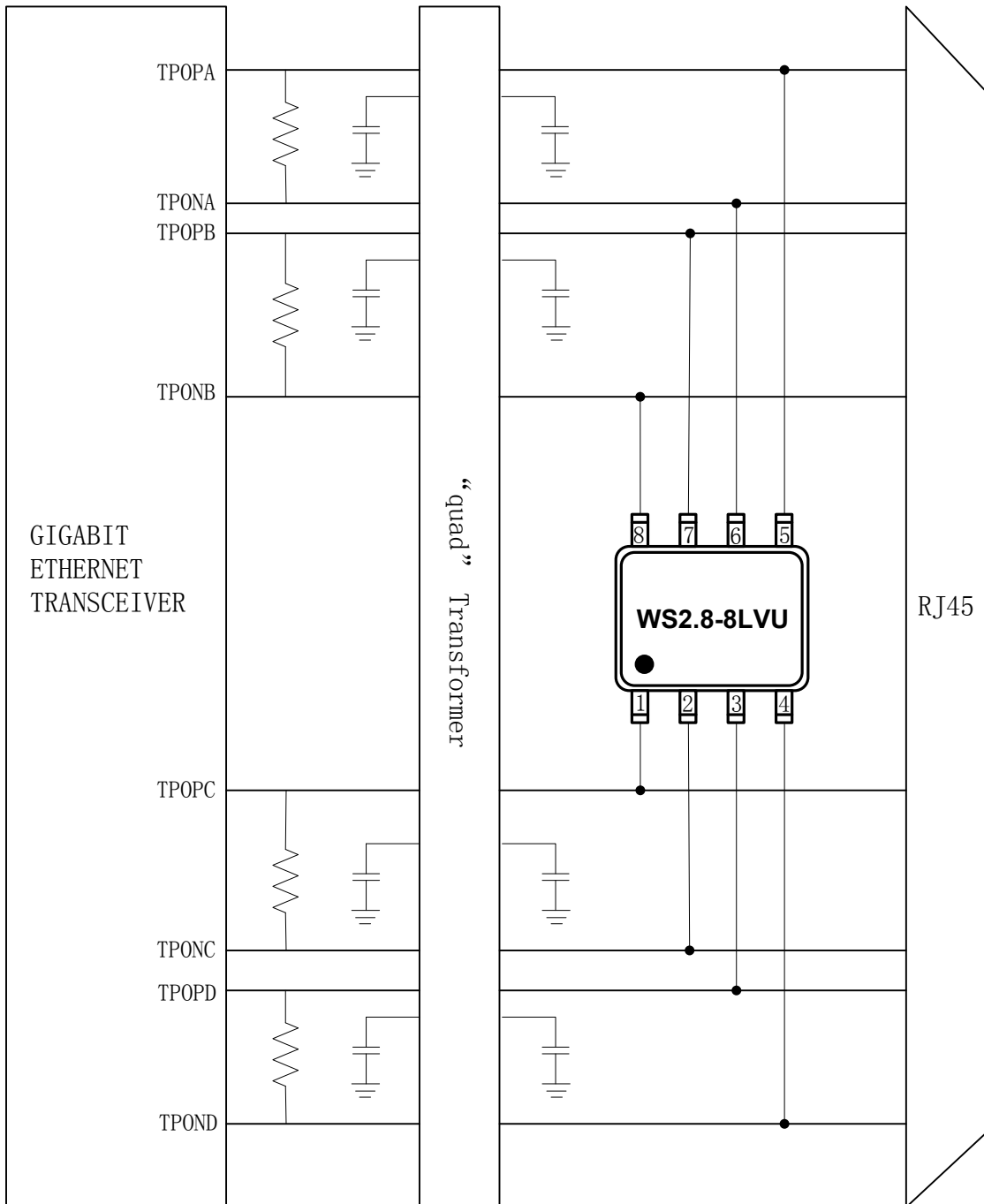

Gigabit Ethernet Protection Circuit

Outline Drawing – SO-8

PACKAGE OUTLINE

SO-8

DIMENSIONS

SYMBOL	INCHES		MILLIMETER	
	MIN	MAX	MIN	MAX
A	0.054	0.068	1.35	1.75
a1	0.004	0.008	0.10	0.25
a2	0.050	0.060	1.25	1.50
D	0.189	0.196	4.80	5.00
F	0.150	0.157	3.80	4.00
E	0.229	0.244	5.80	6.20
e	0.05BSC		1.27BSC	
L	0.016	0.049	0.40	1.250
θ	0°	10°	0°	10°

DIMENSIONS		
DIM	INCHES	MILLIMETERS
C	0.205	5.20
G	0.160	4.06
P	0.050	1.27
X	0.015	0.38
Y	0.045	1.14
Z	0.291	7.40

Notes

- This land pattern is for reference purposes only consult your manufacturing group to ensure your company's manufacturing guidelines are met.
- Reference ipc-sm-782a..

Marking Codes

Part Number	WS2.8-8LVU
Marking Code	WS2.8-8LVU