



### Features :

- Constant current mode power supply
- Universal AC input / Full range
- Fully encapsulated with IP67 level
- Protections: Short circuit / Over current
- Built-in active PFC function
- Small and compact size
- UL1310 Class 2 power unit, pass LPS
- 100% full load burn-in test
- Suitable for LED lighting and moving sign applications
- 2 years warranty

### SPECIFICATION:

MODEL		LA50P-700	LA50P-1050	LA50P-1400
OUTPUT	DC VOLTAGE	80V	48V	36V
	DC VOLTAGE RANGE	40-80V	24-48V	18-36V
	CURRENT RANGE	700 mA ±3%	1050mA ±3%	1400mA ±3%
	RATED POWER	56W	50.4W	50.4W
	RIPPLE & NOISE (max.)	5Vp-p	5Vp-p	5Vp-p
	VOLTAGE TOLERANCE	±3.0%		
	LINE REGULATION	±1.0%		
	LOAD REGULATION	±2.0%		
SETUP,RISE TIME	1500ms,250ms/230VAC 3000ms,250ms/115ac at full load			
INPUT	VOLTAGE RANGE	100-240VAC		
	FREQUENCY RANGE	47~63Hz		
	EFFICIENCY (Typ.)	85% full load	85% full load	85% full load
	POWER FACTOR	PF>0.9/230VAC PF>0.95/115VAC at full load		
	AC CURRENT	1A/100AC 0.5A/240AC		
	INRUSH CURRENT(max.)	COLD STAT 70A/230VAC		
	LEAKAGE CURRENT	0.5mA/240VAC		
PROTECT ON	OVER CURRENT	Above 105% rated output power. Protection type: Hiccup mode, recovers automatically after fault condition is removed.		
	OVER TEMPERATURE	Tj 140°C typically(U1) Detect on main control IC Protection type: Hiccup mode, recovers automatically after temperature goes down		
ENVIRONMENT	WORKING TEMP.	-10~50°C		
	WORKING HUMIDITY	20~90% RH non-condensing		
	STORAGE TEMP., HUMIDITY	-40~80°C, 10~95% RH		
	TEMP.COEFFICIENT	±0.03%/°C (0~50°C)		
	VIBRATION	10 ~ 500Hz, 2G 10min./1cycle, period for 60min. each along X,Y, Z axes		
SAFETY & EMC	SAFETY STANDARDS	Design refer to UL1310 Class 2,TUV EN60950-1, EN61347-2-13, CAN/CSA C22.2 No. 223-M91, meet IP67		
	WITHSTAND VOLTAGE	I/P-O/P:3KVAC		
	ISOLATION RESISTANCE	I/P-O/P:>100M Ohms / 500VDC / 25~70% RH		
	EMI CONDUCTION & RADIATION	Compliance to EN55022 (CISPR22) Class B		
	HARMONIC CURRENT	Compliance to EN61000-3-2,-3		
	EMS IMMUNITY	Compliance to EN61000-4-2,3,4,5,6,8,11; ENV50204, EN55024, light industry level, criteria A		
DIMENSION		148*40*30mm (L*W*H)		

### Mechanical Specification

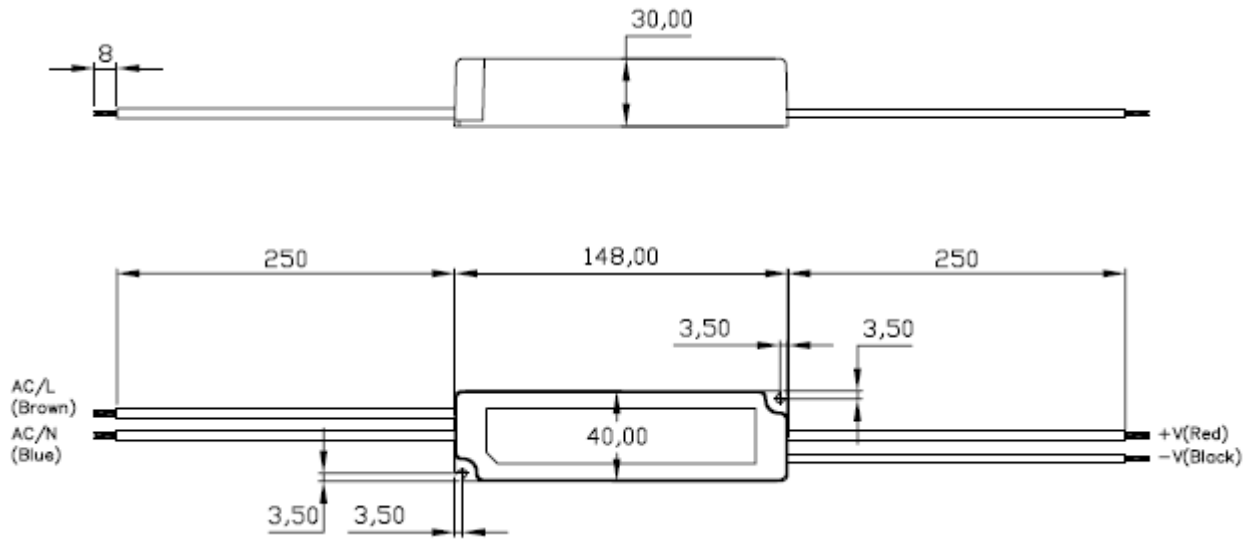

### Block Diagram

