

SPECIFICATION FOR APPROVAL

REF : 20100129-G

PAGE: 1

PROD. NAME	WOUND CHIP INDUCTOR	ABC'S DWG NO.	CM4532□□□□L□-□□□
		ABC'S ITEM NO.	

I . CONFIGURATION & DIMENSIONS :

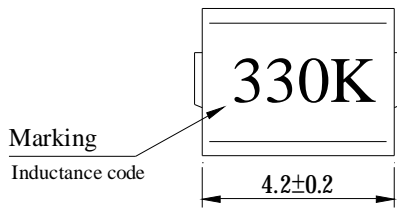

- A : 4.5±0.3 m/m
- B : 3.2±0.2 m/m
- C : 3.2±0.2 m/m
- E : 1.2 m/m
- F : 1.0^{+0.3}₋₀ m/m

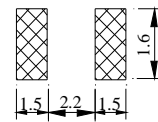
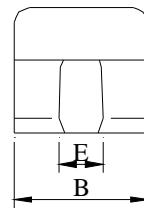
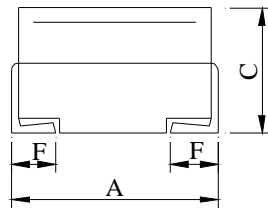

(PCB Pattern)

II . SCHEMATIC DIAGRAM :



III . MATERIALS :

- a . Core : Ferrite DR core
- b . Wire : Enamelled copper wire (class H)
- c . Terminal : Cu/Sn
- d . Encapsulate : Epoxy novolac molding compound
- e . Remark : Products comply with RoHS' requirements

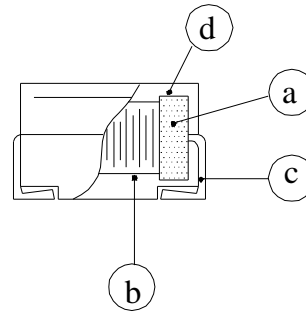

IV . GENERAL SPECIFICATION :

- a . Temp. rise : 20°C max.
- b . Ambient temp. : 100°C max.
- c . Storage temp. : -40°C ----+125°C
- d . Operating temp. : -40°C ----+125°C
- e . Terminal pull strength : 1.5 kg min.
- f . Rated current : Current cause
inductance drop within 10%
- g . Resistance to solder heat : 260°C .10 secs.
- h . Resistance to solvent : Per MIL-STD-202F

Reflow profile
 Peak Temp : 250°C max.
 Max time above 245°C : 20-40sec max.
 Max time above 217°C : 60-150sec max.
 200°C~250°C Average Ramp-up Rate : 3°C/second max.

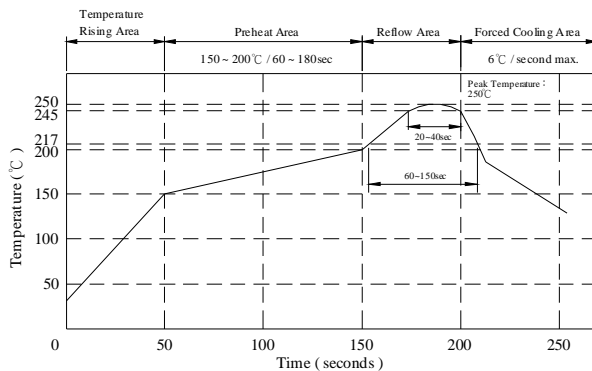

AR-001A

SPECIFICATION FOR APPROVAL

REF: 20100129-G

PAGE: 2

PROD. NAME	WOUND CHIP INDUCTOR	ABC'S DWG NO.	CM4532□□□□L□-□□□
		ABC'S ITEM NO.	

V . ELECTRICAL CHARACTERISTICS :

DWG No.	Inductance (μH)	Q min.	Test Freq. (MHz)	SRF (MHz) min.	RDC (Ω) max.	IDC (mA) max.
CM4532R10ML□-□□□	0.10 ±20%	35	25.2	300	0.18	800
CM4532R12ML□-□□□	0.12 ±20%	35	25.2	280	0.20	770
CM4532R15ML□-□□□	0.15 ±20%	35	25.2	250	0.22	730
CM4532R18ML□-□□□	0.18 ±20%	35	25.2	220	0.24	700
CM4532R22ML□-□□□	0.22 ±20%	40	25.2	200	0.25	665
CM4532R27ML□-□□□	0.27 ±20%	40	25.2	180	0.26	635
CM4532R33ML□-□□□	0.33 ±20%	40	25.2	165	0.28	605
CM4532R39ML□-□□□	0.39 ±20%	40	25.2	150	0.30	575
CM4532R47ML□-□□□	0.47 ±20%	40	25.2	145	0.32	545
CM4532R56ML□-□□□	0.56 ±20%	40	25.2	140	0.36	520
CM4532R68ML□-□□□	0.68 ±20%	40	25.2	135	0.40	500
CM4532R82ML□-□□□	0.82 ±20%	40	25.2	130	0.45	475
CM45321R0KL□-□□□	1.00 ±10%	50	7.96	100	0.50	450
CM45321R2KL□-□□□	1.20 ±10%	50	7.96	80	0.55	430
CM45321R5KL□-□□□	1.50 ±10%	50	7.96	70	0.60	410
CM45321R8KL□-□□□	1.80 ±10%	50	7.96	60	0.65	390
CM45322R2KL□-□□□	2.20 ±10%	50	7.96	55	0.70	380
CM45322R7KL□-□□□	2.70 ±10%	50	7.96	50	0.75	370
CM45323R3KL□-□□□	3.30 ±10%	50	7.96	45	0.80	355
CM45323R9KL□-□□□	3.90 ±10%	50	7.96	40	0.90	330
CM45324R7KL□-□□□	4.70 ±10%	50	7.96	35	1.00	315
CM45325R6KL□-□□□	5.60 ±10%	50	7.96	33	1.10	300
CM45326R8KL□-□□□	6.80 ±10%	50	7.96	27	1.20	285
CM45328R2KL□-□□□	8.20 ±10%	50	7.96	25	1.40	270
CM4532100KL□-□□□	10.00 ±10%	50	2.52	20	1.60	250
CM4532120KL□-□□□	12.00 ±10%	50	2.52	18	2.00	225
CM4532150KL□-□□□	15.00 ±10%	50	2.52	17	2.50	200
CM4532180KL□-□□□	18.00 ±10%	50	2.52	15	2.80	190
CM4532220KL□-□□□	22.00 ±10%	50	2.52	13	3.20	180
CM4532270KL□-□□□	27.00 ±10%	50	2.52	12	3.60	170
CM4532330KL□-□□□	33.00 ±10%	50	2.52	11	4.00	160
CM4532390KL□-□□□	39.00 ±10%	50	2.52	10	4.50	150
CM4532470KL□-□□□	47.00 ±10%	50	2.52	10	5.00	140
CM4532560KL□-□□□	56.00 ±10%	50	2.52	9.0	5.50	135
CM4532680KL□-□□□	68.00 ±10%	50	2.52	9.0	6.00	130
CM4532820KL□-□□□	82.00 ±10%	50	2.52	8.0	7.00	120
CM4532101KL□-□□□	100.00 ±10%	40	0.796	8.0	8.00	110
CM4532121KL□-□□□	120.00 ±10%	40	0.796	6.0	8.00	110
CM4532151KL□-□□□	150.00 ±10%	40	0.796	5.0	9.00	105
CM4532181KL□-□□□	180.00 ±10%	40	0.796	5.0	9.50	102
CM4532221KL□-□□□	220.00 ±10%	40	0.796	4.0	10.00	100
CM4532271KL□-□□□	270.00 ±10%	40	0.796	4.0	12.00	92
CM4532331KL□-□□□	330.00 ±10%	40	0.796	3.5	14.00	85
CM4532391KL□-□□□	390.00 ±10%	40	0.796	3.0	18.00	80
CM4532471KL□-□□□	470.00 ±10%	40	0.796	3.0	26.00	62
CM4532561KL□-□□□	560.00 ±10%	30	0.796	3.0	30.00	50
CM4532681KL□-□□□	680.00 ±10%	30	0.796	3.0	30.00	50
CM4532821KL□-□□□	820.00 ±10%	30	0.796	2.5	35.00	30
CM4532102KL□-□□□	1000.00 ±10%	20	0.252	2.5	40.00	30

- 1). □ : Packaging information ... A : Bulk B : Taping Reel
 2). "-□□□":Reference code

AR-001A



SPECIFICATION FOR APPROVAL

REF : 20100129-G

PAGE: 3

PROD. NAME	WOUND CHIP INDUCTOR	ABC'S DWG NO. ABC'S ITEM NO.	CM4532□□□□L□-□□□
---------------	----------------------------	---------------------------------	------------------

VI . CURVE :

@ Inductance VS. DC Superposition Characteristics

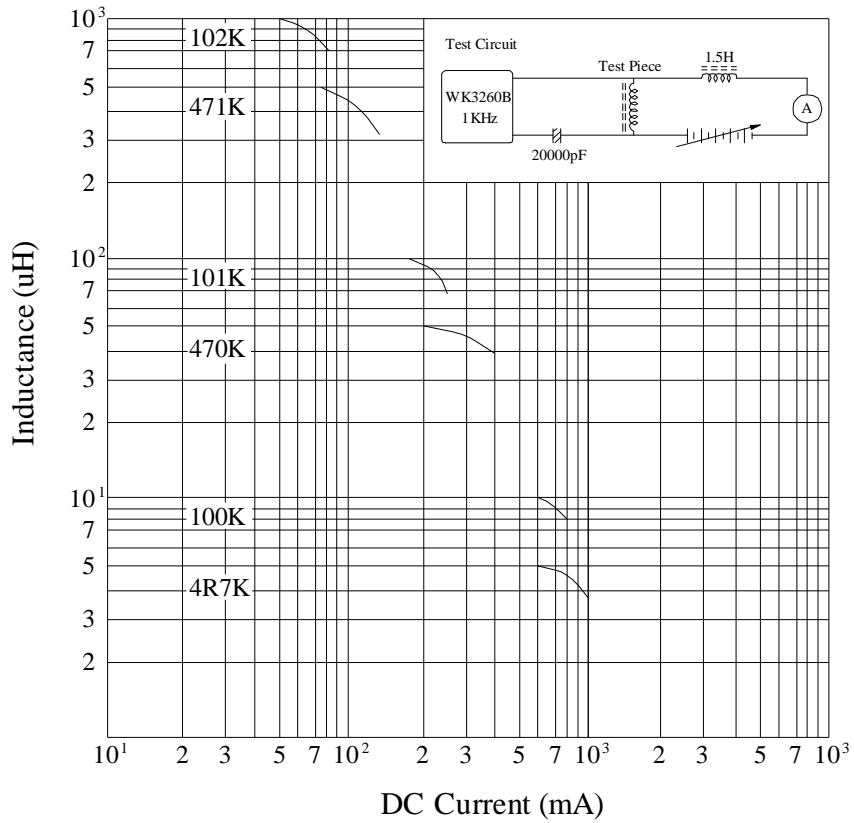

@ Q VS. Frequency Response

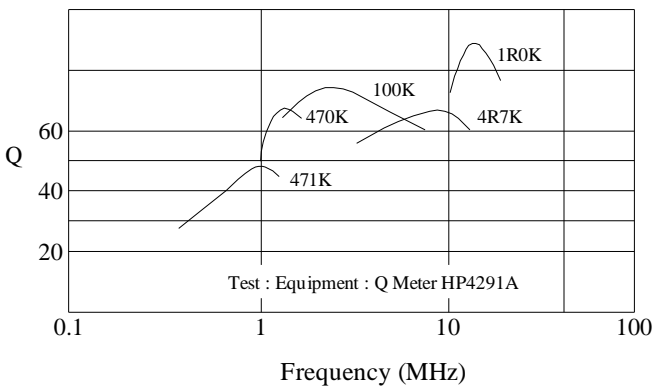

@ Inductance Change VS. Temperature Response

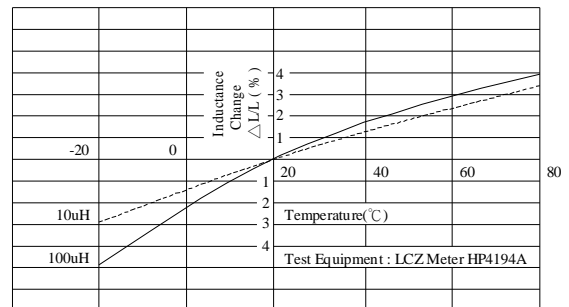

AR-001A

SPECIFICATION FOR APPROVAL

REF 20100129-G

PAGE: 4

PROD. NAME	WOUND CHIP INDUCTOR	ABC'S DWG NO.	CM4532□□□□L□-□□□
		ABC'S ITEM NO.	

VII . PACKAGING INFORMATION :

(1) Configuration

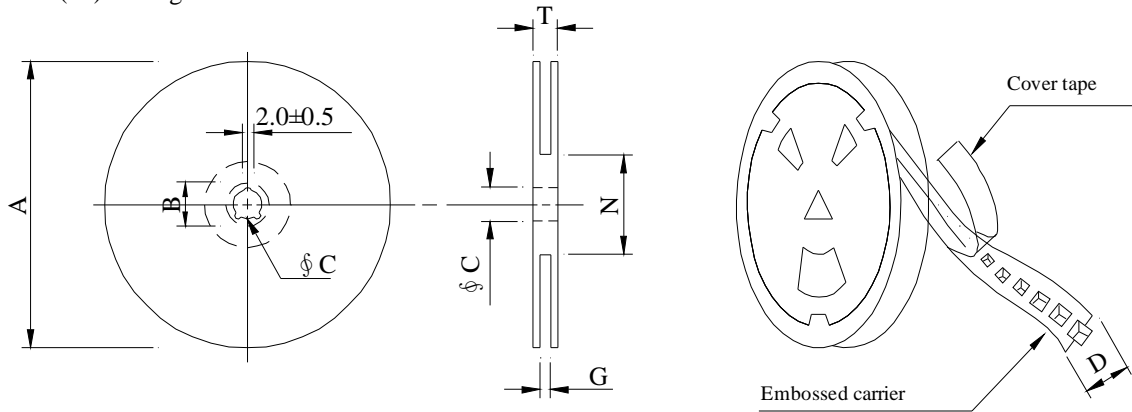

※Carrier tape width : D

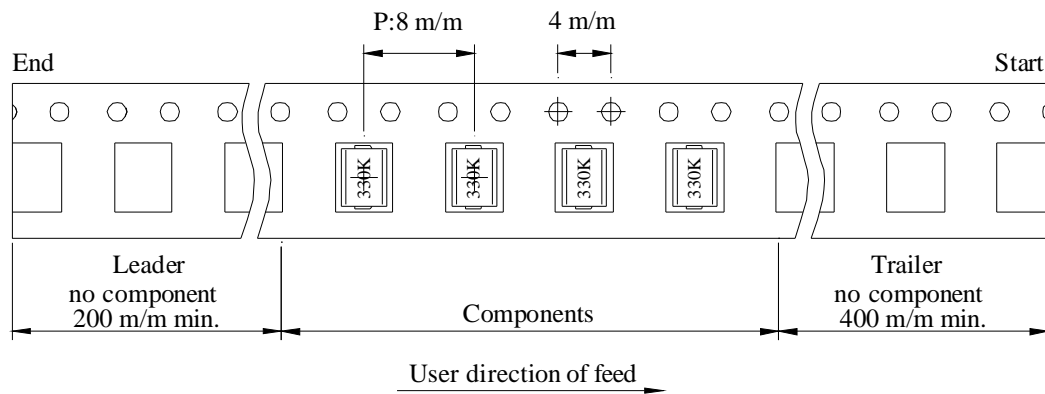

※ There is no differentiation or directions of polarity (marking) in the packaging method.

(2) Dimensions

Unit:m/m

Style	A	B	C	D	G	N	T
07 - 12	178	21±0.8	13	12	14 ⁺⁰	50 ⁻⁰	16.5
13 - 12	330	21±0.8	13±0.5	12	14 ⁺⁰	50 ⁻⁰	18.4

(3) Q'TY & G.W. Pe package

Series	Inner : Reel			Outer : Carton		
	Q'TY (pcs)	G.W. (gw)	Style	Q'TY (pcs)	G.W. (Kg)	Size (cm)
CM4532	500	130	07 - 12	20,000	7.20	41 x 39 x 22
CM4532	2000	540	13 - 12	18,000	6.50	41 x 39 x 22

AR-001A



千如電子集團
ABC ELECTRONICS GROUP.

SPECIFICATION FOR APPROVAL

PROD. NAME	WOUND CHIP INDUCTOR	ABC'S DWG NO.	CM4532□□□□L□-□□□
		ABC'S ITEM NO.	

VIII . DWGING NUMBER EXPRESSION :

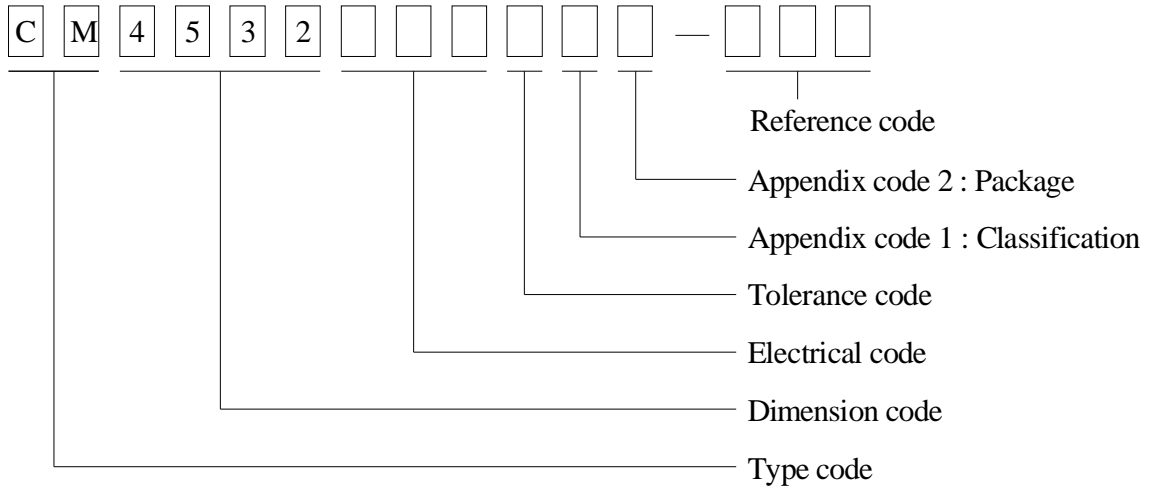

Appendix code 1 : Product Classification

- L : Lead Free Standard products comply with RoHS' requirements
- 1 ~ 9 : Lead Free Special products comply with RoHS' requirements

Appendix code 2 : Package Information

Code	Inner package	Inner package Q'TY	Remark
A	Bag	500 pcs	
B	T / R (Reel package)	500 pcs	UCT
C	T / R (Reel package)	2,000 pcs	UCT
D	T / R (Reel package)	500 pcs	UCT
E	T / R (Reel package)	2,000 pcs	UCT
F	T / R (Reel package)	2,000 pcs	UCT blue reel
G	T / R (Reel package)	1,000 pcs	UCT blue reel

Note : ① package code "E" :

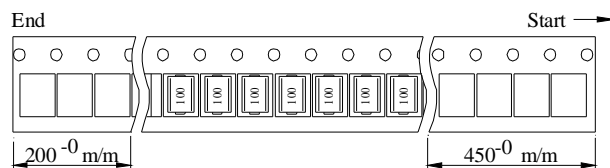

SPECIFICATION FOR APPROVAL

REF: 20100129-G

PAGE: 6

PROD. NAME	WOUND CHIP INDUCTOR	ABC'S DWG NO.	CM4532□□□□L□-□□□
		ABC'S ITEM NO.	

IX . RELIABILITY TEST :

Test item	Specification	Test condition / Test method
● Electrical performance test		
Inductance L	Refer to standard electrical characteristic list	□HP4194A with HP-16034E test fixture
Q		
Self resonance frequency SRF		□HP4291A with HP-16093A test fixture
DC Resistance RDC		CH-502AC
Rated current IDC		Applied the current to coils , The Inductance change shall be less than 10% to initial value & temperature rise shall not be more than 20°C
Temperature rise test	20°C max.	1 . Applied the allowed DC current for 10 minutes 2 . Temperature measure by digital surface thermometer
Over load test	After test , Inductors shall be no evidence of electrical and mechanical damage	Applied 2 times of rated allowed DC current to inductor for a period of 5 minutes
Withstanding voltage test	After tset , Inductors shall be no evidence of electrical and mechanical damage	AC voltage of 1000VAC applied between inductors terminal and coating for 5 seconds
Insulation resistance test	1000 MΩ min .	100 VDC applied between inductor terminal and coating
● Mechanical performance test		
Vibration test (Low frequency)	1 . Inductors shall be no evidence of electrical and mechanical damage	1 . Amplitude : 1.5 m/m 2 . Frequency : 10 -- 55 -- 10 Hz / 1min. 3 . Direction : X , Y , Z 4 . Duration : 2 hrs / X , Y , Z
Shock test	2 . Inductance shall not change more than±5%	Inductors shall be dropped 10 times from a height of 1m onto 3cm wooden board
Resistance to soldering heat	3 . Q Shall not change more than ±20%	Temp : 260±5°C Time : 10±1.0 sec.

AR-001A



SPECIFICATION FOR APPROVAL

REF : 20100129-G

PAGE: 7

PROD. NAME	WOUND CHIP INDUCTOR	ABC'S DWG NO.	CM4532□□□□L□-□□□
		ABC'S ITEM NO.	
Terminal strength-pull test	Terminal shall not be loosened or ruptured	A 0.5kg load shall be applied to both Terminals in the axis direction for 1 minute .	
Solderability test	The terminal shall be at least 90% covered with solder	After fluxing , Inductor shall be dipped in a melted solder bath at 240±5°C for 5 seconds .	
Resistance to solvent test	There shall be no case deformation change in appearance or obliteration of marking	MIL-STD-202F , Method 215D	
● Climatic test			
Temperature characteristic	1 . Inductors shall be no evidence of electrical and mechanical damage 2 . Inductance shall not change more than ±10% 3 . Q shall not change more than ±20%	-40°C -- +125°C	
Humidity test		1 . Temp : 40±2°C 2 . R.H. : 90 -- 95% 3 . Time : 96±2 hours	
Cold test		1 . Temp : -25±2°C 2 . Time : 96±2 hours	
Thermal shock test		<p style="text-align: center;">Total : 5 cycles</p>	
Dry heat test		1 . Temp : 85±2°C 2 . Time : 96±2 hours	
High temperature load life test	There shall be no evidence of short or open circuiting	1 . Temp : 85±2°C 2 . Time : 1000±12 hours 3 . Load : Allowed DC current	
Humidity load life		1 . Temp : 40±2°C 2 . R.H. : 90 -- 95% 3 . Time : 1000±12 hours 4 . Load : Allowed DC current	
● Note : Unless otherwise specified , Allow the specimen to stand at room temperature for 1 hour or more but not more than 2 hours , Measure the electrical and mechanical performances			

AR-001A

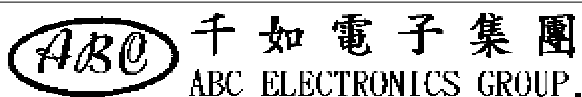

SPECIFICATION FOR APPROVAL

REF : 20100129-G

PAGE: 8

PROD. NAME	WOUND CHIP INDUCTOR	ABC'S DWG NO.	CM4532□□□□L□-□□□
		ABC'S ITEM NO.	

X . UL CARD :

OBMW2 August 27, 1999
 Magnet Wire-Component

ELEKTRISOLA (MALAYSIA) SDN BHD E143312
 IALAN DAMN SATU IANDA BAIK 28750 BENTONG, PAHANG
 DARUL MAKMUR MALAYSIA

Mtl Dsg	Mark Dsg	Coating Type		ANSI Typ	Temp Class
		BC	OC		
Estersol 160	E180	Polyesterimide (solderable)	—	MW-77	180
Amldester 200	A200	Polyesterimide	—	MW-74	200
Polysol-N 155	PN155	Polyurethane	Nylon	MW-80, MW-28	155, 100
Polysol 155	P155	Polyurethane	—	MW-79, MW-79	155, 130
Polysol 155g	Pg155	Polyurethane	—	MW-79	130
Polysol 155p	Pp155.Gp155	Polyurethane	—	MW-79	155
Polysol 160	P160	Polyurethane	—	MW-79	155
Polysol 180	P180	Polyurethane	—	MW-79	155
Polysol 170	P170 or G170	Polyurethane	—	MW-79	156
Polysol-N 180	PN180	Polyurethane	Nylon	—	180

Marking : Company name/material designation or marked designation and factory identification on package ok reel

See General Information preceding These Recognitions
 For use only in equipment where the acceptability of the combination is determined by Underwriters Laboratories Inc.

OMFZ2 March 4, 1994
 Component-Plastics

CHANG CHUN PLASTICS CO LTD E59481 (S)
(F1-cont. from F card)

BM-21	ALL	0.79	94HB	50	50	50	—	—	—	—
BM-22	ALL	0.79	94HB	50	50	50	—	—	—	—
BM-23	ALL	0.79	94V-0	50	50	50	—	—	—	—
EME-1100	BK	0.84	94V-0	130	130	130	—	—	—	—
	BK	6.4	94V-0	130	130	130	—	—	—	—
EME-1200	BK	0.84	94V-0	130	130	130	—	—	—	—
	BK	6.4	94V-0	130	130	130	—	—	—	—
EME-5961C	BK	0.3	94V-0	130	130	130	—	—	—	—
	BK	3.1	94V-0	130	130	130	—	—	—	—

Reports: January 19, 1988: January 19, 1988: January 19, 1988: June 2, 1988;
 June 2, 1988; June 2, 1988.

Replaces E59481C dated February 7, 1989. (Cont. on C1 card)
 262854001 N7047 Underwriters Laboratories Inc.® D11/0018965

AR-001A

