

SPECIFICATION FOR APPROVAL

REF :

PAGE: 1

PROD. NAME	SMD POWER INDUCTOR	ABC'S DWG NO. ABC'S ITEM NO.	SB5014□□□□L□-□□□
---------------	--------------------	---------------------------------	------------------

CONFIGURATION & DIMENSIONS :

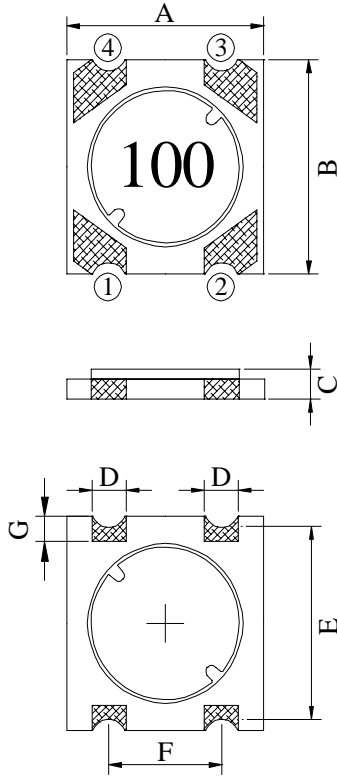

A	: 5.60 ±0.3	m/m
B	: 6.00 ±0.3	m/m
C	: 1.45 ±0.1	m/m
D	: 1.00 typ.	m/m
E	: 5.20 typ.	m/m
F	: 3.20 typ.	m/m
G	: 0.80 ref.	m/m
H	: 1.30 ref.	m/m
I	: 2.00 ref.	m/m
J	: 6.40 ref.	m/m
K	: 4.60 ref.	m/m
L	: 1.30 ref.	m/m
M	: 3.80 ref.	m/m

SCHEMATIC DIAGRAM :

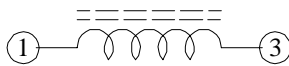

(PCB Pattern Suggestion)

MATERIALS :

- a . Core : Ferrite DR core
- b . Base : PCB Base FR4
- c . Adhesive : Epoxy resin
- d . Wire : Enamelled copper wire (class F)
- e . Terminal : Cu/Ni/Au
- f . Remark : Products comply with RoHS' requirements

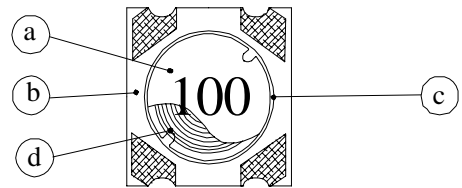

Peak Temp : 260 max.
 Max time above 230 : 50sec max.
 Max time above 200 : 70sec max.

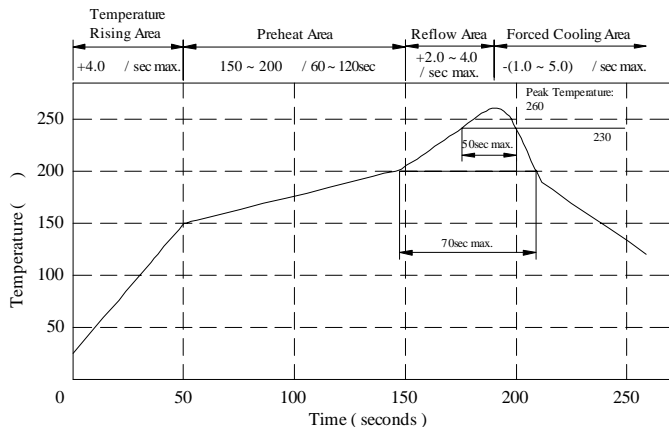

GENERAL SPECIFICATION :

- a . Temp. rise : 40 typ.
- b . Storage Temp. : -40 ----+125
- c . Operating Temp. : -40 ----+125
(Temp. rise Included)
- d . Resistance to solder heat : 260 .10 secs.

SPECIFICATION FOR APPROVAL

REF :

PAGE: 2

PROD. NAME	SMD POWER INDUCTOR	ABC'S DWG NO.	SB5014□□□□L□-□□□
		ABC'S ITEM NO.	

. ELECTRICAL CHARACTERISTICS :

DWG No.	Inductance (μH)	Test Freq. (Hz)	RDC (Ω) max.	Irms (A) typ.	Isat (A) typ.
SB50141R0ML□-□□□	1.0±20%	100K	0.032	2.50	2.80
SB50142R2ML□-□□□	2.2±20%	100K	0.058	1.80	2.10
SB50143R3ML□-□□□	3.3±20%	100K	0.078	1.60	1.72
SB50144R7ML□-□□□	4.7±20%	100K	0.105	1.20	1.40
SB50146R8ML□-□□□	6.8±20%	100K	0.150	1.05	1.15
SB5014100ML□-□□□	10.0±20%	100K	0.185	0.90	1.00
SB5014150ML□-□□□	15.0±20%	100K	0.300	0.65	0.80
SB5014220ML□-□□□	22.0±20%	100K	0.430	0.60	0.66
SB5014330ML□-□□□	33.0±20%	100K	0.625	0.45	0.53
SB5014470ML□-□□□	47.0±20%	100K	0.890	0.35	0.46
SB5014680ML□-□□□	68.0±20%	100K	1.250	0.30	0.35
SB5014101ML□-□□□	100.0±20%	100K	1.950	0.22	0.28

- 1). □ : Packaging information ... [A]: Bulk [B]: Taping Reel
- 2). "- □□□":Reference code
- 3).Inductance Test Freq : 100KHz / 1V
- 4). Irms Base on Temp. rise 40 typ.
Isat Bae on L/L0A=10 % typ.

@ Inductance VS. DC Superposition Characteristics

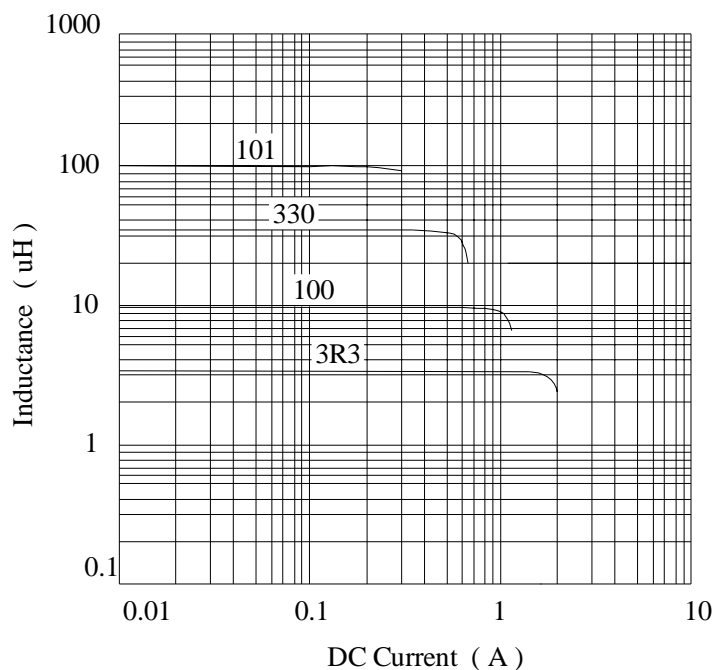

SPECIFICATION FOR APPROVAL

REF :

PAGE: 3

PROD. NAME	SMD POWER INDUCTOR	ABC'S DWG NO.	SB5014□□□□L□-□□□
		ABC'S ITEM NO.	

PACKAGING INFORMATION :

(1) Configuration

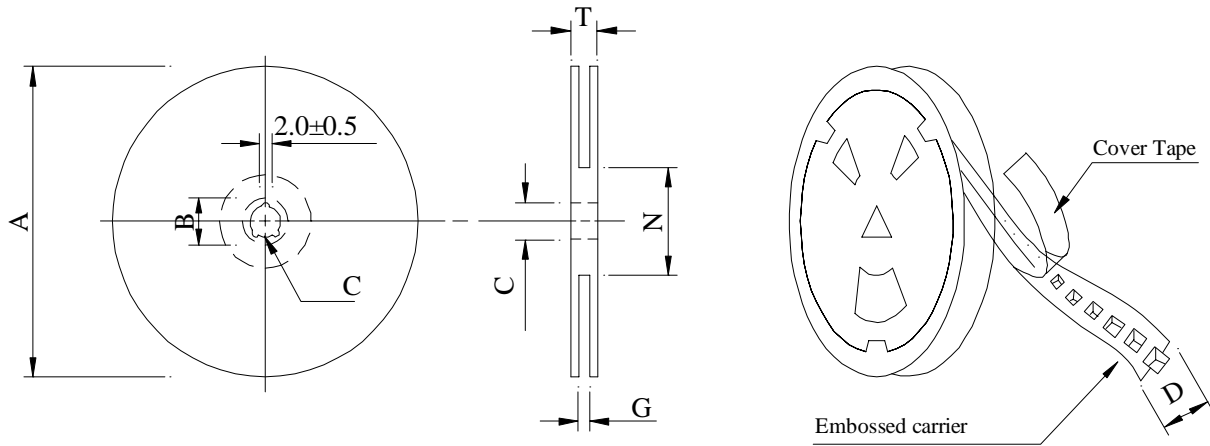

Carrier Tape width : D

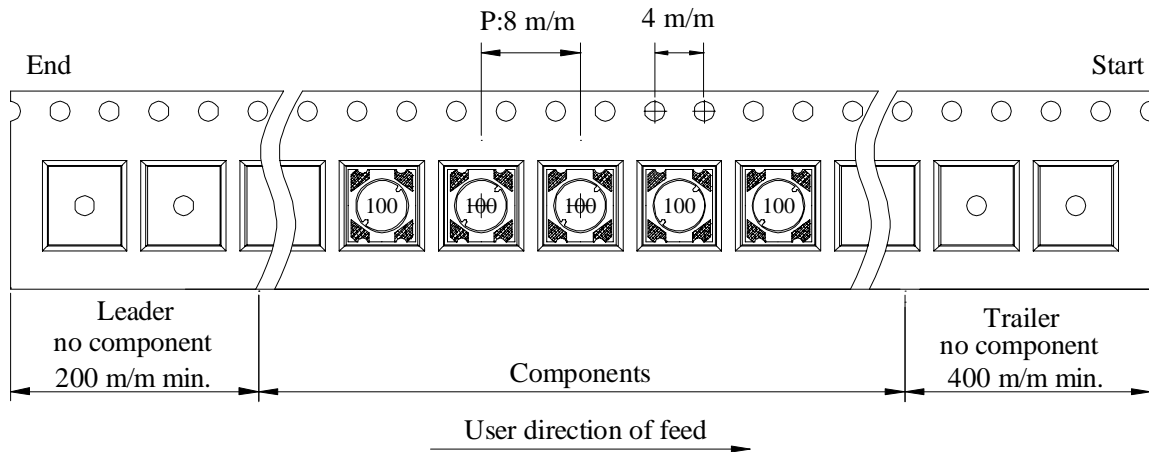

(2) Dimensions

Unit:m/m

Style	A	B	C	D	G	N	T
07-12	178	21±0.8	13	12	14 ⁺⁰	50 ⁻⁰	16.5

(3) Q'TY & G.W. Per package

Series	Inner : Reel			Outer : Carton		
	Q'TY (pcs)	G.W. (gw)	Style	Q'TY (pcs)	G.W. (Kg)	Size (cm)
SB5014	1000	120	07-12	40000	4.7	42 x 41 x 24

AR-001A

SPECIFICATION FOR APPROVAL

REF :

PAGE: 4

PROD. NAME	SMD POWER INDUCTOR	ABC'S DWG NO.	SB5014□□□□L□-□□□
		ABC'S ITEM NO.	

. DWGING NUMBER EXPRESSION :

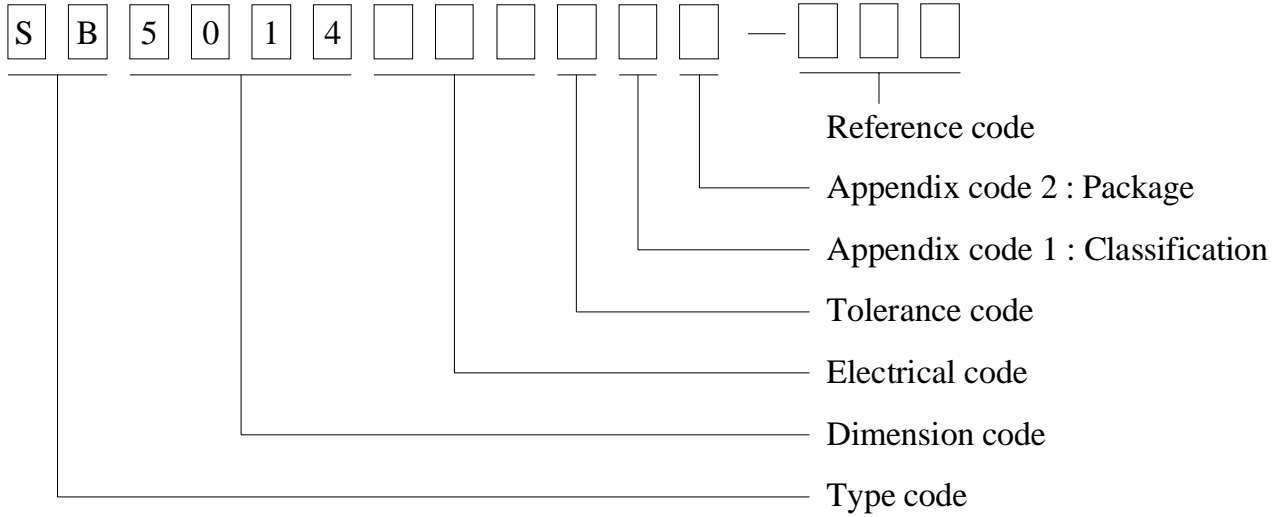

Appendix code 1 : Product Classification

- L : Lead Free Standard products comply with RoHS' requirements
- 1 ~ 9 : Lead Free Special products comply with RoHS' requirements

Appendix code 2 : Package Information

Code	Inner package	Inner package Q'TY	Remark
A	T.B.D.	T.B.D.	
B	T / R (Reel package)	1000 pcs	

SPECIFICATION FOR APPROVAL

REF :

PAGE: 5

PROD. NAME	SMD POWER INDUCTOR	ABC'S DWG NO.	SB5014□□□□L□-□□□
		ABC'S ITEM NO.	

. RELIABILITY TEST :

Test item	Specification	Test condition															
Solderability	More than 90% of the terminal electrode shall be covered With fresh solder.	Preheat : 150±25 for 60 seconds Solder : Sn96.5 / Ag3 / Cu0.5 or equivalent Solder temp. : 235±5 Flux : Rosin Dip time : 4±1 seconds															
Thermal shock test (Temp. cycle)	Inductance shall not change more than ±20%	<table style="width: 100%; border: none;"> <tr> <td style="text-align: center;">Room temp.</td> <td style="text-align: center;">—————▶</td> <td style="text-align: center;">-25±2</td> </tr> <tr> <td style="text-align: center;">15 minutes</td> <td></td> <td style="text-align: center;">30 minutes</td> </tr> <tr> <td colspan="3" style="padding: 10px 0 0 0;"> </td> </tr> <tr> <td style="text-align: center;">Room temp.</td> <td style="text-align: center;">—————▶</td> <td style="text-align: center;">85±2</td> </tr> <tr> <td style="text-align: center;">15 minutes</td> <td></td> <td style="text-align: center;">30 minutes</td> </tr> </table> <p>Total : 50 cycles</p>	Room temp.	—————▶	-25±2	15 minutes		30 minutes				Room temp.	—————▶	85±2	15 minutes		30 minutes
Room temp.	—————▶	-25±2															
15 minutes		30 minutes															
Room temp.	—————▶	85±2															
15 minutes		30 minutes															
Humidity Resistance test		Temperature : 40±2 Humidity : 90 ~ 95% Applied current : Per spec. Time : 500 hours															
High temp. Resistance test		Temperature : 85±2 Applied current : Per spec. Time : 500 hours															

AR-001A



SPECIFICATION FOR APPROVAL

REF :

PAGE: 6

PROD. NAME	SMD POWER INDUCTOR	ABC'S DWG NO.	SB5014□□□□L□-□□□
		ABC'S ITEM NO.	

UL CARD :

OBMW2 September 8, 2000

Magnet Wire-Component

JUNG SHING WIRE CO LTD E174837

231 CHUNG CHENG RD, SEC 3 JEN-TEH HSIANG, TAINAN

HSIEN TAIWAN

Mtl Dsg	Mark Dsg	BC	Coat Typ	OC	ANSI Type	Temp Class
AIW	---	Polyamideimide	---	---	MW81-C	220
CFUEWB	---	Polyurethane	---	---	MW75C	130
EIAIW	---	Polyesterimide	Polyamideimide	---	MW35C	200
EILOCKY	---	Polyesterimide	Polyamide	---	---	180
EILOCKW	---	Polyesterimide	Modified Epoxy	---	---	200
EIW	---	Polyesterimide	---	---	---	220
EIW-2	---	Polyesterimide	---	---	MW74-C	200
FL.EILOCKY	---	Modified Polyester	Polyamide	---	---	155
LSFFW	---	Polyurethane	---	---	MW79-C	155
LSUEW	---	Polyurethane	---	---	---	130
PEW	---	Polyester	---	---	---	155
PEY	---	Polyester	Nylon	---	MW24-C	155
SF.FLW	---	Modified Polyester	---	---	MW26C	155
SF.EIW	---	Polyesterimide	---	---	MW77C	180
SF.BY@	---	Modified Polyester	Nylon	---	MW27-C	155
SF.FLY@	---	Modified Polyester	Nylon	---	MW27-C	155
SF.BLOCKBS	---	Modified Polyester	Modified Polyamide	---	---	155
SF.EILOCKY#	---	Polyesterimide	Polyamide	---	---	180
SF.EILOCKBS	---	Polyesterimide	Modified Polyamide	---	---	180
SF.BW@	---	Modified Polyester	---	---	MW26C	155
SFFW	---	Polyurethane	---	---	MW79	155

287806002 Page 1 of 2

A not-for-profit organization
dedicated to public safety and
committed to quality service

Mtl Dsg	Mark Dsg	BC	Coat Typ	OC	ANSI Type	Temp Class
SFFY	---	Polyurethane	Polyamide	---	MW80C	155
UEW-1	---	Polyurethane	---	---	MW2-C	105
UEW-2	---	Polyurethane	---	---	---	130
UEW-4	---	Polyurethane	---	---	MW75C	130
UEY	---	Polyurethane	Nylon	---	MW28-C	130
UEY-2	---	Polyurethane	Polyamide	---	MW28-C	130

@ - May be suffixed by LZ; # - May be suffixed by LZ, EL or LZL.
LZ - Signifies magnet wires twisted together; EL - signifies base coated magnet wire laid parallel with top coat applied overall; LZL - signifies base coated magnet wire twisted together and covered with top coat overall.

Marking: Company name or trademarks (JSW) or 榮星電線, material designation or marked designation on packaed or reel, and Recognized Component Mark.

See General Information Preceding These Recognitions
For use only in equipment where the acceptability of the combination is determined by Underwriters Laboratories Inc.

287806002 Page 2 of 2

OBMW2/E174837
September 8, 2000

SPECIFICATION FOR APPROVAL

REF :

PAGE: 7

PROD. NAME	SMD POWER INDUCTOR	ABC'S DWG NO.	SB5014□□□□L□-□□□
		ABC'S ITEM NO.	

QMTS2 September 20, 2000

Polymeric Materials-Filament-wound Tubing. Industrial Laminates. Vulcanized Fiber, and Materials for Use in Fabricating Recognized Printed Wiring Boards - Component

TAIWAN LEADER COPPER CLAD LAMINATE CO LTD E176891

Clad Mil Deg	Base Mtl ANSI Type	Min Thick		Clad Cond Thick		Max Area Dia In. (mm)	Soldering		UL94 Flame Class	Max Oper Temp			
		In. (mm)	Mils (Mks)	Min	Max		Temp C	Time Sec					
Metal clad industrial laminates for use in printed wiring boards, furnished in the form of sheets with copper cladding on one or both sides.													
JL-180L	FR-5	0.025	(0.63)	0.67	(17)	2.68	(68)	2.0	(50.8)	300	30	94V-0	140
LS-4	FR-4	0.015	(0.38)	0.68	(17)	2.68	(68)	2.0	(50.8)	280	30	94V-0	130
		0.015	(0.38)	0.68	(17)	2.68	(68)	1.5	(38.1)	288	30	94V-0	130
LS-4Y	FR-4	0.015	(0.38)	0.67	(17)	2.68	(68)	2.0	(50.8)	288	30	94V-0	130

3/7/2001 Underwriters Laboratories Inc.®

AR-001A

