

SPECIFICATION FOR APPROVAL

REF :

PAGE: 1

PROD. NAME	SMD POWER INDUCTOR	ABC'S DWG NO.	SB5023□□□□L□-□□□
		ABC'S ITEM NO.	

I . CONFIGURATION & DIMENSIONS :

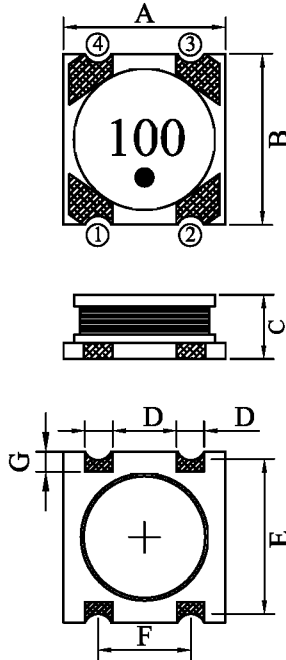

A	: 5.60 ±0.3	m/m
B	: 6.00 ±0.3	m/m
C	: 2.50 ±0.2	m/m
D	: 1.00 typ.	m/m
E	: 5.20 typ.	m/m
F	: 3.20 typ.	m/m
G	: 0.80 ref.	m/m
H	: 1.30 ref.	m/m
I	: 2.00 ref.	m/m
J	: 6.40 ref.	m/m
K	: 4.60 ref.	m/m
L	: 1.30 ref.	m/m
M	: 3.80 ref.	m/m

(PCB Pattern Suggestion)

(Test method)
(2R2~470)

II . SCHEMATIC DIAGRAM :

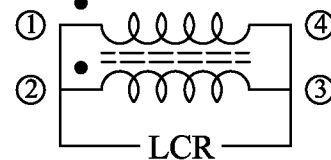
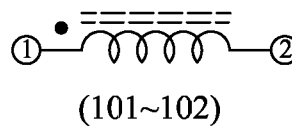
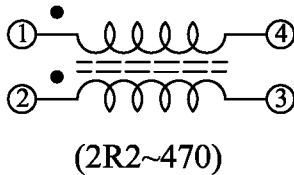

III . MATERIALS :

- a . Core : Ferrite DR core
- b . Base : PCB Base FR4
- c . Adhesive : Epoxy resin
- d . Wire : Enamelled copper wire (class F)
- e . Terminal : Cu/Ni/Au
- f . Remark : Products comply with RoHS' requirements

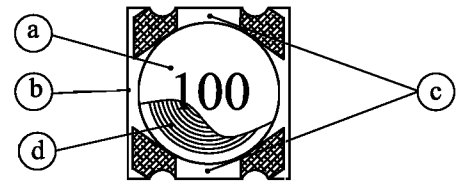

Peak Temp : 260°C max.
Max time above 230°C : 50sec max.
Max time above 200°C : 70sec max.

IV . GENERAL SPECIFICATION :

- a . Storage Temp. : -40°C ----+125°C
- b . Operating Temp. : -40°C ----+125°C
(Temp. rise Included)
- c . Resistance to solder heat : 260°C.10 secs.

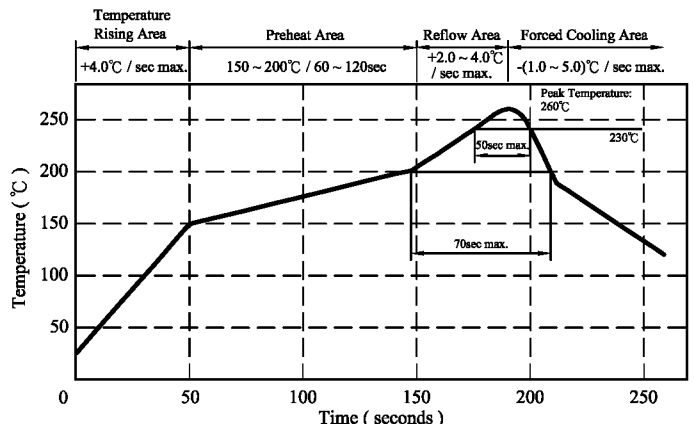

AR-001A

SPECIFICATION FOR APPROVAL

REF :

PAGE: 2

PROD. NAME	SMD POWER INDUCTOR	ABC'S DWG NO.	SB5023□□□□L□-□□□
		ABC'S ITEM NO.	

V . ELECTRICAL CHARACTERISTICS :

DWG NO.	INDUCTANCE (μ H)	TEST FREQ. (Hz)	RDC(Ω) max./typ.	Irms (mA) max	Isat (mA) typ
SB50232R2YL□-□□□	2.2 \pm 25%	100K	0.036 / 0.028	2200	2300
SB50233R3YL□-□□□	3.3 \pm 25%	100K	0.056 / 0.042	1750	1900
SB50234R7YL□-□□□	4.7 \pm 25%	100K	0.073 / 0.056	1550	1600
SB5023100YL□-□□□	10.0 \pm 25%	100K	0.136 / 0.105	1300	1150
SB5023220YL□-□□□	22.0 \pm 25%	100K	0.300 / 0.230	800	750
SB5023470YL□-□□□	47.0 \pm 25%	100K	0.620 / 0.480	520	500
SB5023101YL□-□□□	100.0 \pm 15%	100K	1.100 / 0.900	350	360
SB5023221YL□-□□□	220.0 \pm 15%	100K	2.400 / 2.000	270	250
SB5023471YL□-□□□	470.0 \pm 15%	100K	5.500 / 4.600	180	160
SB5023102YL□-□□□	1000.0 \pm 15%	100K	13.50 / 11.50	100	85

- 1). □ : Packaging information ... **[A]** : Bulk **[B]** : Taping Reel
- 2). "- □□□ " : Reference code
- 3). Inductance Test Freq : 100KHz / 1V
- 4). I rms Base on Temp. rise 40°C max.
Isat Base on $\Delta L/L0A=10\%$ typ.

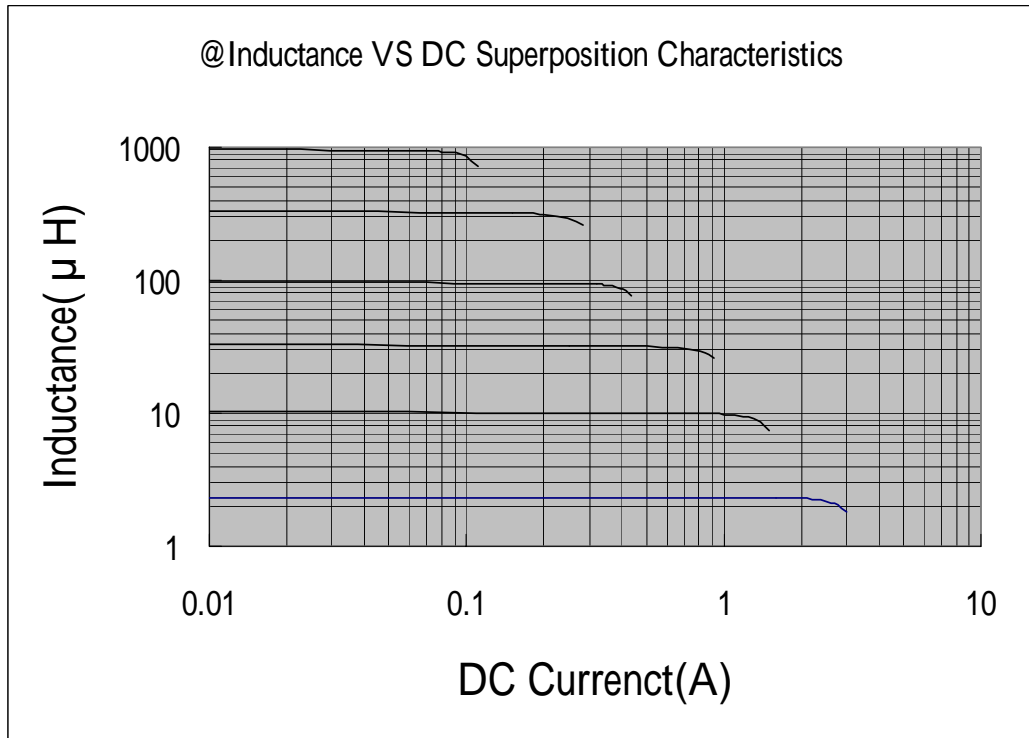

SPECIFICATION FOR APPROVAL

REF :

PAGE: 3

PROD. NAME	SMD POWER INDUCTOR	ABC'S DWG NO.	SB5023□□□□L□-□□□
		ABC'S ITEM NO.	

VI . PACKAGING INFORMATION :

(1) Configuration

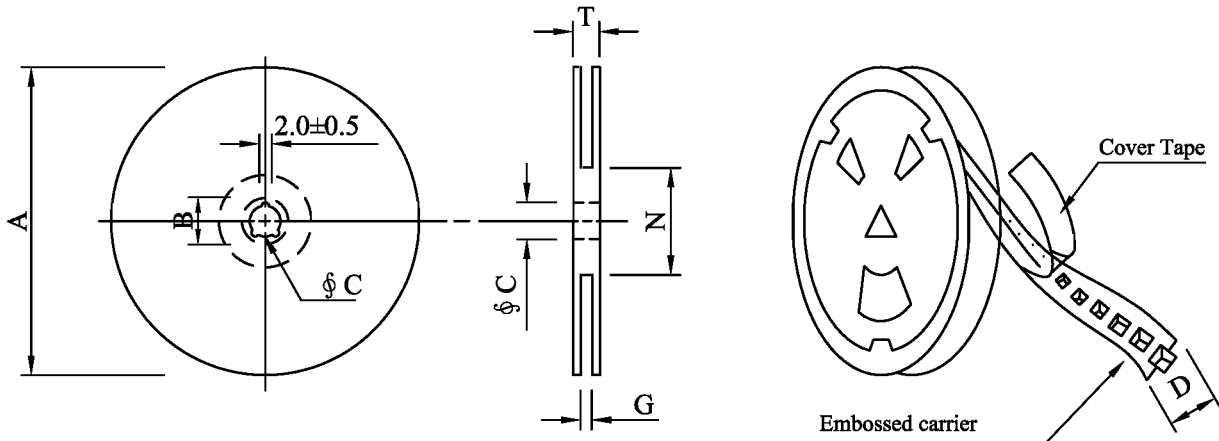

※Carrier Tape width : D

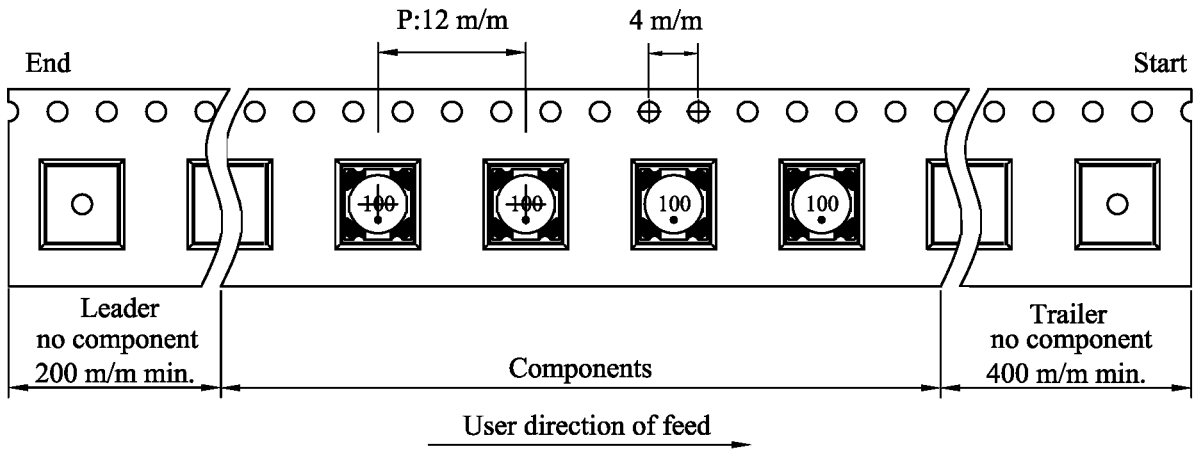

(2) Dimensions

Unit:m/m

Style	A	B	C	D	G	N	T
07-16	178	21±0.8	13	16	18 ⁺⁰	50 ⁻⁰	20.5

(3) Q'TY & G.W. Per package

Series	Inner : Reel			Outer : Carton		
	Q'TY (pcs)	G.W. (gw)	Style	Q'TY (pcs)	G.W. (Kg)	Size (cm)
SB5023	400	600	07-16	12000	6.00	42 x 41 x 24

SPECIFICATION FOR APPROVAL

REF :

PAGE: 4

PROD. NAME	SMD POWER INDUCTOR	ABC'S DWG NO.	SB5023□□□□L□-□□□
		ABC'S ITEM NO.	

VII . DWGING NUMBER EXPRESSION :

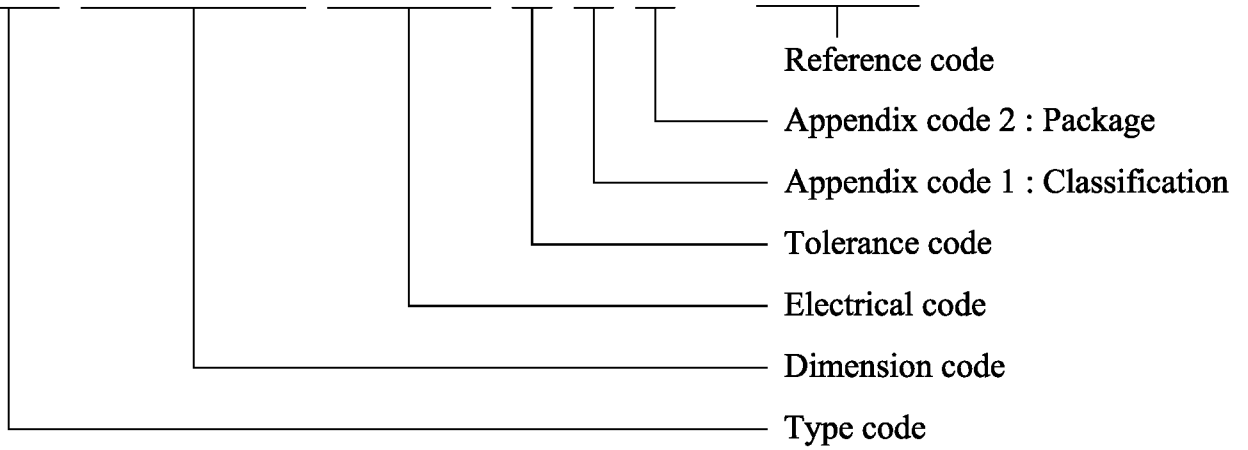
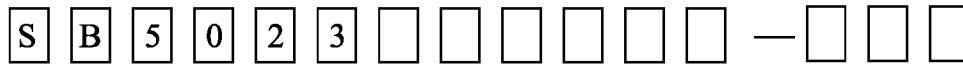

Appendix code 1 : Product Classification

- L : Lead Free Standard products comply with RoHS' requirements
- 1 ~ 9 : Lead Free Special products comply with RoHS' requirements

Appendix code 2 : Package Information

Code	Inner package	Inner package Q'TY	Remark
A	T.B.D.	T.B.D.	
B	T / R (Reel package)	400 pcs	

AR-001A



SPECIFICATION FOR APPROVAL

REF :

PAGE: 5

PROD. NAME	SMD POWER INDUCTOR	ABC'S DWG NO.	SB5023□□□□L□-□□□
		ABC'S ITEM NO.	

VIII . RELIABILITY TEST :

Test item	Specification	Test condition						
Solderability	More than 90% of the terminal electrode shall be covered With fresh solder.	Preheat : 150±25°C for 60 seconds Solder : Sn96.5 / Ag3 / Cu0.5 or equivalent Solder temp. : 235±5°C Flux : Rosin Dip time : 4±1 seconds						
Thermal shock test (Temp. cycle)	Inductance shall not change more than ±20%	<table style="width: 100%; border: none;"> <tr> <td style="text-align: center;">Room temp. 15 minutes</td> <td style="text-align: center;">→</td> <td style="text-align: center;">-25±2 °C 30 minutes</td> </tr> <tr> <td style="text-align: center;">Room temp. 15 minutes</td> <td style="text-align: center;">→</td> <td style="text-align: center;">85±2 °C 30 minutes</td> </tr> </table> <p>Total : 50 cycles</p>	Room temp. 15 minutes	→	-25±2 °C 30 minutes	Room temp. 15 minutes	→	85±2 °C 30 minutes
Room temp. 15 minutes		→	-25±2 °C 30 minutes					
Room temp. 15 minutes		→	85±2 °C 30 minutes					
Humidity Resistance test		Temperature : 40±2°C Humidity : 90 ~ 95% Applied current : Per spec. Time : 500 hours						
High temp. Resistance test	Temperature : 85±2°C Applied current : Per spec. Time : 500 hours							

SPECIFICATION FOR APPROVAL

REF :

PAGE: 6

PROD. NAME	SMD POWER INDUCTOR	ABC'S DWG NO.	SB5023□□□□L□-□□□
		ABC'S ITEM NO.	

IX . UL CARD :

OBMW2 September 8, 2000

Magnet Wire-Component

JUNG SHING WIRE CO LTD E174837

231 CHUNG CHENG RD, SEC 3 JEN-TEH HSIANG, TAINAN
HSIEN TAIWAN

Mtl Dsg	Mark Dsg	BC	Coat Typ	OC	ANSI Type	Temp Class
AIW	---	Polyamideimide		---	MW81-C	220
CFUEWB	---	Polyurethane		---	MW75C	130
EIAIW	---	Polyesterimide		Polyamideimide	MW35C	200
EILOCKY	---	Polyesterimide		Polyamide	---	180
EILOCKW	---	Polyesterimide		Modified Epoxy	---	200
EIW	---	Polyesterimide		---	---	220
EIW-2	---	Polyesterimide		---	MW74-C	200
FL.EILOCKY	---	Modified Polyester		Polyamide	---	155
LSFFW	---	Polyurethane		---	MW79-C	155
LSUEW	---	Polyurethane		---	---	130
PEW	---	Polyester		---	---	155
PEY	---	Polyester		Nylon	MW24-C	155
SF.FLW	---	Modified Polyester		---	MW26C	155
SF.EIW	---	Polyesterimide		---	MW77C	180
SF.BY@	---	Modified Polyester		Nylon	MW27-C	155
SF.FLY@	---	Modified Polyester		Nylon	MW27-C	155
SF.BLOCKBS	---	Modified Polyester		Modified Polyamide	---	155
SF.EILOCKY#	---	Polyesterimide		Polyamide	---	180
SF.EILOCKBS	---	Polyesterimide		Modified Polyamide	---	180
SF.BW@	---	Modified Polyester		---	MW26C	155
SFFW	---	Polyurethane		---	MW79	155

287806002 Page 1 of 2

A not-for-profit organization
dedicated to public safety and
committed to quality service

Mtl Dsg	Mark Dsg	BC	Coat Typ	OC	ANSI Type	Temp Class
SFFY	---	Polyurethane		Polyamide	MW80C	155
UEW-1	---	Polyurethane		---	MW2-C	105
UEW-2	---	Polyurethane		---	---	130
UEW-4	---	Polyurethane		---	MW75C	130
UEY	---	Polyurethane		Nylon	MW28-C	130
UEY-2	---	Polyurethane		Polyamide	MW28-C	130

@-May be suffixed by LZ; # - May be suffixed by LZ, EL or LZI.
LZ - Signifies magnd wires twisted together; EL - signifies base coated magnet wire laid parallel with top coat applied overall; LZL - signi-
fies base coated magnet wire twisted together and covered with top coat overall.

Marking: Company name or trademarks **JSW** or 榮星電線 , material designation or marked designation on packaed or reel, and
Recognized Component Mark.

See General Information Preceding These Recognitions
For use only in equipment where the acceptability of the combination is determined by Underwriters Laboratories Inc.

287806002 Page 2 of 2

OBMW2/E174837
September 8 , 2000

SPECIFICATION FOR APPROVAL

REF :

PAGE: 7

PROD. NAME	SMD POWER INDUCTOR	ABC'S DWG NO.	SB5023□□□□L□-□□□
		ABC'S ITEM NO.	

QMTS2 September 20, 2000

Polymeric Materials-Filament-wound Tubing, Industrial Laminates, Vulcanized Fiber, and Materials for Use in Fabricating Recognized Printed Wiring Boards - Component

TAIWAN LEADER COPPER CLAD LAMINATE CO LTD E176891

Clad Mil Deg	Base Mtl ANSI Type	Min Thick		Clad Cond Thick		Max Area Dia		Soldering		UL94 Flame Class	Max Oper Temp	
		In. (mm)	(mm)	Min Mils (Mks)	Max Mils (Mks)	In. (mm)	(mm)	Temp C	Time Sec			
Metal clad industrial laminates for use in printed wiring boards, furnished in the form of sheets with copper cladding on one or both sides.												
JL-180L	FR-5	0.025	(0.63)	0.67	(17)	2.68	(68)	2.0	(50.8)	300	30	94V-0 140
LS-4	FR-4	0.015	(0.38)	0.68	(17)	2.68	(68)	2.0	(50.8)	280	30	94V-0 130
		0.015	(0.38)	0.68	(17)	2.68	(68)	1.5	(38.1)	288	30	94V-0 130
LS-4Y	FR-4	0.015	(0.38)	0.67	(17)	2.68	(68)	2.0	(50.8)	288	30	94V-0 130

3/7/2001 Underwriters Laboratories Inc.®