

SPECIFICATION FOR APPROVAL

REF :

PAGE: 1

PROD. NAME	SHIELDED SMD POWER INDUCTOR	ABC'S DWG No.	SP1055□□□□2□
		ABC'S ITEM No.	

I . MECHANICAL DIMENSIONS :

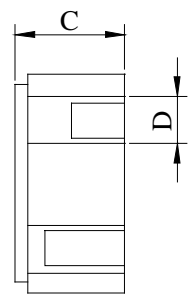
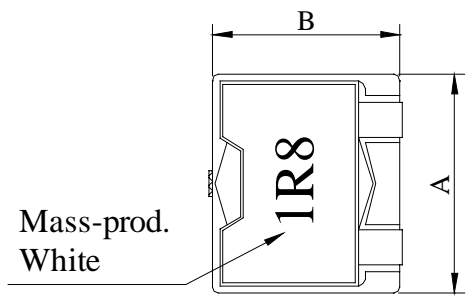

- A : 11.00±0.30 m/m
- B : 9.35±0.30 m/m
- C : 5.50±0.30 m/m
- D : 2.10 typ. m/m
- E : 2.00 typ. m/m
- E1: 1.00 typ. m/m
- E2: 1.50 typ. m/m
- F : 6.00 typ. m/m

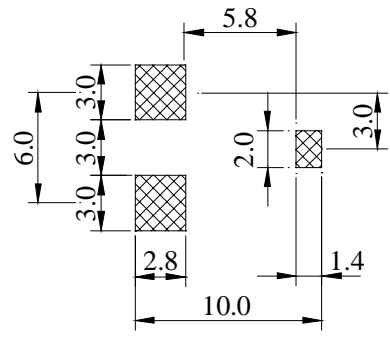
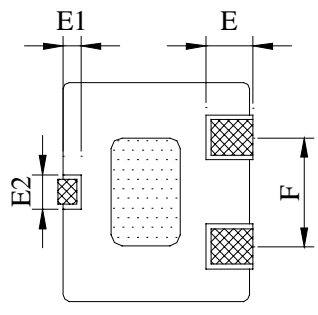

II . SCHEMATIC DIAGRAM :

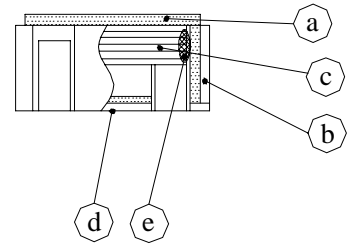
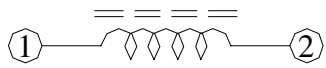

III . MATERIALS LIST :

- a . Core : Ferrite ER core
- b . Base : UL 94V-0
- c . Wire : Ultra-fine rectangular
Enamelled copper wire
- d . Clip : Cu / Ni / Sn
- e . Adhesive : Epoxy resin
- f . Remark : Lead content 200ppm max.
include ferrite

Peak Temp : 260°C max.
Max time above 230°C : 50sec max.
Max time above 200°C : 70sec max.

IV . GENERAL SPECIFICATION :

- a . Storage temp. : -55°C ~ +135°C
- b . Operating temp. : -55°C ~ +135°C
(Temp. rise included)
- c . Resistance to solder heat : 260°C. 10 secs.

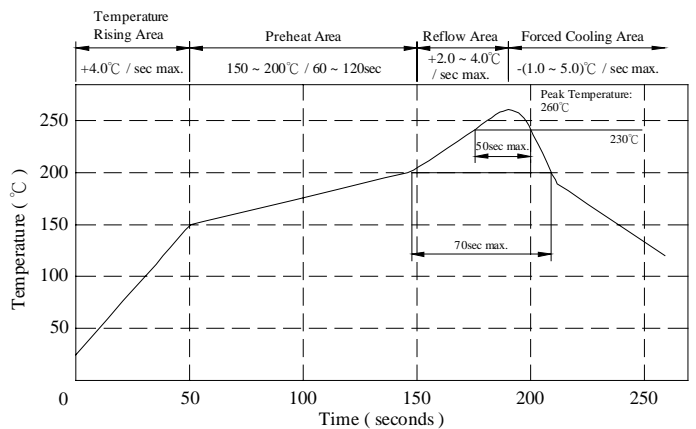

AE-001A

SPECIFICATION FOR APPROVAL

REF :

PAGE: 2

PROD. NAME	SHIELDED SMD POWER INDUCTOR	ABC'S DWG No.	SP1055□ □ □ □ 2□
		ABC'S ITEM No.	

V . ELECTRICAL CHARACTERISTICS :

DWG No.	Inductance L (μ H)	Isat (A)	Irms (A)	RDC ($m\Omega$)	
				max.	typ.
SP1055R22Y2□	0.22 \pm 30 %	42.0	25.0	1.7	1.3
SP1055R45M2□	0.45 \pm 20 %	30.0	20.0	2.5	1.9
SP1055R80M2□	0.80 \pm 20 %	22.0	16.0	3.2	2.4
SP10551R3M2□	1.30 \pm 20 %	18.0	12.0	5.8	4.7
SP10551R8M2□	1.80 \pm 20 %	16.0	10.0	7.2	5.6
SP10552R5M2□	2.50 \pm 20 %	13.5	8.5	8.5	6.5
SP10553R2M2□	3.20 \pm 20 %	11.5	7.2	13.2	10.7
SP10554R0M2□	4.00 \pm 20 %	10.0	6.2	15.5	11.9
SP10555R0M2□	5.00 \pm 20 %	8.6	5.8	17.2	13.2

- 1). □ : Packaging information ... [A]: Bulk [B]: Taping Reel
 2). Measured frequency of inductance is 100 KHz / 1V
 3). Isat base on inductance drop 25% typ. of L value at 20°C
 4). Irms base on temp. rise 40°C max.

SPECIFICATION FOR APPROVAL

REF :

PAGE: 3

PROD. NAME	SHIELDED SMD POWER INDUCTOR	ABC'S DWG No. ABC'S ITEM No.	SP1055□ □ □ □ 2□
---------------	--------------------------------	---------------------------------	------------------

@ Inductance VS. DC Superposition characteristics

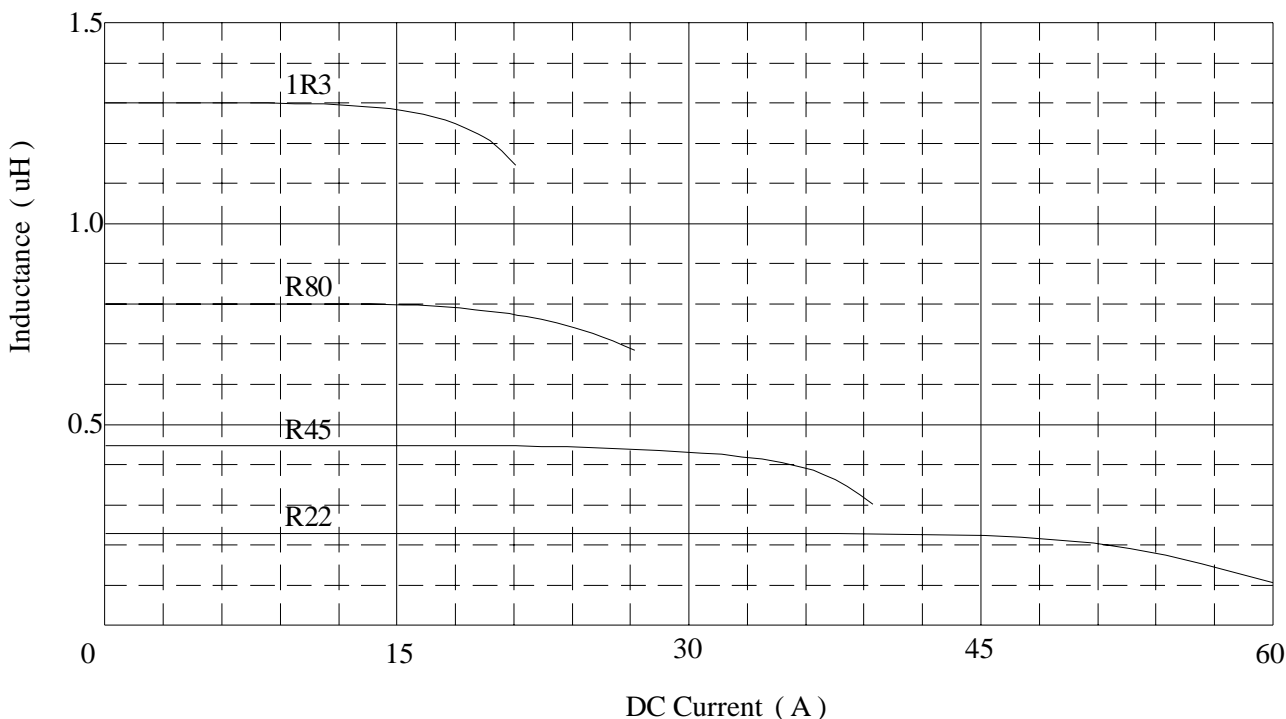
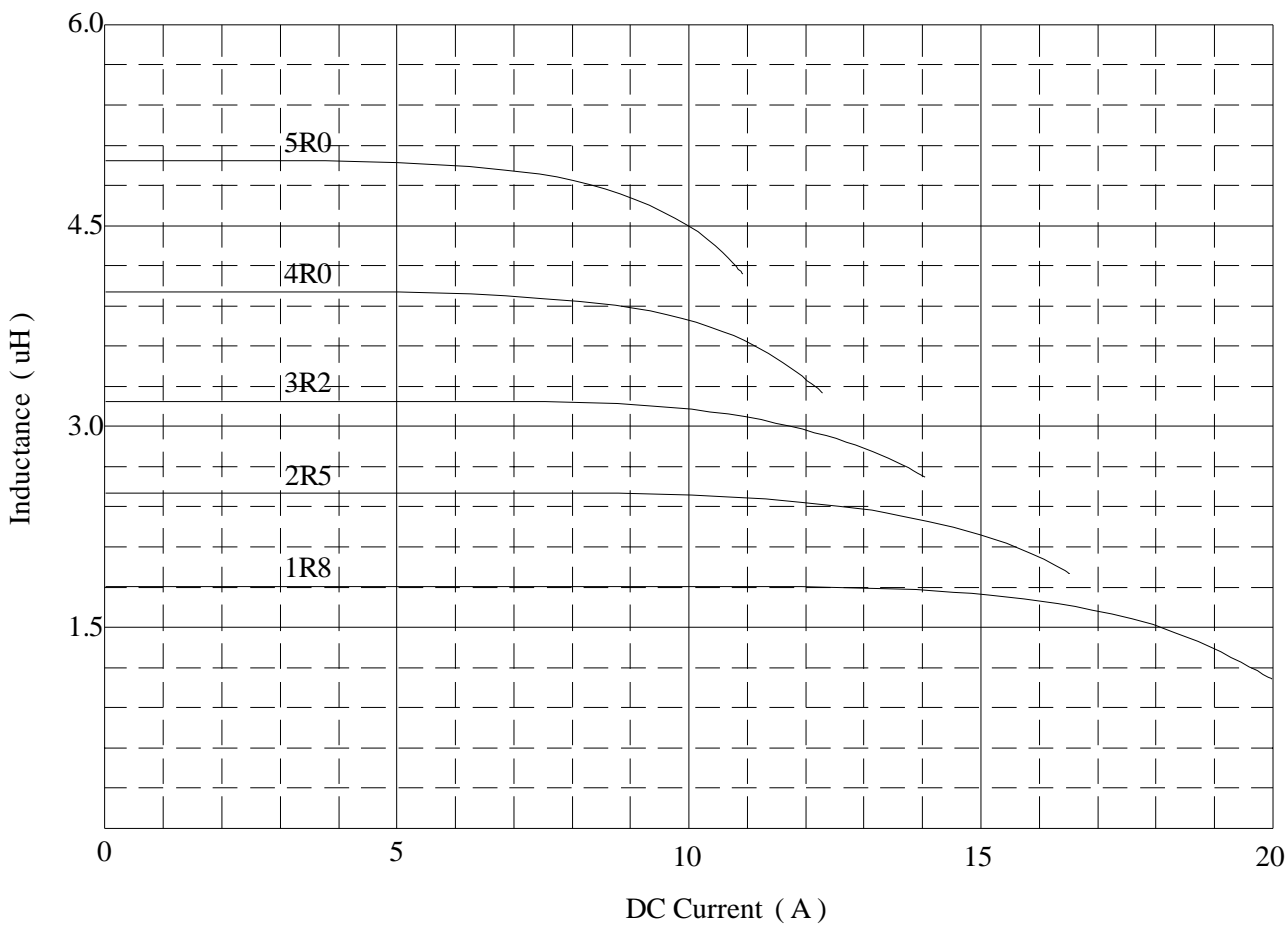

SPECIFICATION FOR APPROVAL

REF :

PAGE: 4

PROD. NAME	SHIELDED SMD	ABC'S DWG No.	SP1055□ □ □ □ 2□
	POWER INDUCTOR	ABC'S ITEM No.	

@ DC Current VS Temperature Rise

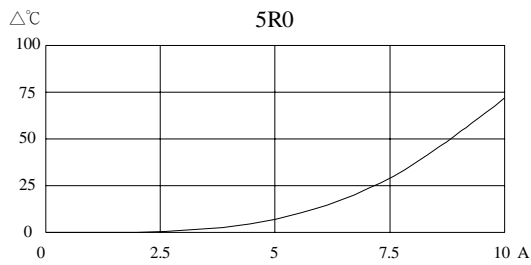
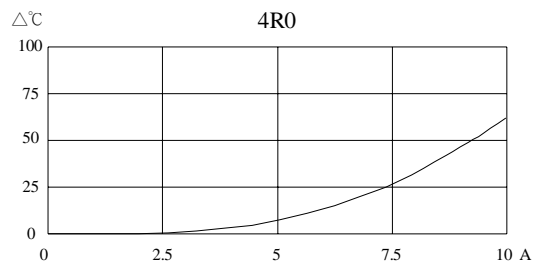
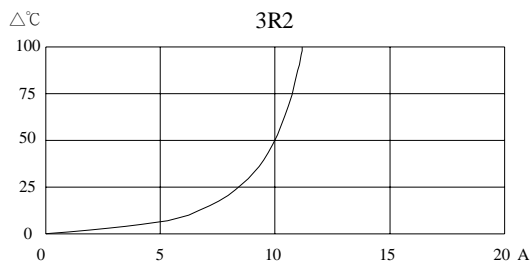
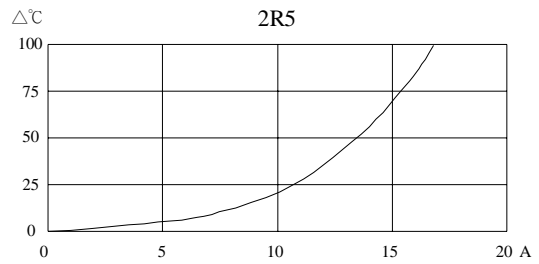
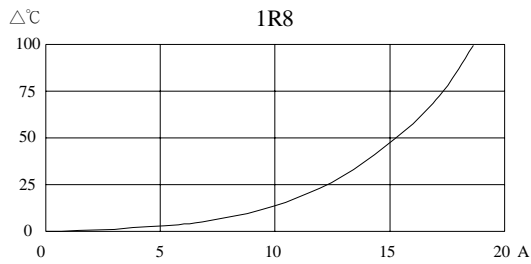
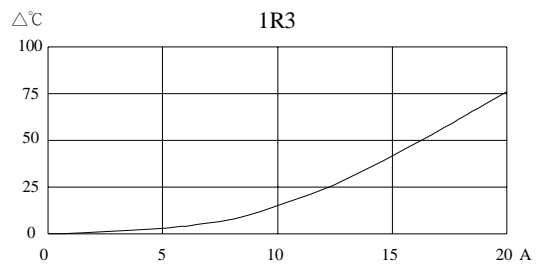
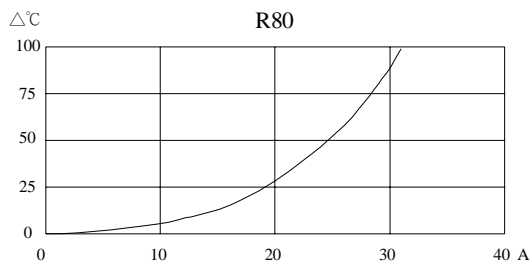
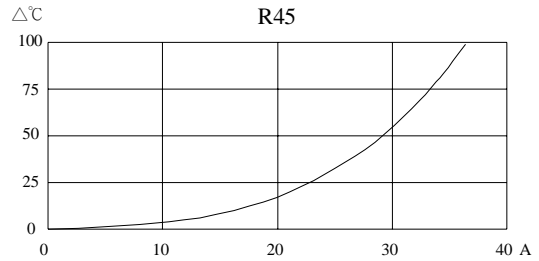
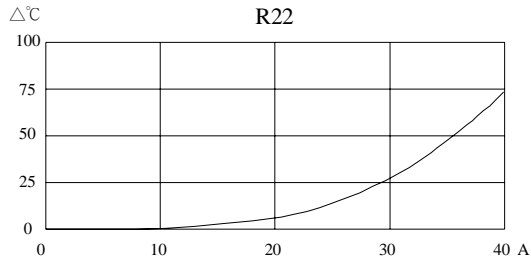

AE-001A

SPECIFICATION FOR APPROVAL

REF :

PAGE: 5

PROD. NAME	SHIELDED SMD POWER INDUCTOR	ABC'S DWG No.	SP1055□ □ □ □ 2□
		ABC'S ITEM No.	

VII . PACKAGING INFORMATION :

(1) Configuration

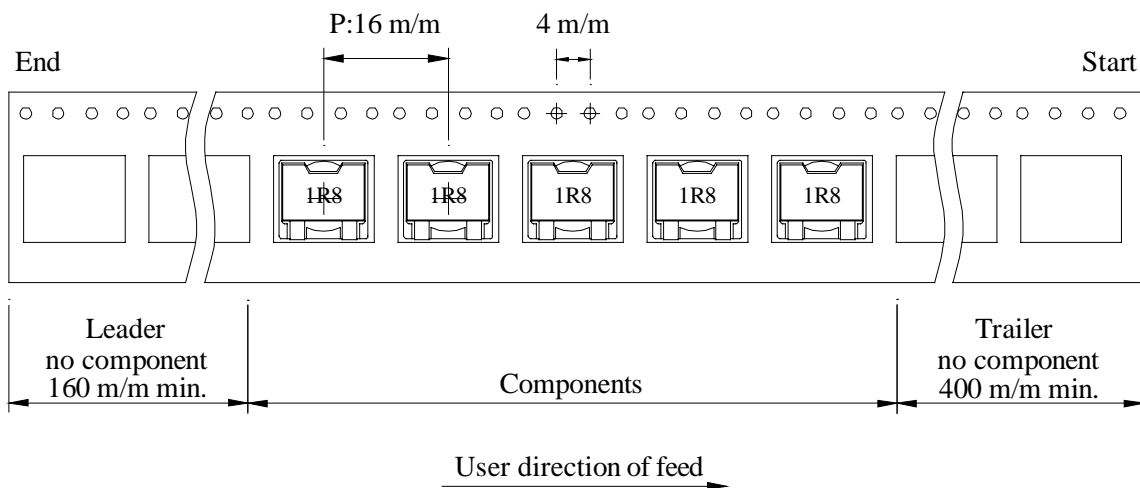
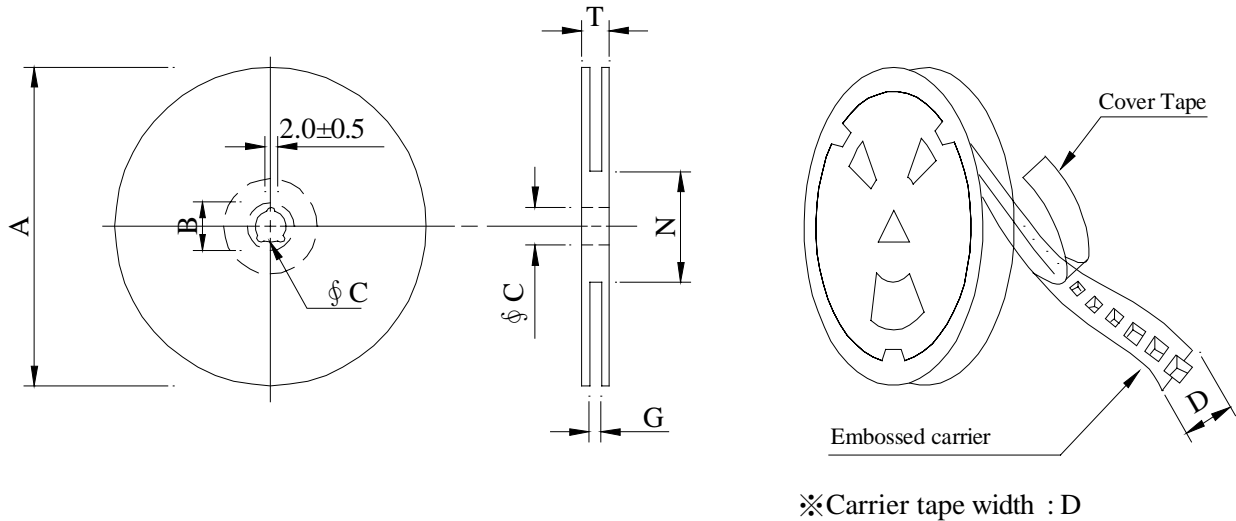

(2) Dimensions

Unit:m/m

Style	A	B	C	D	G	N	T
13 - 24	330	21±0.8	13±0.5	24	26 ⁺⁰	50 ⁻⁰	30.4

(3) Q'TY & G.W. Per package

Series	Inner : Reel			Outer : Carton		
	Q'TY (pcs)	G.W. (gw)	Style	Q'TY (pcs)	G.W. (Kg)	Size (cm)
SP1055	600	700	13 - 24	2,400	6.50	40 x 40 x 24

SPECIFICATION FOR APPROVAL

REF :

PAGE: 6

PROD. NAME	SHIELDED SMD POWER INDUCTOR	ABC'S DWG No. ABC'S ITEM No.	SP1055□ □ □ □ 2□
---------------	--------------------------------	---------------------------------	------------------

VII . DWG EXPRESSION :

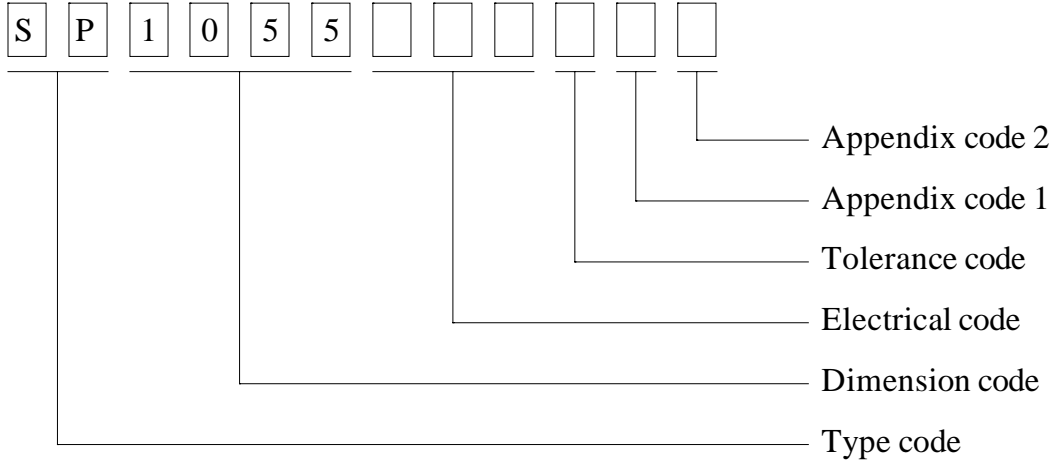

- Appendix code 1 : S : Standard products
- A~K , M~R , T~Z : Special products
- L : Standard Lead Free products
- 1 ~ 9 : Special Lead Free products

Appendix code 2 :

Code	Inner package	Inner package Q'TY	Remark
A	Empty	Empty	
B	T / R (Reel package)	600 pcs	

SPECIFICATION FOR APPROVAL

REF :

PAGE: 7

PROD. NAME	SHIELDED SMD POWER INDUCTOR	ABC'S DWG No.	SP1055□ □ □ □ 2□
		ABC'S ITEM No.	

VIII . RELIABILITY TEST :

Test item	Specification	Test condition												
Solderability	More than 90% of the terminal electrode Shall be covered With fresh solder.	Preheat : 150± 25°C for 60 seconds Solder : Sn96.5 / Ag3 / Cu0.5 or equivalent Solder temp. : 250± 5°C Flux : Rosin Dip time : 4±1 seconds												
Thermal shock test (Temp. cycle)	Inductance shall not change more than ±20%	<table style="width: 100%; border: none;"> <tr> <td style="text-align: center;">Room temp.</td> <td style="text-align: center;">—————▶</td> <td style="text-align: center;">-25± 2°C</td> </tr> <tr> <td style="text-align: center;">15 minutes</td> <td></td> <td style="text-align: center;">30 minutes</td> </tr> <tr> <td style="text-align: center;">Room temp.</td> <td style="text-align: center;">—————▶</td> <td style="text-align: center;">85± 2°C</td> </tr> <tr> <td style="text-align: center;">15 minutes</td> <td></td> <td style="text-align: center;">30 minutes</td> </tr> </table> <p>Total : 50 cycles</p>	Room temp.	—————▶	-25± 2°C	15 minutes		30 minutes	Room temp.	—————▶	85± 2°C	15 minutes		30 minutes
Room temp.		—————▶	-25± 2°C											
15 minutes			30 minutes											
Room temp.		—————▶	85± 2°C											
15 minutes		30 minutes												
Humidity Resistance test	Temperature : 40± 2°C Humidity : 90 ~ 95% Applied current : Per spec. Time : 500 hours													
High temp. Resistance test	Temperature : 85± 2°C Applied current : Per spec. Time : 500 hours													

SPECIFICATION FOR APPROVAL

REF :

PAGE: 8

PROD. NAME	SHIELDED SMD POWER INDUCTOR	ABC'S DWG No.	SP1055□ □ □ □ 2□
		ABC'S ITEM No.	

IX . UL CARD :

OBMW2	January 7, 1988	
Component-Magnet Wire		E104048 (S)
MITSUBISHI CABLE INDUSTRIES LTD		
4-3 IKEJIRI ITAMI , HYOGO 664 JAPAN		
Mtl Dsg	Coat Typ	ANSI Type
EDW-R52	BC Medis	Oyercoat Ester-imide
		Temp Class
		155

Marking : Company name and type designation on package or reels.

See General Information Preceding These Recognitions.

For use only in equipment where the acceptability of the combination is determined by Underwriters Laboratories Inc.

Report : January 5, 1988.

302279005 H7642 Underwriters Laboratories Inc. ® D11/0149909

QMFZ2	August 31, 2002	
Plastics-Component		E91944
NIPPON PETROCHEMICALS CO LTD		
Mterial Dsg	Color	Min Thk mm
Liquid Crystal Polyester (LCP), glass filled, furnished as pellets.		
HM-402	NC , BK	0.30
		V-0
		H W I
		H A I
		Elec
		RTI Imp
		Mech Slr
		H V R
		D 4 5
		C T I

(a)-Virgin and Re grind up to 50% have the same basic characteristics.

r1-Virgin and Re grind from 1 to 50% by weight incl. have the same Flame characteristics, Tensile Impact, Tensile Strength and Heat Deflection in natural color only.

r2-Virgin and Re grind from 26-50% by weight inclusive for the colors NC, and BK liave the same Flame, and Tensile Impact characteristics.

r3-Virgin and Re grind from 26-50% by weight inclusive have the same Flame and Tensile Impact characteristics.

Marking : Company name or trademark 新日本石油化學株式會社 and material designation on container, wrapper or finished part.

10/15/2002 Underwriters Laboratories Inc. Card 8 of 9