

MOTOR PROTECTIVE CIRCUIT BREAKERS MS

Overview

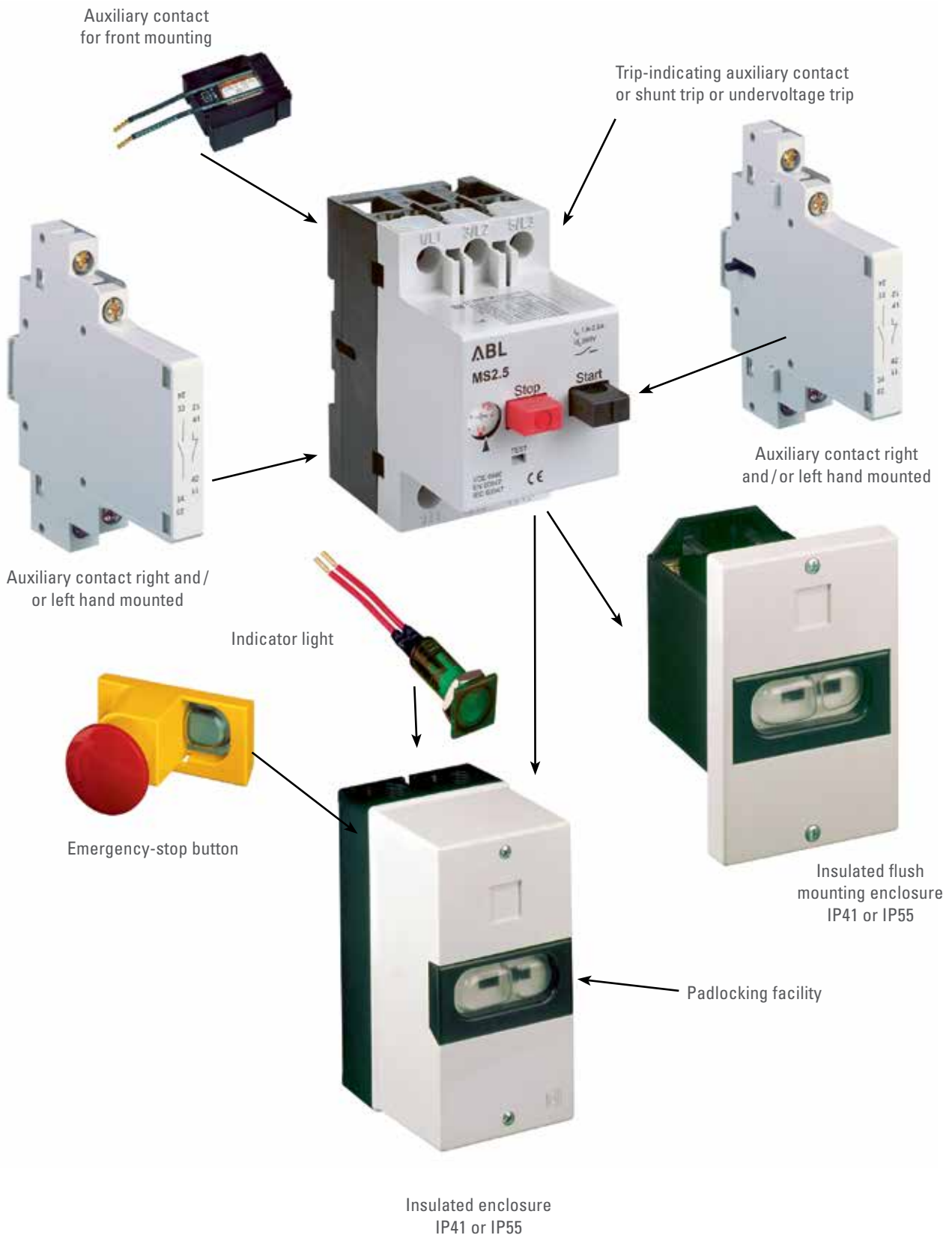

MOTOR PROTECTIVE CIRCUIT BREAKERS MS/BS

acc. to IEC 60947-4-1, UL 508

The MS motor protective circuit breakers offer optimal protection for motors and other loads up to 32 A, due to its high breaking capacity with strongly limited current.

They are equipped with phase failure sensitivity, isolating and main switch functions; 14 ranges are covering nominal rated currents from 0.1 up to 32 A.

The MPCBs are self protected up to 6.3 A at 400 V. Ranges > 6.3 A provide a short circuit withstand rating of 6 kA. The MPCBs are temperature compensated; the actuating current of the short circuit trip is $12 \times I_n$.

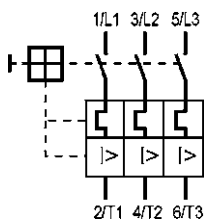

FILE E 137938



RATED CURRENT A	MAX. RATED OPERATING POWER (kW/AC 3)			OPERATING CURRENT SHORT CIRCUIT TRIP (A)	ITEM NO.	WEIGHT g/EACH	PACKING UNIT
	400/415 V	500 V	690 V				

MS with overload and short circuit tripping							
Phase failure sensitivity							
0.1 – 0.16	–	–	0.06	1.92	MS016	250	1
0.16 – 0.25	0.06	0.06	0.12	3	MS025	250	1
0.25 – 0.4	0.09	0.12	0.18	4.8	MS04	250	1
0.4 – 0.63	0.12	0.18	0.25	7.6	MS063	250	1
0.63 – 1	0.25	0.37	0.55	12	MS1	250	1
1 – 1.6	0.55	0.75	1.1	19.2	MS1.6	250	1
1.6 – 2.5	0.75	1.1	1.5	30	MS2.5	250	1
2.5 – 4	1.5	2.2	3	48	MS4	250	1
4 – 6.3	2.2	3	4	75.6	MS6.3	250	1
6.3 – 10	4	5.5	7.5	120	MS10	250	1
10 – 16	7.5	9	12.5	192	MS16	250	1
16 – 20	9	12.5	15	240	MS20	250	1
20 – 25	12.5	15	22	300	MS25	250	1
25 – 32	15	18.5	–	384	MS32	250	1

*32 A without VDE, without UL-approval

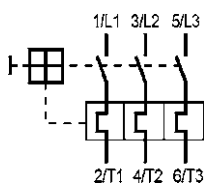

RATED CURRENT A	MAX. RATED OPERATING POWER (kW/AC 3)			OPERATING CURRENT SHORT CIRCUIT TRIP (A)	ITEM NO.	WEIGHT g/EACH	PACKING UNIT
	400/415 V	500 V	690 V				

0.4 – 0.63	0.12	0.18	0.25		BS063	230	1
0.63 – 1	0.25	0.37	0.55		BS1	230	1
1 – 1.6	0.55	0.75	1.1		BS1.6	230	1
1.6 – 2.5	0.75	1.1	1.5		BS2.5	230	1
2.5 – 4	1.5	2.2	3		BS4	230	1
4 – 6.3	2.2	3	4		BS6.3	230	1
6.3 – 10	4	5.5	7.5		BS10	230	1
10 – 16	7.5	9	12.5		BS16	230	1
16 – 20	9	12.5	15		BS20	230	1
20 – 25	12.5	15	22		BS25	230	1
25 – 32	15	18,5	-		BS32	230	1

*32 A without VDE-approval

TRANSFORMER PROTECTIVE CIRCUIT BREAKERS MST

acc. to IEC 60947-4-1

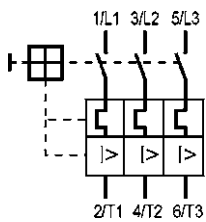

RATED CURRENT A	MAX. RATED OPERATING POWER (kW/AC 3)			OPERATING CURRENT SHORT CIRCUIT TRIP (A)	ITEM NO.	WEIGHT g/EACH	PACKING UNIT
	400/415 V	500 V	690 V				

MST with overload and short circuit tripping for transformers with high inrush currents							
0.1 – 0.16	–	–	–	3.2	MST016	250	1
0.16 – 0.25	–	0.16	–	5	MST025	250	1
0.25 – 0.4	0.16	0.25	0.25	8	MST04	250	1
0.4 – 0.63	0.25	0.4	0.4	12.6	MST063	250	1
0.63 – 1	0.4	0.63	1	20	MST1	250	1
1 – 1.6	0.63	1	–	32	MST1.6	250	1
1.6 – 2.5	1	1.6	2	50	MST2.5	250	1
2.5 – 4	1.6/1	2.5	2.5	80	MST4	250	1
4 – 6.3	2.5	4	6.3	126	MST6.3	250	1
6.3 – 10	4.0/5.0	6.3	–	200	MST10	250	1
10 – 16	6.3/8	10	10	320	MST16	250	1
16 – 20	12.5	16	–	400	MST20	250	1
20 – 25	12.5	16	–	500	MST25	250	1

MOTOR PROTECTIVE DEVICES FOR VARIABLE-SPEED FAN MOTORS



RATED CURRENT A	ITEM NO.	WEIGHT g/EACH	PACKING UNIT
--------------------	----------	------------------	-----------------

Motor protective devices for variable-speed fan motors

0,4-10	MWC10	190	1
--------	-------	-----	---

The MWC 10 is a multi-polar circuit breaker which allows a thermal contact, which is built into the motor (directly into the coil), to be analysed.

For example, if the motor is hindered due to dirt, the coil will heat up more than normal and the thermal contact (NC contact) in the coil will break the circuit.

The bimetal built into the circuit breaker recognizes the opening of the thermal contact in the motor coil and, with the smallest motor rated current, switches off all poles completely within max. 40 s.

However, this type of full motor protection neglects wiring protection. The connection from the full motor protection to the fan is not protected.

In order to protect this connection, a back-up fuse is needed which fits the conductor cross section. This back-up fuse is usually installed in front of the full motor protection.

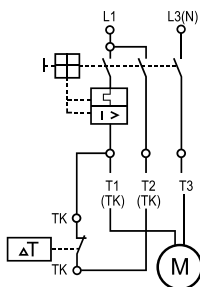

ACCESSORIES FOR MOTOR PROTECTIVE CIRCUIT BREAKERS MS



FILE E 137938



MODULES	WIRING DIAGRAM	CONTACTS	ITEM NO.	WEIGHT g/EACH	PACKING UNIT
---------	----------------	----------	----------	---------------	--------------

Auxiliary contact for side mounting

1/2 M		2 NO	HMS20	40	5
1/2 M		1 NO + 1 NC	HMS11	40	5
1/2 M		1 NO	HMS10	40	5
1/2 M		2 NC	HMS02	40	5
1/2 M		1 NC	HMS01	40	5



Early make auxiliary contact for side mounting

1/2 M		1 NO + 1 NC	VHMS11	40	5
1/2 TE		2 NO	VHMS20	40	5

ACCESSORIES FOR MOTOR PROTECTIVE CIRCUIT BREAKERS MS



	WIRING DIAGRAM	CONTACTS	ITEM NO.	WEIGHT g/EACH	PACKING UNIT
--	----------------	----------	----------	---------------	--------------

Trip-indicating auxiliary contact for inside mounting					
		1 NO	SHMS10	25	10
		1 NC	SHMS01	25	10



Auxiliary contact for front mounting					
		1 NO + 1 NC	FHMS11	13	10
		1 NO	FHMS10	11	10
		1 NC	FHMS01	11	10

Can not be used together with EHMS, SHMS, AMS and UMS.

Technical Data	HMS, VHMS	FHMS	SHMS
Rated impulse withstand voltage U_{imp}	4 000 V		
Rated operating voltage U_e	500 V	250 V	500 V
Overvoltage category/Pollution level	III/3	III/3	III/3
Max. current (with free air circulation) I_{th}	6A	5A	6A
Rated operating current I_e	3.5/2 A	1 A/-	2/1 A
Can also be used for low voltage and PLC-inputs	24 V DC, 10 mA		
Cross section: 1 conductor mm ² 2 conductor mm ² only HMS, VHMS	0.75 – 2.5 r; 0.75 – 1.5 f (with ferrule) 0.75 – 2.5 r; 0.75 – 1.5 f (with ferrule)		

It is possible to equip the breakers with different auxiliary contacts. Auxiliary contacts HMS, FHMS and EHMS operate in accordance with the main contacts. They are designed for remote signaling, electrical interlocking and control applications. Early make contacts VHMS operate earlier than the main contacts. Trip-indicating auxiliary contacts SHMS operate in case of a fault.

ACCESSORIES FOR MOTOR PROTECTIVE CIRCUIT BREAKERS MS



FILE E 137938

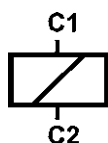

	RATED OPERATING VOLTAGE	ITEM NO.	WEIGHT g/EACH	PACKING UNIT
--	-------------------------	----------	---------------	--------------

Shunt trip for inside mounting with connecting cable (140 mm long)				
	110 V 50 Hz, 120 V 60 Hz	AMS110	75	10
	220-230V 50 Hz, 240 V 60 Hz	AMS220	75	10
	380-415 V 50 Hz, 440 V 60 Hz	AMS380	75	10
	24 V 50/60 Hz	AMS24	75	10
	500 V 50 Hz	AMS500	75	10
	24 V DC	AMSD24	75	10
Pull-in voltage $0,7 \times U_e$			Switch in duration for U_e 100% AC	

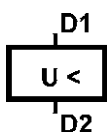

Undervoltage trip for inside mounting with connecting cable (140 mm long)				
	110 V 50 Hz, 120 V 60 Hz	UMS110	75	10
	220-230 V 50 Hz, 240 V 60 Hz	UMS220	75	10
	380-415 V 50 Hz, 440 V 60 Hz	UMS380	75	10
	24 V 50/60 Hz	UMS24	75	10
	500 V 50 Hz	UMS500	75	10
Pull-in voltage $\geq 0.85 \times U_e$		Drop out voltage $0,35 - 0,7 \times U_e$		Switch in duration for U_e
				100%

ACCESSORIES FOR MOTOR PROTECTIVE CIRCUIT BREAKERS MS



INSULATED ENCLOSURE IP41
with integrated PE(N)
terminal top and bottom each
2 metric knock-outs

	ITEM NO.	WEIGHT g/EACH	PACKING UNIT
	MS.G41	220	1



INSULATED FLUSH MOUNTING
ENCLOSURE IP41
with integrated PE(N) terminal

	ITEM NO.	WEIGHT g/EACH	PACKING UNIT
	MS.F41	150	1



INSULATED ENCLOSURE IP55
with integrated PE(N)
terminal top and bottom each
2 metric knock-outs

	ITEM NO.	WEIGHT g/EACH	PACKING UNIT
	MS.G55	240	1



INSULATED FLUSH MOUNTING
ENCLOSURE IP55
with integrated PE(N) terminal

	ITEM NO.	WEIGHT g/EACH	PACKING UNIT
	MS.F55	170	1



INSULATED ENCLOSURE
WITH CEE-PLUG IP54
16 A 400 V
1 opening at the bottom

NO. OF POLES	ITEM NO.	WEIGHT g/EACH	PACKING UNIT
5-pole	MS.C51	420	1
4-pole	MS.C41	415	1
3-pole	MS.C31	410	1



INSULATED ENCLOSURE WITH
CEE-PLUG IP54 AND PHASE-IN-
VERTER
16 A 400 V
1 opening at the bottom

NO. OF POLES	ITEM NO.	WEIGHT g/EACH	PACKING UNIT
5-pol.	MS.P51	420	1



INSULATED ENCLOSURE WITH
IP54 SCHUKO EARTHED PLUG
with 2 earthing systems
acc. to CEE7/VII
16 A 250 V, 2-pole + ⊕
1 opening at the bottom

NO. OF POLES	ITEM NO.	WEIGHT g/EACH	PACKING UNIT
2-pole+ ⊕	MS.C21	410	1

Max. assembly of insulated enclosures

ITEM NO.	MS/BS	HMS VHMS	AMS/UMS SHMS/FHMS	MS.PT/MS.PV MS.PS2/MS.VS	MS.BS	MS.N	MS.SL
MS.G41	1	2	1	1	1	2	1
MS.G55	1	2	1	1	-	2	1
MS.F41	1	2	1	1	1	2	1
MS.F55	1	2	1	1	-	2	1
MS.C21	1	-	1	-	-	-	-
MS.C31	1	-	1	-	-	-	-
MS.C41	1	-	1	-	-	-	-
MS.C51	1	-	1	-	-	-	-
MS.P51	1	-	1	-	-	-	-

ACCESSORIES FOR MOTOR PROTECTIVE CIRCUIT BREAKERS MS



STOP BUTTON
not latching
red, on grey surface

	ITEM NO.	WEIGHT g / EACH	PACKING UNIT
	MS.PT	55	5



PADLOCKING FACILITY
for up to three padlocks

	ITEM NO.	WEIGHT g / EACH	PACKING UNIT
	MS.VS	100	10



EMERGENCY-STOP BUTTON
latching, turn to release
red, on yellow surface

	ITEM NO.	WEIGHT g / EACH	PACKING UNIT
	MS.PV	60	5



KIT IP55
to increase degree of protection
from IP41 to IP55

	ITEM NO.	WEIGHT g / EACH	PACKING UNIT
	MS.BS	25	10



EMERGENCY-STOP BUTTON
latching, key release (2 keys)
red, on yellow surface

	ITEM NO.	WEIGHT g / EACH	PACKING UNIT
	MS.PS2	65	5



N-TERMINAL
connecting of fifth conductor

	ITEM NO.	WEIGHT g / EACH	PACKING UNIT
	MS.N	10	10



INDICATOR LIGHT
with glow bulb,
nominal rated voltage: 220-240 V

COLOUR	ITEM NO.	WEIGHT g / EACH	PACKING UNIT
green	MS.SLG2	10	5



INDICATOR LIGHT
with glow bulb,
nominal rated voltage: 380-440 V

COLOUR	ITEM NO.	WEIGHT g / EACH	PACKING UNIT
green	MS.SLG3	10	5

ACCESSORIES FOR MOTOR PROTECTIVE CIRCUIT BREAKERS MS

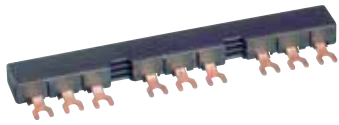

DESCRIPTION	MAX. BUSBAR CURRENT (A)	LENGTH	ITEM NO.	WEIGHT g/EACH	PACKING UNIT
-------------	-------------------------	--------	----------	---------------	--------------

Busbars					
for 2 MPCBs without auxiliary contacts	63	90 mm	SB.D02	37	10
for 3 MPCBs without auxiliary contacts	63	136 mm	SB.D03	55	10
for 4 MPCBs without auxiliary contacts	63	180 mm	SB.D04	75	10
for 2 MPCBs each with 1 auxiliary contact fitted on the right side	63	99 mm	SB.D12	40	10
for 3 MPCBs each with 1 auxiliary contact fitted on the right side	63	153 mm	SB.D13	65	10
for 4 MPCBs each with 1 auxiliary contact fitted on the right side	63	207 mm	SB.D14	90	10
for 5 MPCBs each with 1 auxiliary contact fitted on the right side	63	261 mm	SB.D15	115	10
for 2 MPCBs each with 2 auxiliary contacts	63	108 mm	SB.D22	45	10
for 4 MPCBs each with 2 auxiliary contacts	63	234 mm	SB.D24	105	10



Incoming terminal block					
	63		SB.DE1	30	10



Shroud					
			SB.DA1	5	10

MOTOR PROTECTIVE CIRCUIT BREAKERS MS

Technical Data

Standards	IEC 60947-4-1, DIN EN 60947-4-1, VDE 0660-102
Mechanical endurance	5000 switching cycles
Electrical endurance	1000 switching cycles
Max. operating frequency	30 switching cycles / h
Ambient temperature not enclosed, max./min. enclosed, max./min.	-20°C to +55°C -20°C to 40°C
Resistance to mechanical shocks	15 g / 10 ms
Installation position	any, in IP41 enclosure vertical
Cross section (1 or 2 conductors)	1.0 – 6 r; 0.75 – 4 f (with ferrule) 2 conductors differing by not more than 2 sizes
Torque for terminal screws · Main conductor · Auxiliary conductor · Auxiliary contact for front mounting	1.2 Nm 1.0 Nm 0.5 Nm
Rated impulse withstand voltage U_{imp}	6 000 V
Overvoltage category / Pollution level	III / 3
Rated operating voltage U_e	690 V AC
Rated operating current I_e	0.16 – 32 A according to setting range
Frequency	40...60 Hz
	At higher frequencies, the electromagnetic tripping values rise by a factor of about 1.1 at 100 Hz; 1.2 at 200 Hz; 1.4 at 400 Hz; 1.5 at 500 Hz
Utilization category (IEC 60947-4-1, DIN EN 60947-4-1, VDE 0660-102)	AC-3 max. 690 V
Temperature compensation (reference values to VDE / IEC)	-5°C / +40°C
Temperature compensation Operating range	-20°C...+55°C
Power loss in watt per path of current	by min. setting range 0.6 – 1.05 W / by max. setting range 1.5 – 2.6 W

Rated short circuit withstand rating I_{cu} MS IEC 60947-2, DIN EN 60947-2, VDE 0660-101

UPPER SETTING THERMAL TRIPPING	I_{cu} (kA)				CURRENT LIMITER SBMS32 · I_{cu} (kA)	
	230 V	400 V	500 V	690 V	230 V	400 V
0,16 – 1,6 A	No additional protective devices needed inherently stable for any selected short circuit currents				No additional protective devices needed inherently stable for any selected short circuit currents	
2,5 – 6,3 A			3	2,5		
10 A		6	3	2,5		50
16 – 32 A	10	6	2,5	2	100	50

Switching times at short circuit
 minimum command time 2 ms
 opening delay 2 ms
 opening time 7 ms

MOTOR PROTECTIVE CIRCUIT BREAKERS MS

Technical Data

Back-up-protection MS (if the short circuit current is higher than the short circuit withstand rating of MS)

RATED CURRENT	BACK-UP FUSE (gL, aM) (A)			
	230 V	400 V	500 V	690 V
0,1 - 0,16 A	No back-up fuse necessary inherently stable for any selected short circuit currents			
0,16 - 0,25 A				
0,25 - 0,4 A				
0,4 - 0,63 A				
0,63 - 1 A				
1 - 1,6 A				
1,6 - 2,5 A				
2,5 - 4 A				
4 - 6,3 A				
6,3 - 10 A			80	25
10 - 16 A	80	80	50	20
16 - 20 A	80	80	63	25
20 - 25 A	80	80	63	35
25 - 32 A	80	80	63	35
			50	50

Back-up-protection BS

RATED CURRENT (A)	FUSE (A)	RATED CURRENT (A)	FUSE (A)	RATED CURRENT (A)	FUSE (A)
0,4 - 0,63	2	2,5 - 4	10	16 - 20	50
0,63 - 1	4	4 - 6,3	16	20 - 25	50
1 - 1,6	6	6,3 - 10	25	25 - 32	50
1,6 - 2,5	6	10 - 16	35		

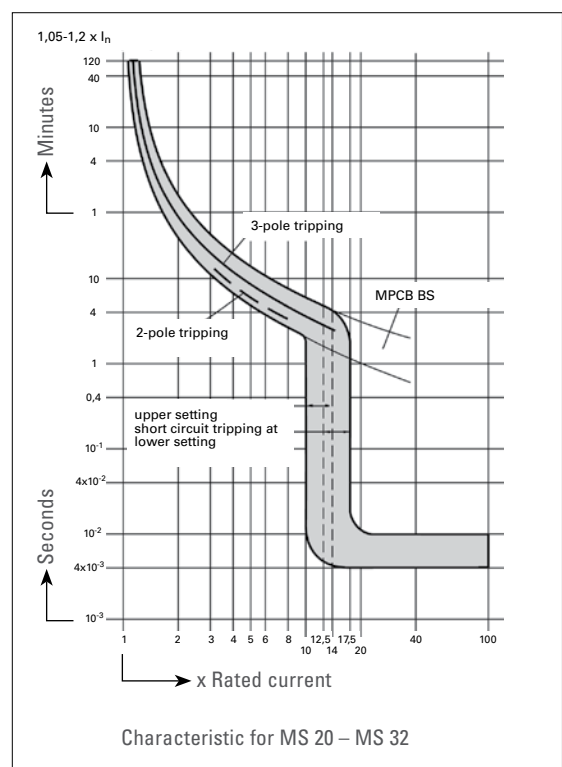
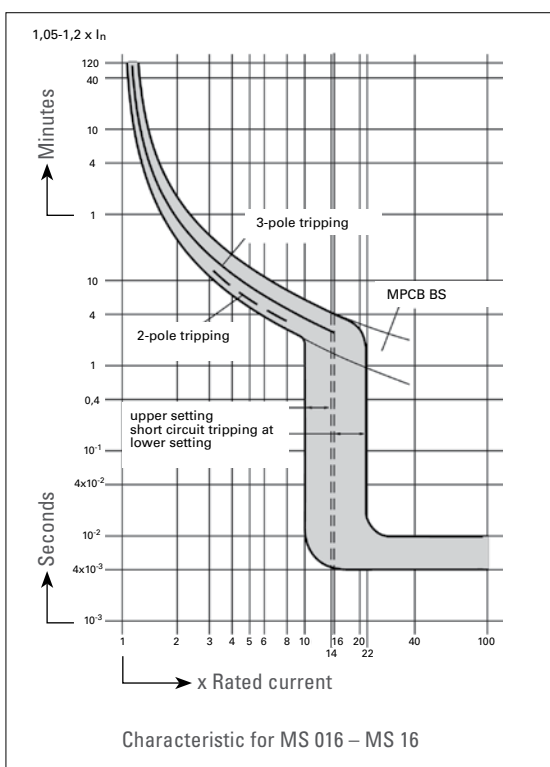

MOTOR PROTECTIVE CIRCUIT BREAKERS MS

Dimension Drawings

Motor protective circuit breaker MS

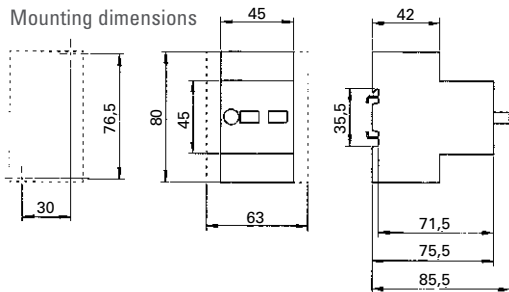

Current limiter SBMS32

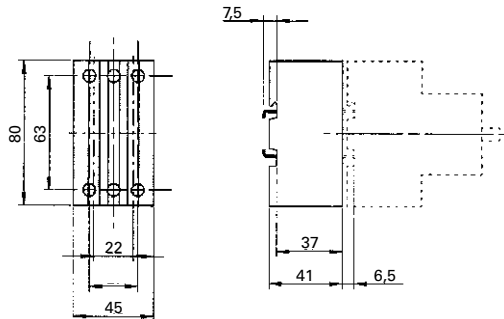

Insulated enclosure IP41 / IP55 MS.G41 / MS.G55

possible to integrate 1 MPCB and 2 side mounted auxiliary contacts

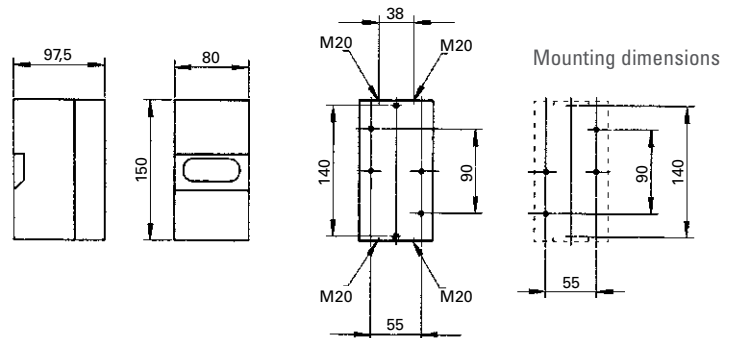

Insulated flush mounting enclosure MS.F41 / MS.F55

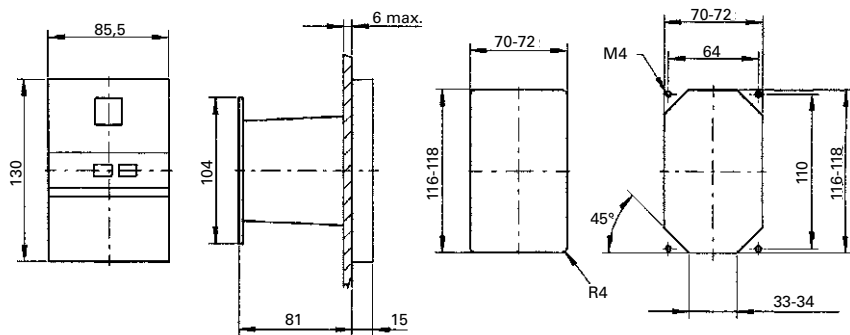

Insulated enclosure with CEE plug

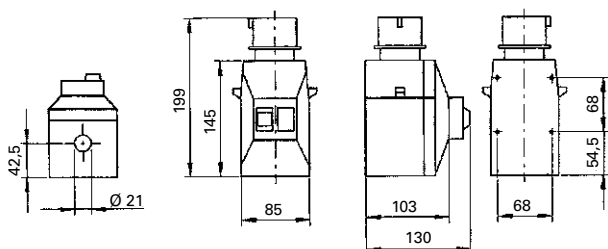

Emergency-stop button MS.PT – PS.PS2

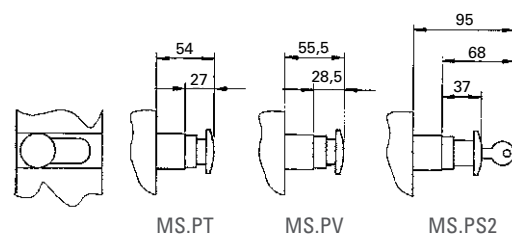

MOTOR PROTECTIVE CIRCUIT BREAKERS MA

Overview

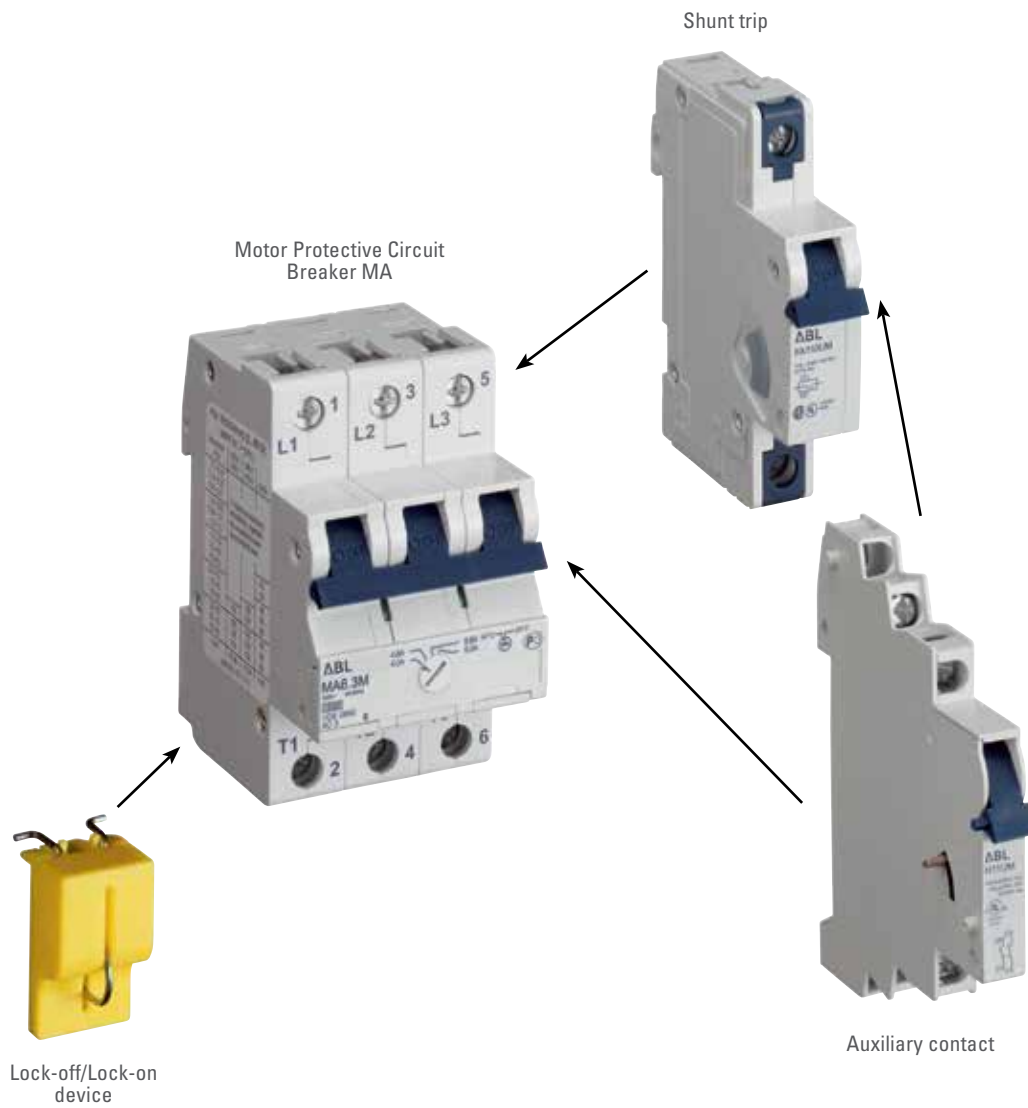

MOTOR PROTECTIVE CIRCUIT BREAKERS MA

IEC 60947

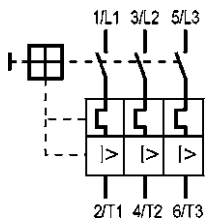

RATED CURRENT [A]	MAX. RATED OPERATING POWER (KW/AC 3)			OPERATING CURRENT SHORT CIRCUIT TRIP [A]	ITEM NO.	WEIGHT G / EACH	PACKING UNIT
	400/415 V	500 V	690 V				

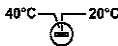
MA with overload and short circuit tripping
 Temperature compensation from +20°C bis +40°C adjustable 

0,1 – 0,16	–	–		1,92	MA016M	450	1
0,16 – 0,25	0,06	0,06		3	MA025M	450	1
0,25 – 0,4	0,09	0,12		4,8	MA040M	450	1
0,4 – 0,63	0,12	0,25		7,6	MA063M	450	1
0,63 – 1	0,25	0,37		12	MA1.0M	450	1
1 – 1,6	0,55	0,75		19,2	MA1.6M	450	1
1,6 – 2,5	0,75	1,1		30	MA2.5M	450	1
2,5 – 4	1,5	2,2		48	MA4.0M	450	1
4 – 6,3	2,2	3		75,6	MA6.3M	450	1
6,3 – 10	4	4		120	MA10M	450	1
10 – 16	7,5	9		192	MA16M	450	1
16 – 20	9	12,5		240	MA20M	450	1
20 – 25	12,5	15		300	MA25M	450	1
25 – 32	15	18,5		348	MA32M	450	1
32 – 40	18,5	22		480	MA40M	450	1

ACCESSORIES

for motor protective circuit breakers MA



Shunt trip					
MODULE	RATED OPERATING VOLTAGE	MAX. OPERATING CURRENT AT U_n ($t < 10$ ms)	ITEM NO.	WEIGHT g/EACH	PACKING UNIT
1	12 V \approx	1,3 A	FA12UM	105	5
1	24 V \approx	0,6 A	FA24UM	105	5
1	48 - 72 V \approx	0,2 A	FA48UM	105	5
1	110 - 240 V \approx , 415 V~	0,25 A at 110 V 0,5 A at 240 V 0,8 A at 415 V	FA110UM	105	5
Pull-in voltage $0.7 \times U_e$			Switch in duration for U_e 100%		



Auxiliary contact					
MODULE	TYPE OF CONTACT	CONTACTS	ITEM NO.	WEIGHT g/EACH	PACKING UNIT
1/2	1 auxiliary contact	1NO	H10UM	35	10
1/2	2 auxiliary contacts	1NO + 1NC	H11UM	40	10
1/2	3 auxiliary contacts	1NO + 2NC	H12UM	45	10
1/2	3 auxiliary contacts	2NO + 1NC	H21UM	45	10

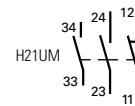
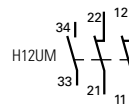
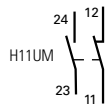
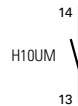

Standards	according to IEC 60947-5-1, DIN EN 60947-5-1, VDE 0660-200, UL 508	
Rated operating currents	10 A / 240 V AC 3 A / 110 V DC 1 A / 220 V DC	
Minimum contact load	1 mA at 24 V DC	
Conductor cross sections		
Type of conductor *)	min.	max.
Single wire	0.5 mm ²	2.5 mm ²
Stranded wire	0.5 mm ²	1.5 mm ²
Stranded wire with ferrule	0.5 mm ²	1.5 mm ²
Torque	max. 0.8 Nm	

*) Stripped length 8 - 9 mm

ACCESSORIES

for motor protective circuit breakers MA

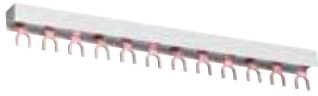

Busbars

CROSS SECTION (mm ²)	BUSBAR CURRENT START OF BUSBAR/ MIDDLE INFEEED	MODULES/ PHASES	ITEM NO.	WEIGHT g/EACH	PACKING UNIT	PASSENDE ENDKAPPE ART.-NR.
----------------------------------	--	-----------------	----------	---------------	--------------	----------------------------

3 phase

10	63/100	4/3	SB31210	84	25	SB.A1
10	63/100	19/3	SB36010	420	20	SB.A1
16	80/130	19/3	SB36016	675	20	SB.A2

3 phase 3-pole circuit breaker + auxiliary contact

16	80/130	16/3	SB36316	630	20	SB.A2
----	--------	------	----------------	-----	----	-------



DISTANCE DEVICE 9 MM

MODULE	ITEM NO.	WEIGHT g/EACH	PACKING UNIT
--------	----------	---------------	--------------

½	HDS	7	10
---	-----	---	----



LOCK-OFF/LOCK-ON DEVICE

For miniature circuit breakers and motor protective circuit breakers

ITEM NO.	WEIGHT g/EACH	PACKING UNIT
----------	---------------	--------------

EASS	4	10
-------------	---	----

MOTOR PROTECTIVE CIRCUIT BREAKERS MA

Technical Data		
Standards	IEC 60947-2, DIN EN 60947-2, VDE 0660-101 IEC 60947-4-1, DIN EN 60947-4-1, VDE 0660-102 DIN VDE 0100, DIN VDE 0110, DIN VDE 0113	
Short circuit withstand rating	10 kA at 240/415 V~	
Utilization category	AC 3 at U_e 415 V~ (up to I_n 25 A)	
Max. back-up fuse	Fuse according to DIN-VDE 0636 100 A operating class gL for 240/415 V~ (only for $I_n > 10$ A)	
Rated voltage	500 V~ / 50-60 Hz	
Rated current range	15 setting ranges from 0.1 up to 40 A	
Rated uninterrupted current I_{th}	40 A	
Tripping time at $6 \times I_e$	> 5s/TII	
Test currents	Thermal not tripping I_1 (A) > 2 h	$1.05 \times I_e$
	Thermal tripping I_2 (A) < 2 h	$1.2 \times I_e$
	Electromagnetic not tripping I_4 (A) > 0.1 s	for the lower setting $16 \times I_e$ ($12.5 \times I_e > 16$ A) for the upper setting $10 \times I_e$
	Electromagnetic tripping I_5 (A) < 0.1 s	for the lower setting $19 \times I_e$ ($15 \times I_e > 16$ A) for the upper setting $12 \times I_e$
Temperature compensation	up to +40°C	
Permitted ambient temperature	open -20°C to +50°C, enclosure -20°C to +40°C storage/transport -40°C to +70°C	
Device depth according to DIN 43880	68 mm	
Mechanical endurance	30 000 switching cycles (30 000 ON / 30 000 OFF)	
Permitted operating frequency	30 switching cycles / h	
Protection cover	Safe for fingers and back of hand acc. to DIN EN 50274, VDE 0660-514 BGV A2	
Degree of protection according to EN/IEC 60529	IP20	
Installation position	any	
Mounting	On DIN-rail acc. to DIN EN 60715 35 mm	
Lockability	The handle can be secured against manual switching in the on and off position by a lead seal	
Climatic resistance	Humid heat constant according to DIN IEC 60068-2 – 78 Humid heat cyclic according to DIN EN 60068-2 – 30	
Vibration resistance	> 15 g according to DIN EN 60068-2 – 59 for a load with I_1	
Resistance to mechanical shocks	25 g 11 ms	

MOTOR PROTECTIVE CIRCUIT BREAKERS MA

Conductor cross sections

	BOX TERMINAL BOTTOM		BOX TERMINAL TOP	
Type of conductor *)	max.	min.	max.	min.
Single wire	25 mm ²	0.5 mm ²	25 mm ²	0.5 mm ²
Multiple wire	25 mm ²	(16 mm ²)	25 mm ²	(16 mm ²)
Stranded wire	16 mm ²	0.5 mm ²	16 mm ²	0.5 mm ²
Stranded wire with ferrule	16 mm ²	0.5 mm ²	16 mm ²	0.5 mm ²
Busbar Cable lug	up to 3 mm thickness		up to 1.5 mm thickness	
Combined, conductor and busbar or cable lug	up to 25 mm ² and up to 2 mm thickness		not possible	
Torque	max. 2.5 Nm			

*) Stripped length: bottom 12 - 14 mm, top 10 - 12 mm

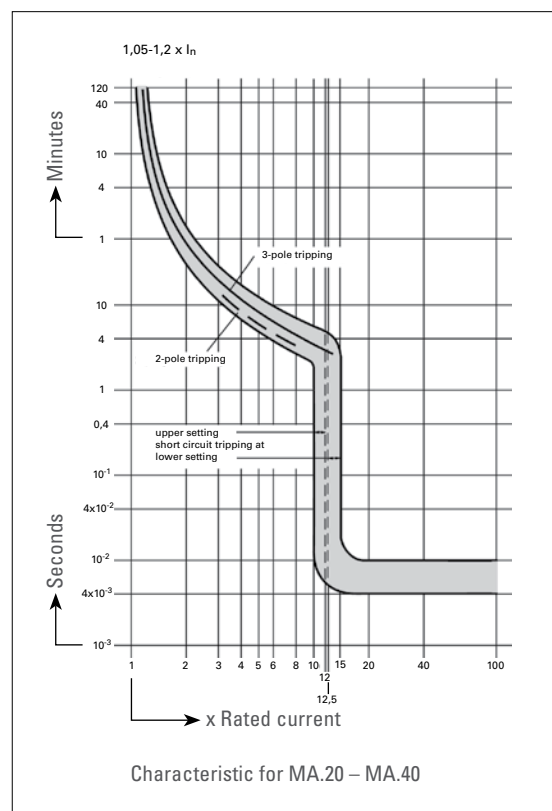
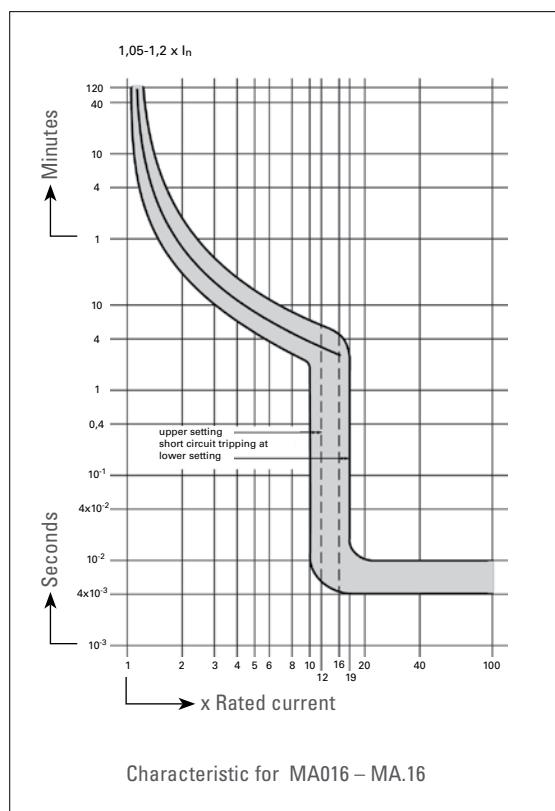

MOTOR PROTECTIVE CIRCUIT BREAKERS MA

Internal resistance per pole in mΩ and power loss in Watt of the complete device

TYPE	LOWER SETTING A	UPPER SETTING A	INTERNAL RESISTANCE PER POLE mΩ	POWER LOSS FOR THE COMPLETE DEVICE FOR	
				LOWER SETTING Watt	UPPER SETTING Watt
MA016M	0,10	0,16	85500	2,6	6,6
MA025M	0,16	0,25	35000	2,7	6,6
MA040M	0,25	0,40	15000	2,8	7,2
MA063M	0,40	0,63	5200	2,5	6,2
MA1.0M	0,63	1,0	2300	2,7	6,9
MA1.6M	1,0	1,6	950	2,9	7,3
MA2.5M	1,6	2,5	355	2,7	6,7
MA4.0M	2,5	4,0	142	2,7	6,8
MA6.3M	4,0	6,3	54	2,6	6,4
MA.10M	6,3	10	28	3,3	8,4
MA.16M	10	16	13,9	4,2	10,7
MA.20M	16	20	9,9	7,6	11,9
MA.25M	20	25	6,3	7,6	11,8
MA.32M	25	32	3,85	7,2	11,8
MA.40M	32	40	3,1	9,5	14,9

RATED CURRENTS (A)	RATED SHORT CIRCUIT WITHSTAND RATING I_{cu} ACCORDING TO IEC 60947-2, DIN EN 60947-2 I_{cu} (kA)			BACK-UP PROTECTION. IF THE SHORT CIRCUIT CURRENT EXCEEDS THE SHORT CIRCUIT WITHSTAND RATING BACK-UP FUSE (gL, aM) A WENN $I_{cc} > I_{cn}$		
	230 V	400 V	500 V	230 V	400 V	500 V

0,1 – 0,16	No additional protective devices needed inherently stable for any selected short circuit currents			No back-up fuse necessary inherently stable for any selected short circuit currents		
0,16 – 0,25						
0,25 – 0,4						
0,4 – 0,63						
0,63 – 1						
1 – 1,6						
1,6 – 2,5						
2,5 – 4				63		
4 – 6,3				63		
6,3 – 10				80		
10 – 16	10			80		
16 – 20	15	10	6	100	100	80
20 – 25	15	10	6	100	100	80
25 – 32	15	10	6	100	100	80
32 – 40	15	10	6	100	100	80

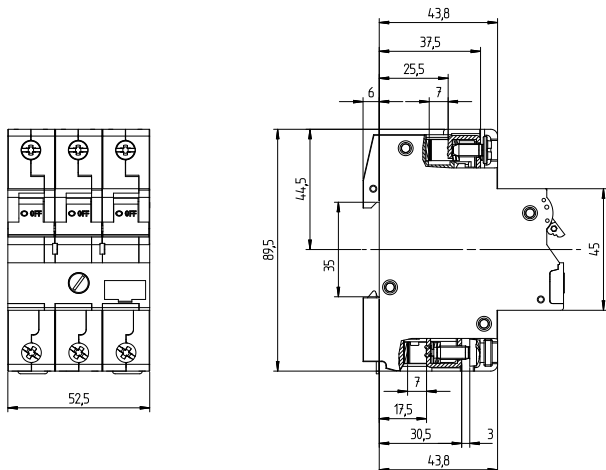

MOTOR PROTECTIVE CIRCUIT BREAKERS MS AND MA

Nominal rated motor currents

Nominal rated motor currents for three-phase motors (reference values for cage rotors)

Lowest possible short circuit fuse for three-phase motors. The maximum value is calculated according to setting range.

MOTOR POWER			230 V NOMINAL RATED MOTOR CURRENT	FUSE START-UP DIRECT	Y/Δ	400 V NOMINAL RATED MOTOR CURRENT	FUSE START-UP DIRECT	Y/Δ	500 V NOMINAL RATED MOTOR CURRENT	FUSE START-UP DIRECT	Y/Δ	690 V NOMINAL RATED MOTOR CURRENT	FUSE START-UP DIRECT	Y/Δ
kW	cos. φ	%	A	A	A	A	A	A	A	A	A	A	A	A
0,06	0,7	58	0,37	2	-	0,21	2	-	0,17	2	-	0,12	2	-
0,09	0,7	60	0,54	2	-	0,31	2	-	0,25	2	-	0,18	2	-
0,12	0,7	60	0,72	4	2	0,41	2	-	0,33	2	-	0,24	2	-
0,18	0,7	62	1,04	4	2	0,6	2	-	0,48	2	-	0,35	2	-
0,25	0,7	62	1,4	4	2	0,8	4	2	0,7	2	-	0,43	2	-
0,37	0,72	62	2	6	4	1,2	4	2	0,9	2	2	0,7	2	-
0,55	0,75	69	2,7	10	4	1,5	4	2	1,2	4	2	0,9	4	2
0,75	0,78	74	3,2	10	4	1,9	6	4	1,5	4	2	1,1	4	2
1,1	0,81	74	4,6	10	6	2,6	6	4	2,1	6	4	1,5	4	2
1,5	0,81	74	6,3	16	10	3,6	6	4	2,9	6	4	2,1	6	4
2,2	0,81	78	8,7	20	10	5	10	6	4	10	4	2,9	10	4
3	0,82	80	11,5	25	16	6,6	16	10	5,3	16	6	3,8	10	4
4	0,82	83	14,8	32	16	8,5	20	10	6,8	16	10	4,9	16	6
5,5	0,82	86	19,6	32	25	11,3	25	16	9	20	16	6,5	16	10
7,5	0,82	87	26,4	50	32	15,2	32	16	12,1	25	16	8,8	20	10
11	0,84	87	38	80	40	21,7	40	25	17,4	32	20	12,6	25	16
15	0,84	88	51	100	63	29,3	63	32	23,4	50	25	17	32	20
18,5	0,84	88	63	125	80	36	63	40	28,9	50	32	20,9	32	25
22	0,84	92	71	125	80	41	80	50	33	63	32	23,8	50	25
30	0,85	92	96	200	100	55	100	63	44	80	50	32	63	32
37	0,86	92	117	200	125	68	125	80	54	100	63	39	80	50
45	0,86	93	141	250	160	81	160	100	65	125	80	47	80	63
55	0,86	93	173	250	200	99	200	125	79	160	80	58	100	63
75	0,86	94	233	315	250	134	200	160	107	200	125	78	160	100
90	0,86	94	279	400	315	161	250	200	129	200	160	93	160	100
110	0,86	94	342	500	400	196	315	200	157	250	160	114	200	125
132	0,87	95	401	630	500	231	400	250	184	250	200	134	250	160
160	0,87	95	486	630	630	279	400	315	224	315	250	162	250	200
200	0,87	95	607	800	630	349	500	400	279	400	315	202	315	250
250	0,87	95	-	-	-	437	630	500	349	500	400	253	400	315
315	0,87	96	-	-	-	544	800	630	436	630	500	316	500	400
400	0,88	96	-	-	-	683	1000	800	547	800	630	396	630	400
450	0,88	96	-	-	-	769	1000	800	615	800	630	446	630	630
500	0,88	97	-	-	-	-	-	-	-	-	-	491	630	630
560	0,88	97	-	-	-	-	-	-	-	-	-	550	800	630
630	0,88	97	-	-	-	-	-	-	-	-	-	618	800	630

The nominal rated motor currents are valid for normal three-phase motors with surface and internal surface cooling with 1500 min-1.

Start-up direct: Start-up current max. 6 x nominal rated motor current
Start-up time max. 5 s.

Y/Δ Start-up: Start-up current max. 2 x nominal rated motor current
Start-up time max. 15 s.
Set motor circuit breaker relays in a line to 0.58 x protective nominal rated motor current.

Nominal rated fuse currents for Y/Δ starts are also valid for three-phase motors with slip ring rotors.

Use larger fuses for a higher rated current, start-up current and / or a longer start-up time.

The table is valid for "delayed-action" or "gl" fuses (DIN VDE 0636)

For NH-fuses with aM characteristic, fuse = nominal rated current is selected.