

1. 概述 INTRODUCTION

微波带通滤波器 LF 系列产品设计用于 WLAN、GSM、Bluetooth、PDA 和无绳电话机中，具有低的插入损耗、高的衰减和小体积 SMD 片式设计，能减少复杂的调校工作，可以简化电路设计。

Microwave Band-Pass filter LF series are designed to be used in WLAN、GSM、Bluetooth、PDA & cordless phones with low insertion loss and high attenuation as well as small size SMD chip design , which can simplify your complex tuning and circuit design .

2. 型号 Part Number

LF 31 B2450 P56 - N22

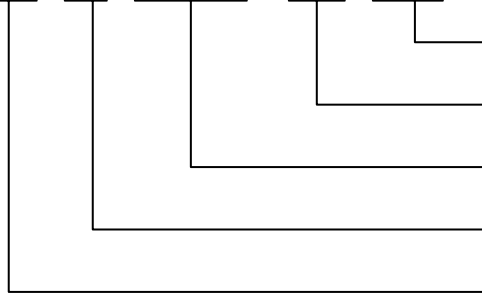

标准规格，编号 N22/Normaling Type: N22

平面设计结构/Planar Design Series: P56

带通滤波器/Band Pass Filter: 2450MHz

产品尺寸/Size: 3.2×1.6×1.2

多层结构滤波器/Multi-layer Filter

3. 外型尺寸 Dimensions (Unit: mm)

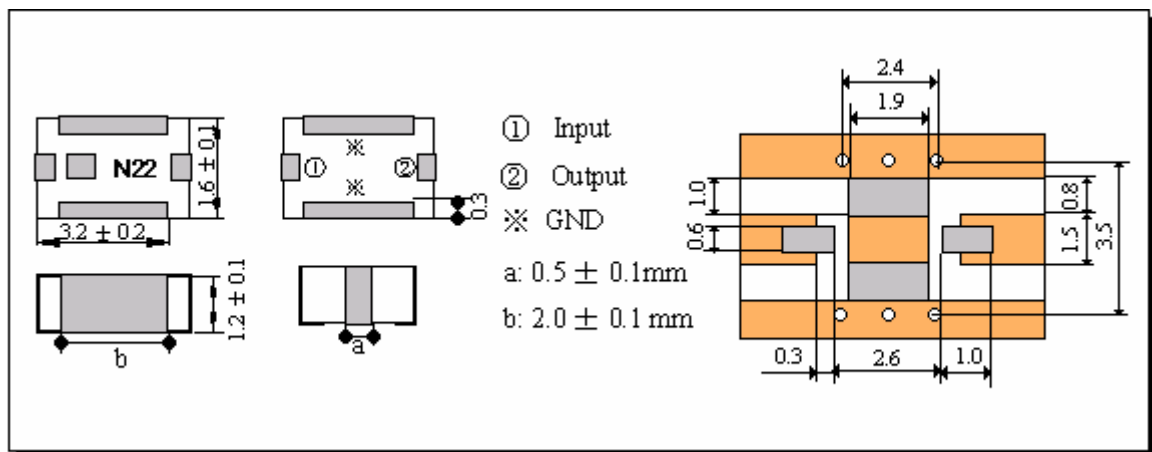

4. 结构及材料 Structure and Material

No	Part Name	名称	Structure and Material	结构及材料
4.1	Resonator	谐振体	Dielectric Material	LTCC 介质材料
4.2	In/Output Terminals	输入/输出	Ag	银
4.3	Ground Base	接地面	Ag	银

5. 电气性能

Electrical Characteristics

No.	Item (项目)	Specifications (特性)
5.1	Center Frequency 中心频率 f_0	2450.0 MHz
5.2	Insertion Loss 插入损耗	$\leq 2.3\text{dB}$ (at $25^\circ\text{C} \pm 5^\circ\text{C}$)
		$\leq 2.6\text{dB}$ (at $-40^\circ\text{C} \sim 85^\circ\text{C}$)
5.3	Band Width 通带宽度	$f_0 \pm 50\text{ MHz}$
5.4	Ripple (in BW) 通带波动	$\leq 0.8\text{ dB}$
5.5	V.S.W.R (in BW) 驻波比	≤ 2.0
5.6	Attenuation 阻带衰耗	$\geq 38\text{dB}$ (902~928MHz)
		$\geq 22\text{dB}$ (2100~2200MHz)
		$\geq 30\text{dB}$ (4800~5000MHz)
5.7	Permissible Input Power 输入功率 (MAX)	0.5 W
5.8	In/Output Impedance 输入/输出阻抗	50 Ω

6. 特性曲线

Characteristic curve

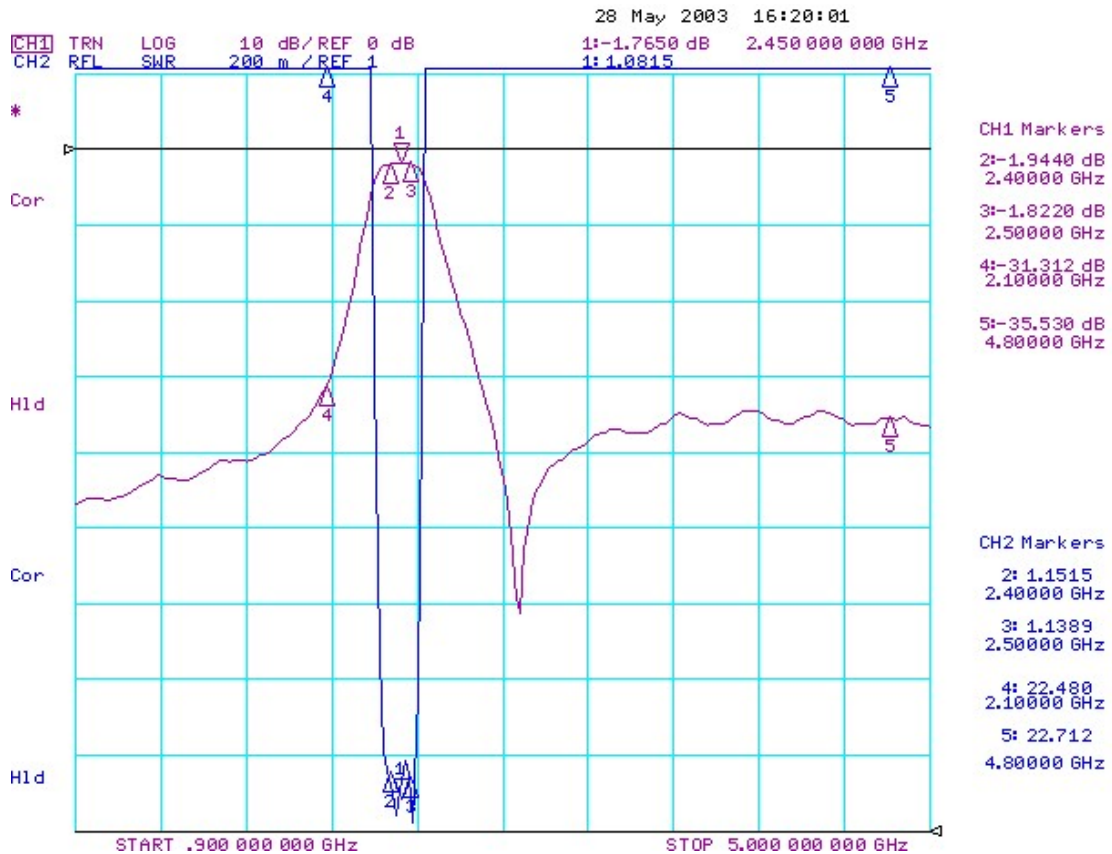

7 环境试验后允许误差 Post Environmental Tolerance

经环境试验后允许比起始读数偏差见下表

Post Environmental Tolerance (Refer to the table)

No.	Item (项目)	Post Environmental Tolerance (环境试验后允许附加误差)
7.1	Center Frequency 中心频率 fo	± 2.0 MHz
7.2	Insertion Loss 插入衰耗	± 0.5 dB
7.3	Band Width 通带宽度	± 1.0 MHz
7.4	Ripple (in BW) 通带波动	± 0.5 dB
7.5	V.S.W.R (in BW) 驻波比	± 0.2
7.6	Attenuation 阻带衰耗	± 2.0 dB

8 环境试验 Environmental Test

基准条件: 温度范围 Temperature range	25 ± 5 °C
相对湿度范围 Relative Humidity range	55~75%RH
工作温度 Operating Temperature range	-40°C ~+85°C
贮藏温度 Storage Temperature range	-40°C ~+85°C

8.1 耐振动 Vibration Resist

在振动频率为 10~55Hz 振幅为 1.5mm 沿 X.Y.Z 方向各振动 2 小时后测试符合表 7.1~7.6 规定。

The device should satisfy the electrical characteristics specified in paragraph 7.1~7.6 after applied to the vibration of 10 to 55Hz with amplitude of 1.5mm for 2 hours each in X, Y and Z directions.

8.2 耐跌落冲击 Drop Shock

在 100cm 高度处按 X, Y, Z 三个面分别自由跌落在木制地板上共 3 次后测试符合表 7.1~7.6 规定。

The device should satisfy the electrical characteristics specified in paragraph 7.1~7.6 after dropping onto the hard wooden board from the height of 100cm for 3 times each facet of the 3 dimensions of the device.

8.3 耐焊接热 Solder Heat Proof

能承受经 120~150°C 的温度预热 120 秒后, 在 230°C+10°C 的焊锡浸 5 ± 0.5 秒。

The device should be satisfied after preheating at 120°C~150°C for 120 seconds and dipping in soldering Sn at 230°C+5°C for 5 ± 0.5 seconds.

8.4 结合力试验 Tensile Strength of Terminal

在产品电极端子上或表面上应能承受 1kg 垂直拉力 10 ± 1 秒。

The device should not be broken after tensile force of 1.0kg is slowly applied to pull a lead pin of the fixed device in the lead axis direction for 10 ± 1 seconds.

8.5 耐弯曲试验 Bending Resist Test

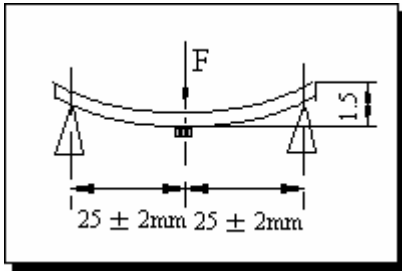

将产品按图焊在 $1.6 \pm 0.2\text{mm}$ 的 PCB 板中间，由箭头方向施力： 1mm/S ，弯曲距离： 1.5mm ，保持 $5 \pm 1\text{S}$ ，产品金属层无脱落。

Weld the product to the center part of the PCB with the thickness $1.6 \pm 0.2\text{mm}$ as the illustration shows, and keep exerting force arrow-ward on it at speed of 1mm/S , and hold for $5 \pm 1\text{S}$ at the position of 1.5mm bending distance, so far, any peeling off of the product metal coating should not be detected.

8.6 耐湿热特性 Moisture Proof

在温度为 $60 \pm 2^\circ\text{C}$ ，相对湿度 $90\sim 95\%$ 的恒温湿箱中放置 96 小时，在常温中恢复 1~2 小时后测试，符合表 7.1~7.6 规定。

The device should satisfy the electrical characteristics specified in paragraph 7.1~7.6 after exposed to the temperature $60 \pm 2^\circ\text{C}$ and the relative humidity $90\sim 95\%$ RH for 96 hours and 1~2 hours recovery time under normal condition.

8.7 高温特性 High Temperature Endurance

在温度为 $85 \pm 5^\circ\text{C}$ 的恒温箱中放置 24 ± 2 小时，在常温中恢复 1~2 小时后测试。符合表 7.1~7.6 规定。

The device should satisfy the electrical characteristics specified in paragraph 7.1~7.6 after exposed to temperature $85 \pm 5^\circ\text{C}$ for 24 ± 2 hours and 1~2 hours recovery time under normal temperature.

8.8 低温特性 Low Temperature Endurance

在温度为 $-40^\circ\text{C} \pm 5^\circ\text{C}$ 低温箱中放置 24 ± 2 小时后恢复 1~2 小时测试符合表 7.1~7.6 规定。

The device should also satisfy the electrical characteristics specified in paragraph 7.1~7.6 after exposed to the temperature $-40^\circ\text{C} \pm 5^\circ\text{C}$ for 24 ± 2 hours and to 2 hours recovery time under normal temperature.

8.9 温度循环 Temperature Cycle Test

在 -25°C 温度中保持 30 分钟，再在 $+85^\circ\text{C}$ 温度中保持 30 分钟，共循环 5 次后在常温中恢复 1~2 小时后测试符合表 7.1~7.6 规定。

The device should also satisfy the electrical characteristics specified in paragraph 7.1~7.6 after exposed to the low temperature -25°C and high temperature $+85^\circ\text{C}$ for 30 ± 2 min each by 5 cycles and 1 to 2 hours recovery time under normal temperature.

9 回流焊温度 Reflow Soldering Standard Condition

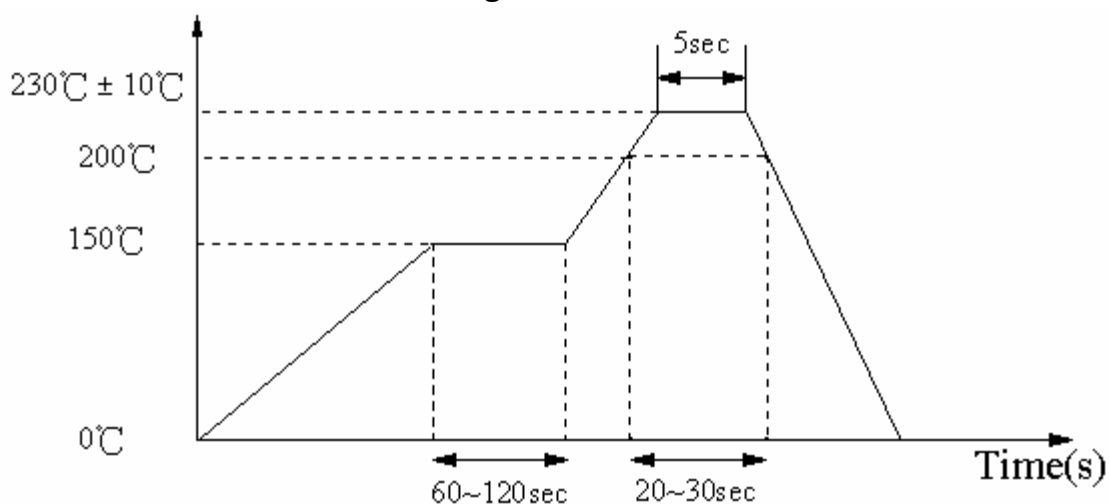

10 包装尺寸 (3216) Packaging and Dimensions

● Plastic Tape

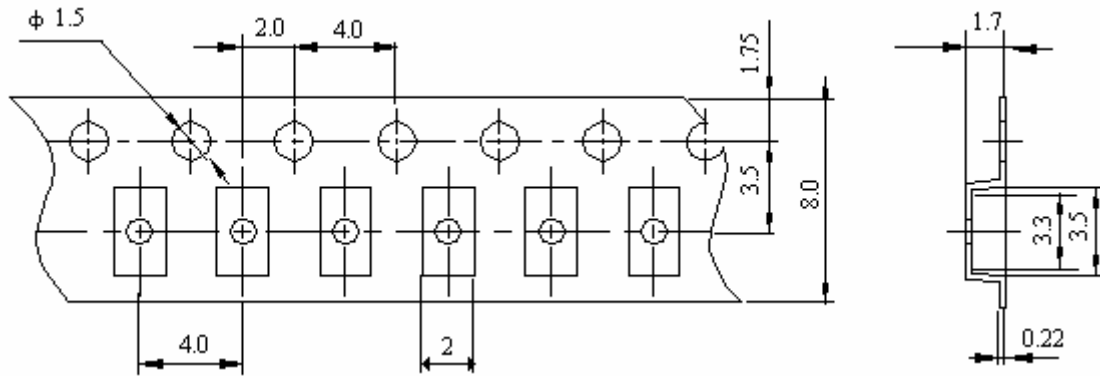

● Reel (2000 pcs/Reel)

