

HF116F-1

MINIATURE HIGH POWER RELAY



File No.:E134517



File No.:R50154722



File No.:CQC09002031231(DC type)



Features

- 30A switching capability
- 4kV dielectric strength (between coil and contacts)
- 3mm contact gap available
- UL insulation system: Class F available
- Environmental friendly product (RoHS compliant)
- Outline Dimensions: (50.5 x 32.9 x 36.0) mm

CONTACT DATA

Contact arrangement	1A	2A
Contact resistance	100mΩ max.(at 1A 24VDC)	
Contact material	AgSnO ₂ , AgCdO	
Contact rating (Res. load)	30A 240VAC 30A 277VAC	25A 240VAC 25A 277VAC
Max. switching voltage	277VAC	
Max. switching current	30A	25A
Max. switching power	8310VA	6925VA
Mechanical endurance	1 x 10 ⁷ OPS	
Electrical endurance	1 x 10 ⁵ OPS (See approval reports for more details)	

CHARACTERISTICS

Insulation resistance	1000MΩ (at 500VDC)	
Dielectric strength	Between coil & contacts	4000VAC 1min
	Between open contacts	2000VAC 1min
Operate time (at nomi. volt.)	30ms max.(DC type)	
Release time (at nomi. volt.)	30ms max.(DC type)	
Shock resistance	Functional	Standard:98m/s ² Pulse width 11ms W type:98m/s ² Pulse width 6ms
	Destructive	980m/s ² Pulse width 6ms
Vibration resistance	Standard:10H to 55Hz 1.5mm DA W type:10H to 55Hz 1.0mm DA	
Ambient temperature	-55°C to 70°C	
Humidity	5% to 85% RH	
Termination	PCB, QC, Screw	
Unit weight	Approx. 120g	
Construction	Dust protected	

Notes: 1) The data shown above are initial values.
2) Please find coil temperature curve in the characteristic curves below.
3) UL insulation system: Class F, Class B.

COIL

Coil power	DC type: Approx. 1.9W; AC type: Approx. 2.7VA
------------	--

COIL DATA

at 23°C

Nominal Voltage VDC	Pick-up Voltage VDC max.	Drop-out Voltage VDC min.	Max. Allowable Voltage VDC	Coil Resistance Ω
3	2.25	0.3	3.3	4.7 x (1±10%)
6	4.50	0.6	6.6	18.8 x (1±10%)
12	9.00	1.2	13.2	75 x (1±10%)
24	18.0	2.4	26.4	300 x (1±10%)
48	36.0	4.8	52.8	1200 x (1±10%)
100	75.0	10.0	110	5200 x (1±10%)
110	82.5	11.0	121	6300 x (1±10%)
200	150	20.0	220	21000 x (1±10%)

Nominal Voltage VAC	Pick-up Voltage VAC	Drop-out Voltage VAC	Max. Allowable Voltage VAC	Coil Resistance Ω
6	4.80	0.90	6.6	18.8 x (1±10%)
12	9.60	1.80	13.2	75 x (1±10%)
24	19.2	3.60	26.4	300 x (1±10%)
48	38.4	7.20	52.8	1200 x (1±10%)
120	96.0	18.0	132	5200 x (1±10%)
220	176	33.0	242	20800 x (1±10%)

SAFETY APPROVAL RATINGS

UL/CUL	AgSnO ₂	30A 277VAC 1.5HP 120VAC 3HP 240VAC 10A 120VAC Tungsten
	AgCdO	30A 277VAC 1.5HP 120VAC 3HP 240VAC 10A 120VAC Tungsten TV-10 120VAC
TÜV		27A 240VAC COSØ =0.8 25A 240VAC COSØ =0.4 25A 240VAC COSØ =1

Notes: Only some typical ratings are listed above. If more details are required, please contact us.



HONGFA RELAY

ISO9001, ISO/TS16949, ISO14001, OHSAS18001, IECQ QC 080000 CERTIFIED

2013 Rev. 1.01

ORDERING INFORMATION

HF116F-1 / 012 D A -1H T F W C (XXX)	
Type	
Coil voltage	DC: 3VDC to 200VDC AC: 6VAC to 220VAC
Coil voltage form	D: DC A: AC
Mounting	A: Mount P: PCB F: Flanged
Contact arrangement	1H:1 Form A 2H: 2 Form A
Contact material ¹⁾	T: AgSnO ₂ Nil: AgCdO
Insulation standard	F: Class F Nil: Class B
Contact Gap	W: 3.0mm Nil: Standard
Capacitor	C: With Capacitor(Only for AC) Nil: Without Capacitor
Customer special code	

Notes: 1) For the applications of motor load, capacitive load and high inrush current, AgSnO₂ contact material is recommended. For the applications of resistive load or low inductive load, AgCdO contact material is recommended.

OUTLINE DIMENSIONS, WIRING DIAGRAM AND PC BOARD LAYOUT

Unit: mm

Outline Dimensions

PCB Layout (Bottom view)

HF116F-1/□□□ -□ -P-1H-□

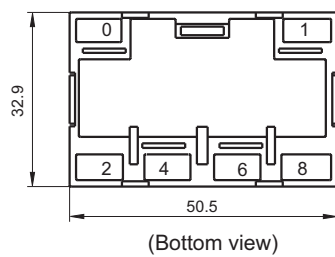

HF116F-1/□□□ -□ -P-2H-□

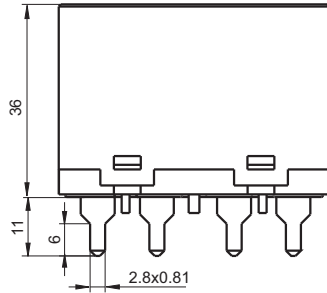
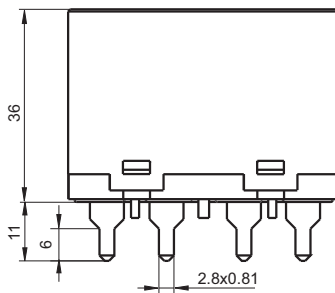
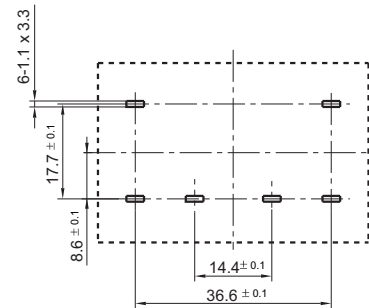
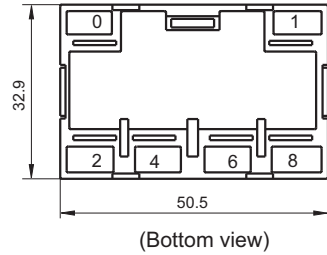

Outline Dimensions

HF116F-1/□□□□-□-F-1H-□

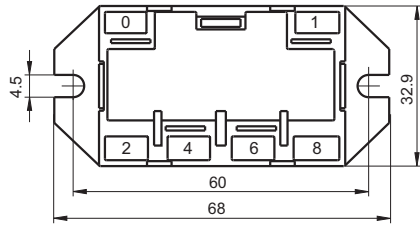

(Bottom view)

HF116F-1/□□□□-□-F-2H-□

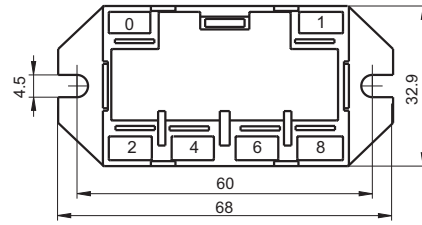

(Bottom view)

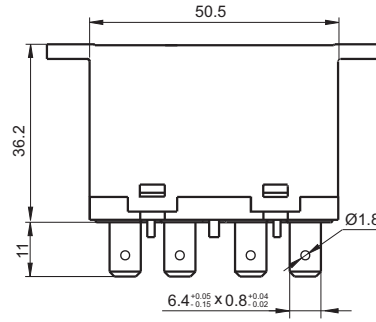
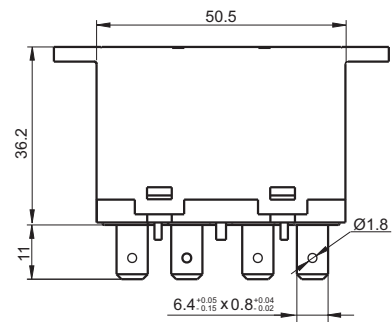

HF116F-1/□□□□-□-A-1H-□

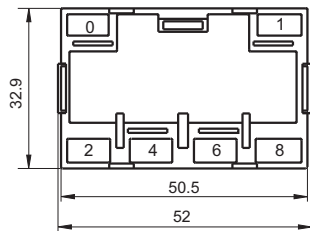

(Bottom view)

HF116F-1/□□□□-□-A-2H-□

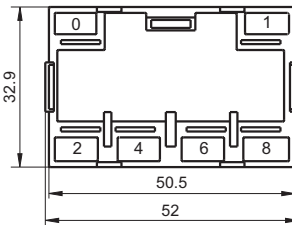

(Bottom view)

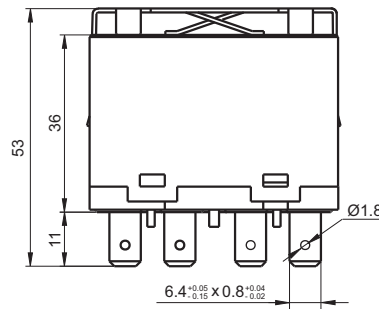
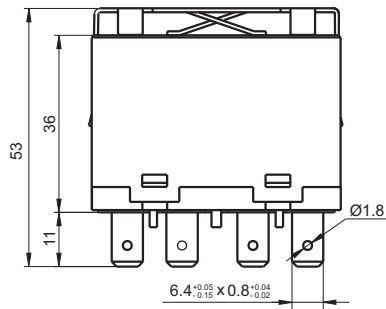

Mounting Holes

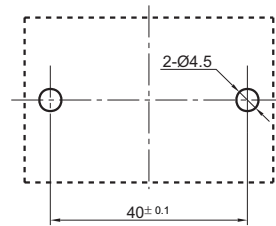

- Remark: 1) In case of no tolerance shown in outline dimension: outline dimension ≤ 1 mm, tolerance should be ± 0.2 mm; outline dimension > 1 mm and ≤ 5 mm, tolerance should be ± 0.3 mm; outline dimension > 5 mm, tolerance should be ± 0.4 mm.
 2) The tolerance without indicating for PCB layout is always ± 0.1 mm.

Wiring Diagram
(Bottom view)

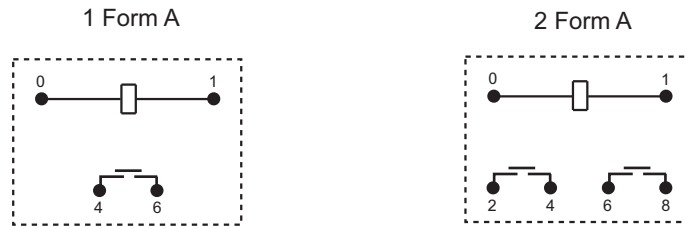

Coil Inner Circuit

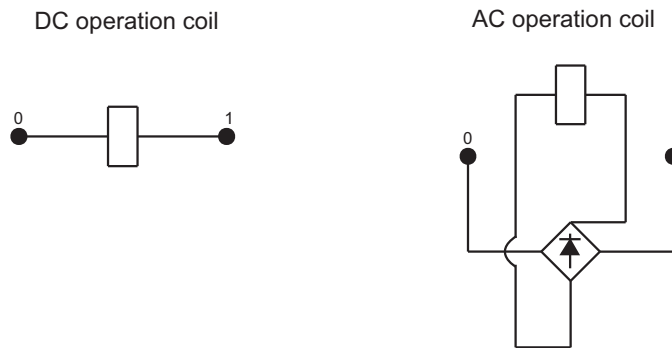

CHARACTERISTIC CURVES

MAXIMUM SWITCHING POWER

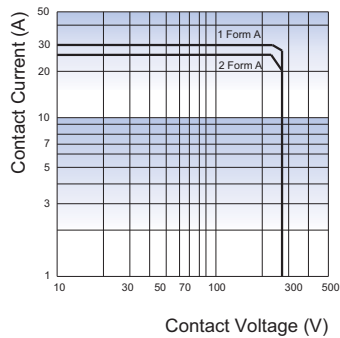

ENDURANCE CURVE

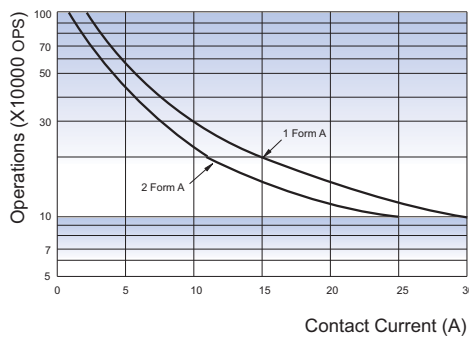

COIL TEMPERATURE RISE

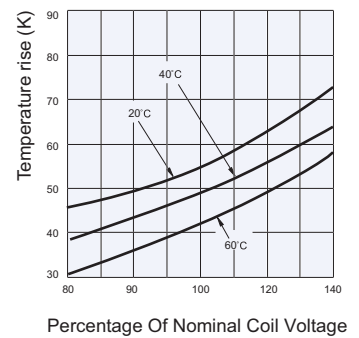

Disclaimer

This datasheet is for the customers' reference. All the specifications are subject to change without notice. We could not evaluate all the performance and all the parameters for every possible application. Thus the user should be in a right position to choose the suitable product for their own application. If there is any query, please contact Hongfa for the technical service. However, it is the user's responsibility to determine which product should be used only.

© Xiamen Hongfa Electroacoustic Co., Ltd. All rights of Hongfa are reserved.