

Approval Specification

Customer :

Product: Thick Film High Ohmic Chip Resistor

CR-02 / CR-03/CR-05

CR-06 / CR-10/CR-0A/CR-12

$\pm 1\%$ & $\pm 5\%$

Sizes : 0402 / 0603 / 0805

1206 / 1210 / 2010 / 2512

Approval Date. : _____

Customer Approval :

1. Features

- Reduced Size of Final Equipment
- Low Assembly Costs
- Higher Component and Equipment Reliability
- High Maximum Permissible Voltage

2. Applications

- Measuring Equipment
- Telecommunication Equipment
- Computers
- Televisio

3. Description

The resistors are constructed on the alumina substrate. Top electrodes are added to each end and connected with resistive paste that is applied to top surface of the alumina substrate. The resistive layer is made by resistive paste that is prepared to approach the nominal value. Laser trimming process makes the resistance value to meet the nominal value and within the tolerance.

The resistive layer is protected by primary overcoat and secondary overcoat. Marking on secondary overcoat let user to know the resistance value directly. The barrier layer is added to edge electrodes for plating with external electrode that is the main role makes the resistor mounted on PCB.

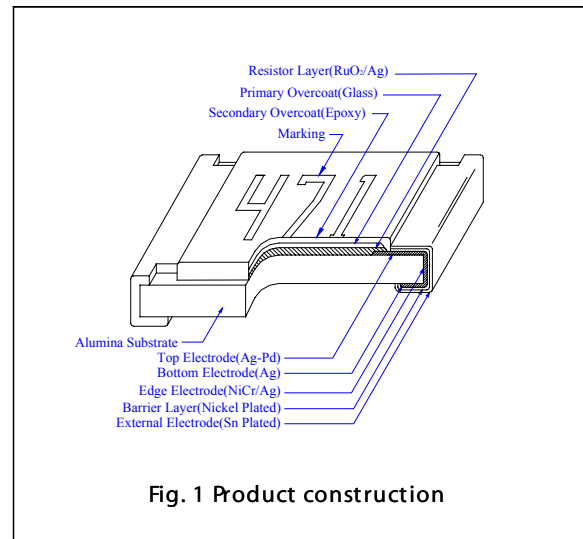

4. Quick Reference Data

Type name	CR-02	CR-03	CR-05	CR-06	CR-10	CR-0A	CR-12
Size code	0402	0603	0805	1206	1210	2010	2512
Resistance tolerance	±5%(E24 series) ; ±1%(E24, E96 series)						
Resistance range	±1%: 1MΩ~20MΩ ±5%: 11MΩ~39MΩ					±1%: 1MΩ~20MΩ ±5%: 11MΩ~20MΩ	
Temperature Coefficient of Resistance (ppm/°C)	±5%		±1%		±5%		±1%
R ≤ 20MΩ 22M ≤ R ≤ 39MΩ	±200 ±400		±200 -		±200 -		
Power rating (at 70°C)	1/16W	1/10W	1/8W	1/4W	1/3W	1/2W	1W
Max. operation voltage (DC or RMS)	50V	50V	150V	200V	200V	200V	200V
Max. overload voltage	100V	100V	300V	400V	400V	400V	400V
Jumper Rated current	1A	1A	2A	2A	2A	2A	2A
Climatic category (IEC 60068)	55/125/42	55/155/42					

5. Order information

Digits	1	2	3	4	5	6	7	8	9	10	11	12	13	14	
Order Code	C	R	-	0	5	J	-	7	-	-	-	1	2	M	
	Type Name CR-02: 0402 CR-03: 0603 CR-05: 0805 CR-06: 1206 CR-10: 1210 CR-0A: 2010 CR-12: 2512					Tolerance J : ?5% F : ?1%		Function code - : Normal L : Lead Free		Packaging 4 : 7" reel, Embossed tape, 4000 pcs/reel 6 : 7" reel, paper tape, 10000 pcs/reel 7 : 7" reel, paper tape, 5000 pcs/reel A : 10" reel, paper tape, 10000 pcs/reel B : 10" reel, paper tape, 20000 pcs/reel C : 13" reel, paper tape, 40000 pcs/reel D : 13" reel, paper tape, 20000 pcs/reel F : Bulk package - : Not Applicable				Resistance Value ---12M : 12M? ---18M : 18M? ---20M : 20M? ---24M : 24M?	

6. Functional description

Derating curve

For resistors operate in the ambient temperature over 70°C, loading power ratio will derate in accordance with following curve.

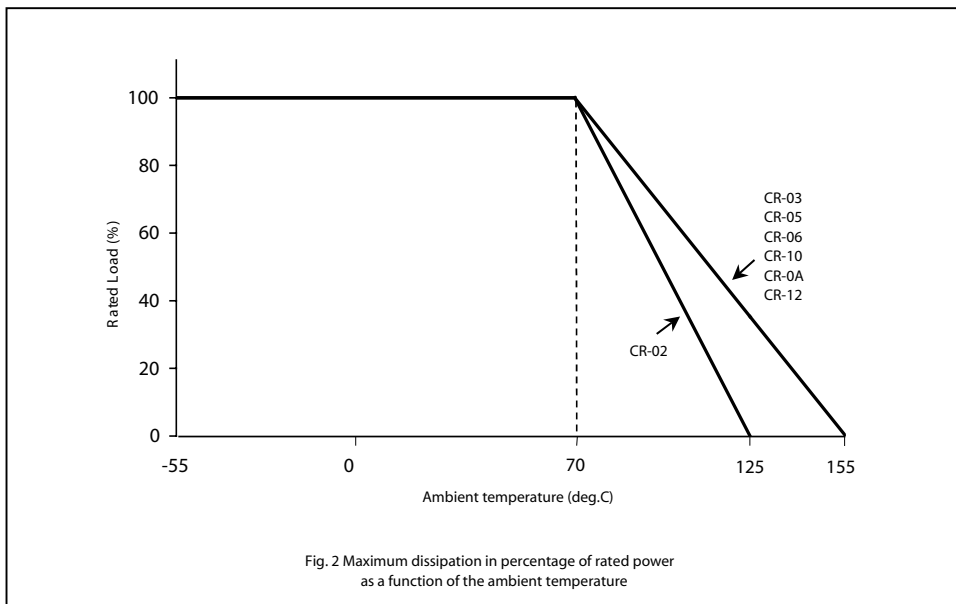

Soldering condition

TMTEC chip resistor can be applied in lead/tin and pure tin processes. Typical example of soldering processed that provide reliable joints without any damage are given in Figs. 3.

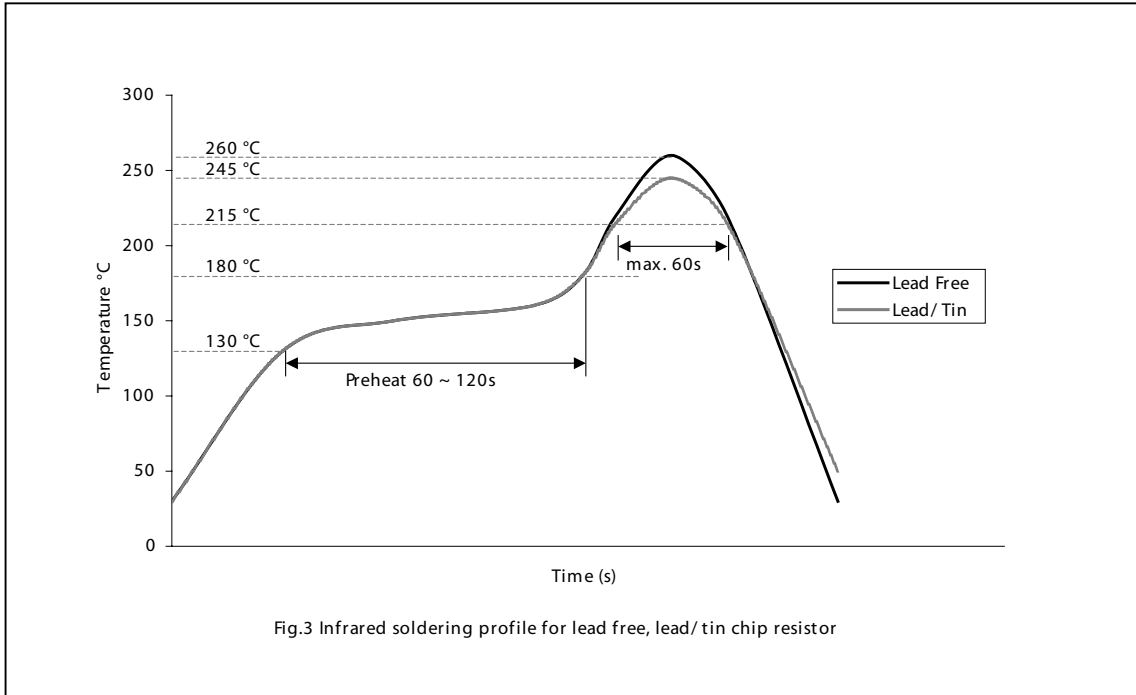

7. Mechanical Data

Mass per 1000 pcs

TYPE NAME	MASS (g)
CR-02	0.58
CR-03	2.02
CR-05	4.54
CR-06	8.84
CR-10	15.04
CR-0A	24.39
CR-25	40.01

Outline

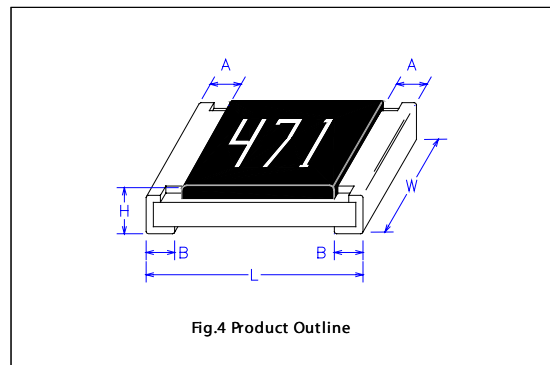

Dimension

Type	L (mm)	W (mm)	H (mm)	A (mm)	B (mm)
CR-02	1.00±0.05	0.50±0.05	0.35±0.05	0.20±0.10	0.25±0.10
CR-03	1.60±0.10	0.80±0.10	0.45±0.10	0.30±0.20	0.30±0.20
CR-05	2.00±0.10	1.25±0.10	0.50±0.10	0.35±0.20	0.40±0.20
CR-06	3.10±0.10	1.55±0.10	0.55±0.10	0.50±0.25	0.50±0.20
CR-10	3.20±0.20	2.60±0.15	0.55±0.10	0.50±0.25	0.50±0.20
CR-0A	5.00±0.20	2.50±0.15	0.55±0.10	0.60±0.25	0.50±0.20
CR-12	6.35±0.20	3.20±0.15	0.55±0.10	0.60±0.25	0.50±0.20

8. Test And Requirements

In table 3 the tests and requirements are listed with reference relevant clause of IEC 60115-1. A short description of the test procedure is given. Essentially all tests are carried out refer to the schedule of IEC 60115-8-1. The testing also covers the requirements specified by EIA.

Table 3 Test procedure and requirements

Test Item	Test Method	Test Condition	Requirement	
			±1%	±5%
Temperature Coefficient of Resistance(T.C.R.)	JIS C 5202 5.2 IEC 60115-1 4.8	-55°C~+125/+155 °C 20°C is the reference temperature	Within the specification	
Short Time Overload	JIS C 5202 5.5 IEC 60115-1 4.13	2.5 times RCWV or RCOV, for 5 seconds	±(1.0%+0.05%)	±(2.0%+0.05%)
Insulation Resistance	JIS C 5202 5.6 IEC 60115-1 4.6	RCOV for 1 minute	≥10G	
Voltage Proof	JIS C 5202 5.7 IEC 60115-1 4.7	1.42 times RCWV (RMS) for 1 minute	no breakdown or flashover	
Substrate Bending Test	JIS C 5202 6.1 IEC 60115-1 4.33	Bending once for 5 seconds 2010, 2512 size: 2mm Other size: 3mm	±(1.0%+0.05%)	±(1.0%+0.05%)
Resistance to soldering heat	JIS C 5202 6.4 IEC 60115 4.18	260±5°C for 10 seconds	±(0.5%+0.05%)	±(1.0%+0.05%)
Leaching	JIS C 5202 6.4 IEC 60115 4.18	260±5°C for 60 seconds	no leaching	
Solderability	JIS C 5202 6.5 IEC 60115-1 4.17	235±5°C for 2 seconds. lead free application: 245±3°C for 2 seconds.	>95% coverage	
Endurance at upper category temperature	JIS C 5202 7.2 IEC 60115-1 2.23.2	at +125/+155 °C for 1000 hrs	±(1.0%+0.05%)	±(1.5%+0.10%)
Rapid change of temperature	JIS C 5202 7.4 IEC 60115-1 4.19	-55°C to +125/+155 °C, 5 cycles	±(0.5%+0.05%)	±(1.0%+0.05%)
Damp heat with load	JIS 5202 7.9	40±2°C, 90~95% R.H. RCWV, for 1000 hrs with 1.5hrs "ON" and 0.5 hrs "OFF"	±(2.0%+0.10%)	±(3.0%+0.10%)
Endurance	JIS C 5202 7.10 IEC 60115-1 4.25.1	70±2°C, RCWV for 1000 hrs with 1.5 hrs "ON" and 0.5 hrs "OFF"	±(2.0+0.10%)	±(3.0+0.10%)

9. Packaging

Packaging Methods

Type (unit: piece)	Paper Tape			Embossed Tape	Bulk Cassette
	7" (178mm)	10" (254mm)	13" (330mm)	7"(178mm)	
CR-02	10000	20000	40000	-	50000
CR-03	5000	10000	20000	-	25000
CR-05	5000	10000	20000	-	10000
CR-06	5000	10000	20000	-	5000
CR-10	5000	10000	20000	-	-
CR-0A, CR-12	-	-	-	4000	-

Paper Tape

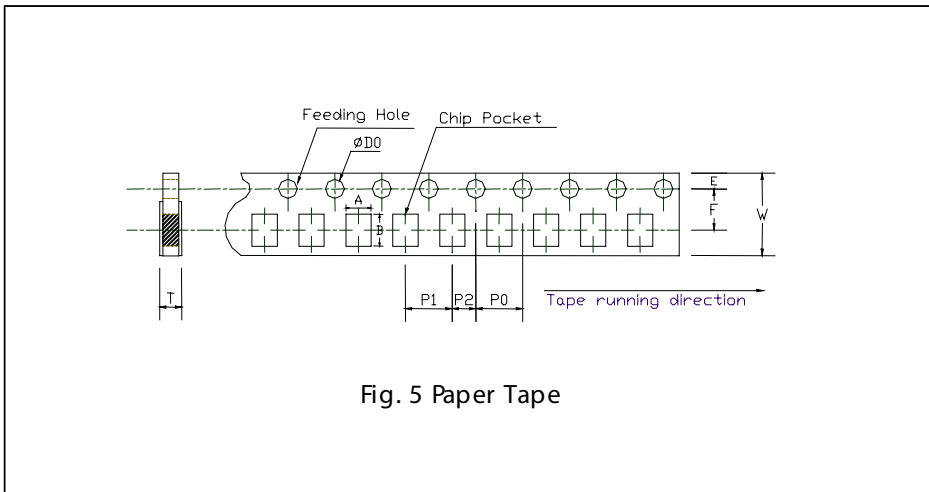

Type	A	B	W	E	F	P0	P1	P2	ϕ D0	T
CR-02	0.65±0.1	1.15±0.1	8.0±0.2	1.75±0.1	3.5±0.05	4.0±0.1	4.0±0.05	2.0±0.05	1.5 ^{+0.1/-0}	0.45±0.1
CR-03	1.10±0.1	1.90±0.1								0.70±0.1
CR-05	1.60±0.1	2.40±0.2								0.85±0.1
CR-06	1.90±0.1	3.50±0.2								0.85±0.1
CR-10	2.80±0.1	3.50±0.2								0.85±0.1

Unit: mm

Embossed Plastic Tape

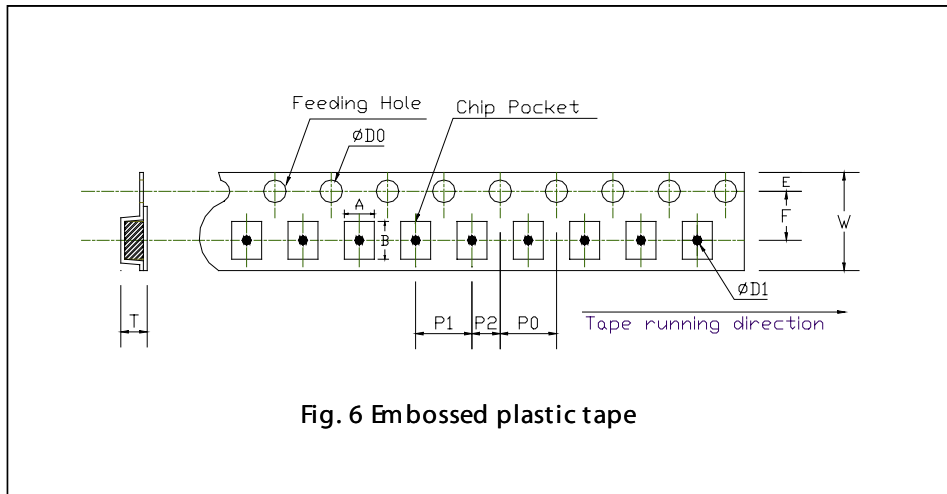

Type	A	B	W	E	F	P0	P1	P2	φ D0	φ D1	T
CR-0A	2.8±0.2	5.5±0.2	12±0.3	1.75±0.1	5.5±0.50	4.0±0.1	4.0±0.1	2.0±0.05	1.5 ^{+0.1/-0}	1.5 ^{+0.25/-0}	Max1.2
CR-12	3.5±0.2	6.7±0.2	12±0.3	1.75±0.1	5.5±0.50	4.0±0.1	4.0±0.1	2.0±0.05	1.5 ^{+0.1/-0}	1.5 ^{+0.25/-0}	Max1.2

Unit: mm

Reel Specification

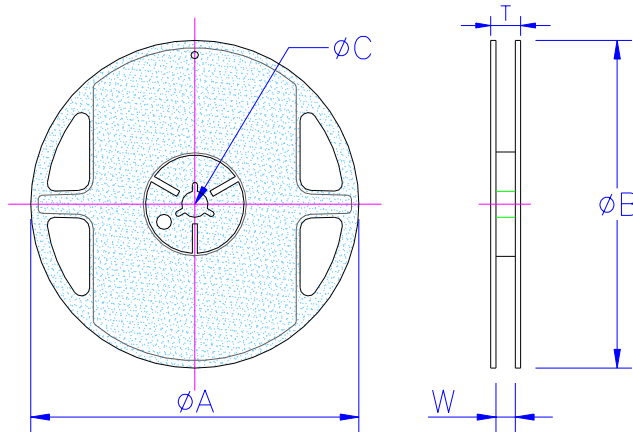

Unit:mmm

Style	Packing	Tape width	Reel Diameter	φ A	φ B	φ C	W	T
CR-02 CR-03 CR-05 CR-06 CR-10	Paper	8 mmm	7 inch	180 ^{+0/-3}	60 ^{+1/-0}	13.0±0.2	9.0±0.3	11.4±1
			10 inch	254±1	100±1	13.0±0.2	9.5±0.5	13.5±1
			13 inch	330±1	100±1	13.0±0.2	9.5±0.5	13.5±1
CR-0A CR-12	Embossed	12 mmm	7 inch	180 ^{+0/-3}	60 ^{+1/-0}	13.0±0.2	13.0±0.5	15.4±1

Label

The label put on each reel denoted with each products types, tolerance, resistance value, Q'ty, each Lot tracing no and barcode etc.

Example

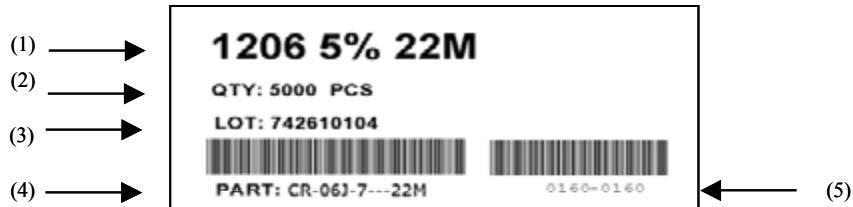

- (1) Type / Tolerance / Resistance value
- (2) Reel packing quantity
- (3) Lot Number
- (4) Part Number
- (5) Labeling control sequence

10. Revising History

Revision	Date	Change notification	Description
Rev.1	2004/7/30		New issue
Rev.2	2004/9/24		Added 1% Tolerance