

ME2-CO Carbon Monoxide Sensor Manual

Overview

ME2-CO electrochemical sensor detects the CO gas concentration by measuring current based on the electrochemical principle, which utilizes the electrochemical oxidation process of target gas on the working electrode inside the electrolytic cell, the current produced in electrochemical reaction of the target gas are in direct proportion with its concentration while following Faraday law, then concentration of CO could be get by measuring value of current.

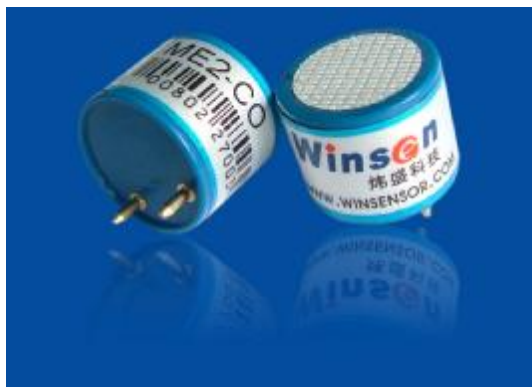

Features

- * Low consumption
- * High precision
- * High sensitivity
- * Extensive linear range
- * Strong anti-interference ability
- * Excellent repeatability and stability

Configuration

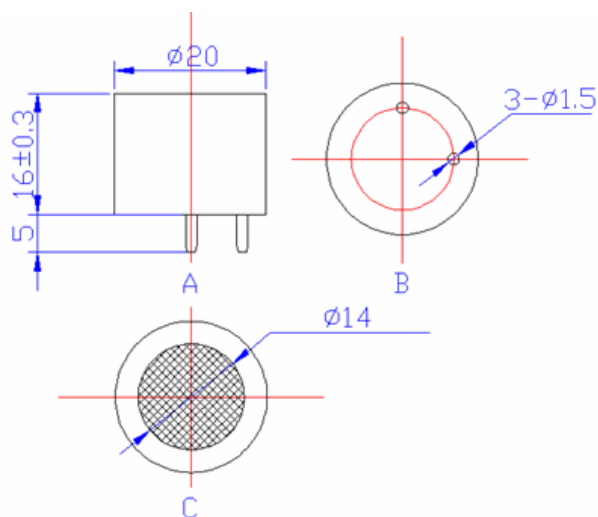

A—Left view B—upward view C—vertical view

W electrode — working electrode for oxidation reaction

C electrode — counter electrode for deoxidization reaction

Application

Widely use for the industrial application, especially the domestic use for CO concentration detection.

Technical specification

Items	Technical parameter
Detection Range	0—1000ppm
Max detecting bound	2000ppm
Detecting life	5 years
Sensitivity	0.015±0.005μA/ppm
Resolution	0.5ppm
Temperature range	-20°C—50°C
Pressure range	Normal atmosphere±10%
Response time (T90)	<50S
Humidity range	15%—90%RH
Zero shift (-20°C~+40°C)	≤10ppm
Stability (/ Month)	<10%
Load resistance (commend)	200Ω
Reproducibility	<10% output value
Output linearity	Linearity

Basic Testing Circuit

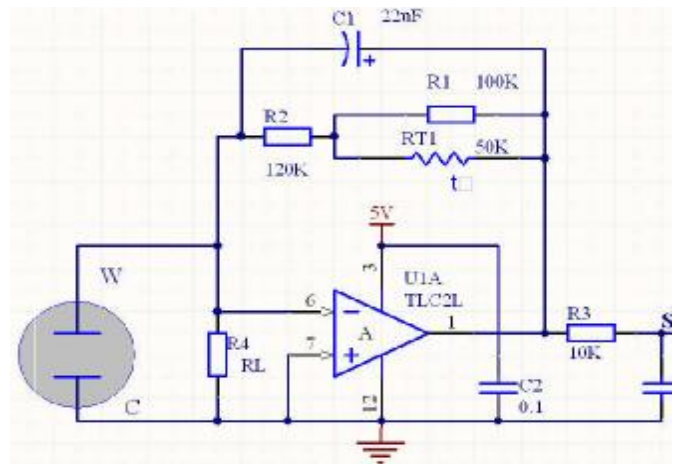

Features of sensitivity, response and output signal

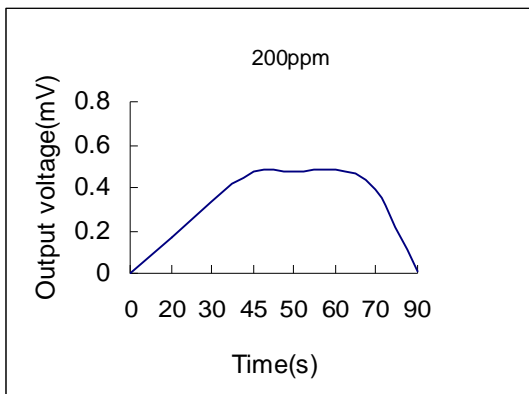

Data graph of concentration linearity features

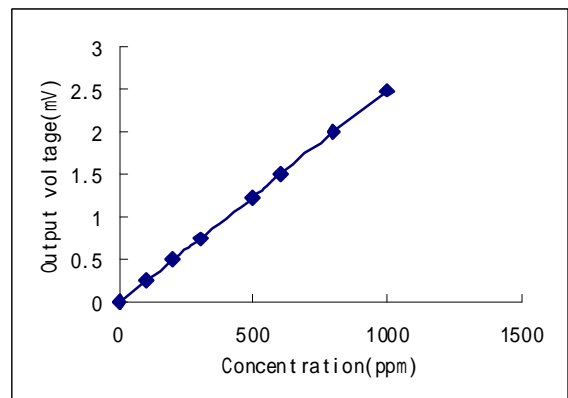

Sensitivity shift based on high-low temperature

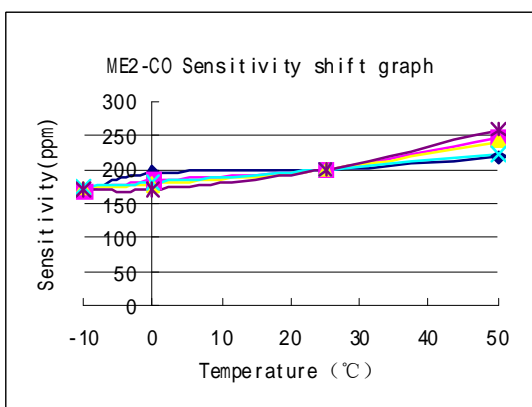

Zero shift based on high-low temperature

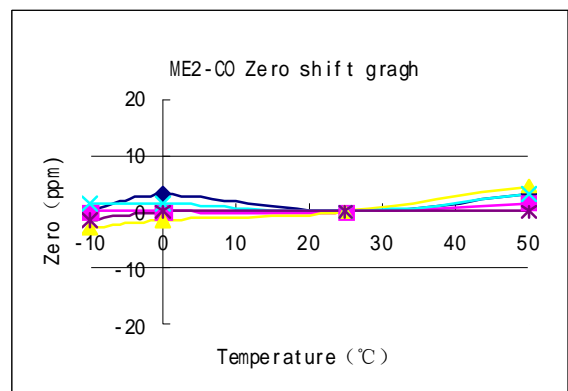

Anti-interference ability

ME2-CO is able to response to other gases besides the target gas, upon that listing the follow table for your information, which indicates response features of the sensor to the several normal interferential gases.

The data in the table is the representative response of the gas in certain concentration.

Gas	Concentration	ME2-CO
H ₂ S	100ppm	0ppm
SO ₂	20ppm	0ppm
H ₂	200ppm	40ppm
Ethene	100ppm	80ppm
NO	35ppm	6ppm
NO ₂	5ppm	0ppm
Ethanol	1000ppm	0ppm

Note

- n To avoid the sensor touching the organic solvent (silica gel and other cementing compound), dope, medicament, oil and high concentration gas.
- n All the electrochemical series gas sensor could be neither entirely packaged with resinous material, nor submerged in the pure oxygen environment, otherwise its performance will be damaged.
- n All the electrochemical series gas sensor can not have application in the corrosive gas environment, which will damage the sensor.
- n Please measure the gas sensitivity in the clean air.
- n To avoid the obverse target gas blowing intensively when measuring the gas sensitivity, otherwise the gas sensitivity will be extremely high.
- n Break off or curve the pin is forbidden.
- n The breathing vent should not be blocked or polluted, otherwise the sensitivity would be lower.
- n Prevent the sensor from excessive impaction or vibration.
- n Do not use the sensor if its shell is damaged.
- n It would be comparatively slow for the sensor resumes to the initial mode after using in the high concentration gas for long time.
- n Do not take apart the sensor optionally, or its electrolyte would be leaked to damage the sensor.
- n Working and reference electrode should be in short-circuit condition when sensor for stock.
- n Please aging the sensor at least 24 hours prior to use it, and the soldering installation is forbidden.