

1

2

3

4

A

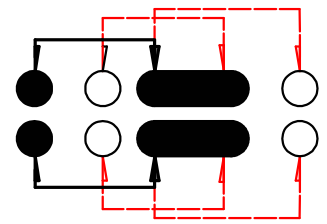
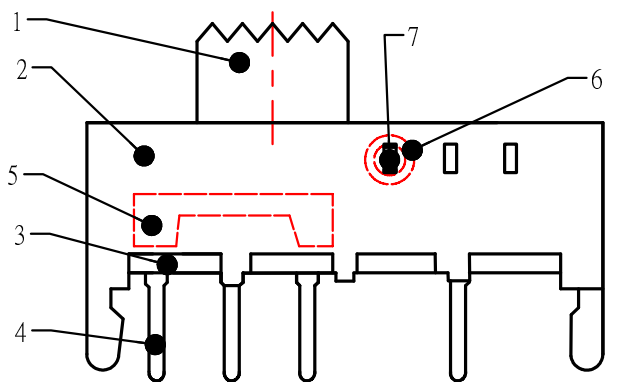
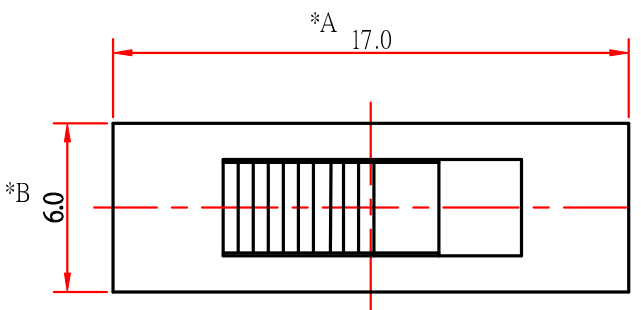

SCHMATIC

A

B

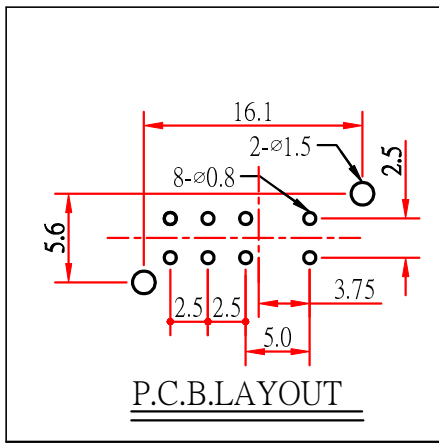
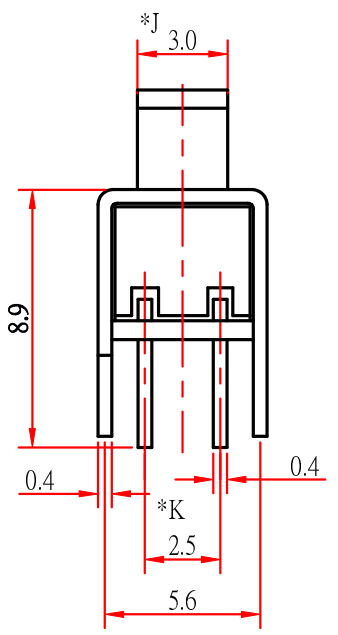
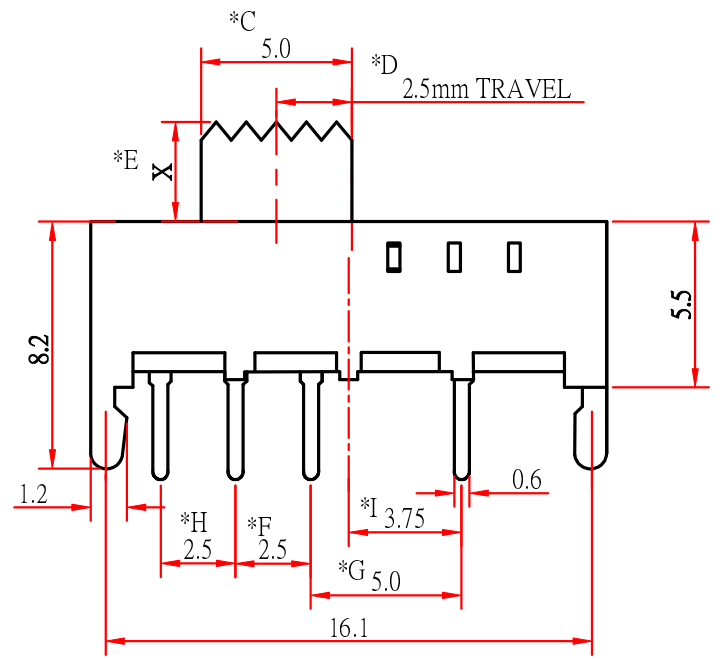

* CRITICAL DIMENSION

B

C

C

D

D

CHI FUNG ELECTRONICS CO.,LTD.

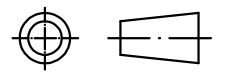

7	BALL	STEEL	2	NATURAL
6	SPRING	SPRING STEEL	1	NATURAL
5	CONTACT	C5210R-EH	2	Ag CLAD
4	TERMINAL	BRASS	8	Ag COATING
3	BASE	PHENOLIC RESIN	1	NATURAL
2	FRAME	STEEL STRIP	1	Ni COATING
1	KNOB	POM	1	BLACK
NO.	PART NAME	MATERIAL	QTY	FINISHING

SERIES : SLIDE SWITCH		DRAWING NO:	CF-ENL-SSV4149
PART NAME: SSV-23E05-GX		GENERAL TOLERANCE	
UNIT : M M	DWN.	WITHIN 0.XXmm?.15mm OVER 0.Xmm?.25mm	
SCALE : 4 : 1	CHK'D		
REV : A/0	APPD.		

1

2

3

4