



## LP2950/2951

## LINEAR INTEGRATED CIRCUIT

### 100 mA LOW-DROPOUT VOLTAGE REGULATOR

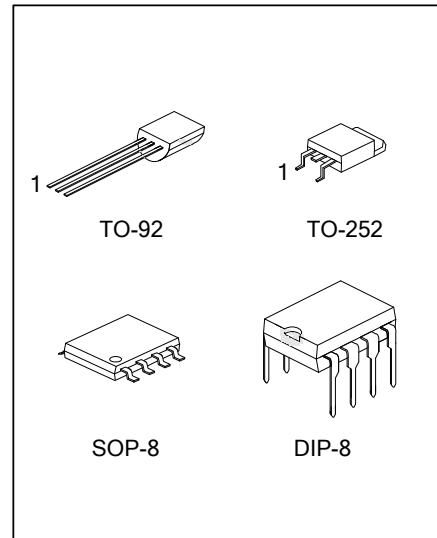
#### DESCRIPTION

The UTC **LP2950/2951** are monolithic integrated voltage regulators with low dropout voltage, and low quiescent current. It includes many features that suitable for different applications.

#### FEATURES

- \* Fixed output versions, 2.5V, 3V, 3.3V, 3.6V and 5V, are available.
- \* High accuracy output voltage.
- \* Extremely low quiescent current and dropout voltage.
- \* Extremely tight load and line regulation.
- \* Current and thermal limiting.
- \* Very low temperature coefficient.
- \* Logic controlled shutdown and err flog available for 8 pin package.
- \* Output voltage programmable for LP2951.

#### ORDERING INFORMATION



Lead-free: LP2950L-XX/LP2951L  
Halogen-free: LP2950G-XX/LP2951G

Ordering Number			Package	Packing
Normal	Lead Free	Halogen Free		
LP2950-xx-D08-T	LP2950L-xx-D08-T	LP2950G-xx-D08-T	DIP-8	Tube
LP2950-xx-S08-T	LP2950L-xx-S08-T	LP2950G-xx-S08-T	SOP-8	Tube
LP2950-xx-S08-R	LP2950L-xx-S08-R	LP2950G-xx-S08-R	SOP-8	Tape Reel
LP2950-xx-T92-B	LP2950L-xx-T92-B	LP2950G-xx-T92-B	TO-92	Tape Box
LP2950-xx-T92-K	LP2950L-xx-T92-K	LP2950G-xx-T92-K	TO-92	Bulk
LP2950-xx-TN3-T	LP2950L-xx-TN3-T	LP2950G-xx-TN3-T	TO-252	Tube
LP2950-xx-TN3-R	LP2950L-xx-TN3-R	LP2950G-xx-TN3-R	TO-252	Tape Reel
LP2951-D08-T	LP2951L-D08-T	LP2951G-D08-T	DIP-8	Tube
LP2951-S08-T	LP2951L-S08-T	LP2951G-S08-T	SOP-8	Tube
LP2951-S08-R	LP2951L-S08-R	LP2951G-S08-R	SOP-8	Tape Reel

Note: Pin Assignment: I:V<sub>IN</sub> O:V<sub>OUT</sub> G:GND

<p>LP2950L-xx-S08-R</p>	<p>(1) Packing Type (2) Package Type (3) Output Voltage Code (4) Lead Plating</p>	<p>(1) B: Tape Box, K: Bulk, R: Tape Reel, T: Tube (2) D08: DIP-8, S08: SOP-8, T92: TO-92 TN3: TO-252 (3) xx: refer to Output Voltage Code (4) G: Halogen Free, L: Lead Free, Blank: Pb/Sn</p>
-------------------------	---	--

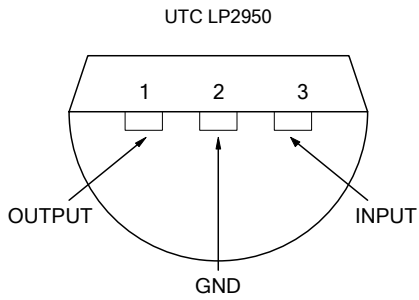
#### OUTPUT VOLTAGE CODE(For LP2950)

OUTPUT VOLTAGE	CODE
2.5V	25
3.0V	30
3.3V	33
3.6V	36
5.0V	50

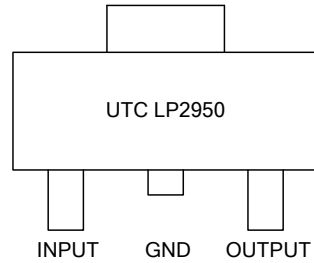
# LP2950/2951

## LINEAR INTEGRATED CIRCUIT

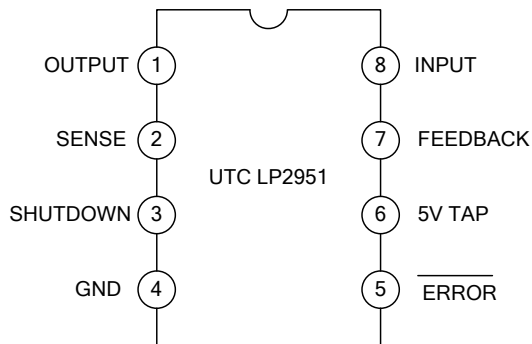
### PIN CONFIGURATIONS



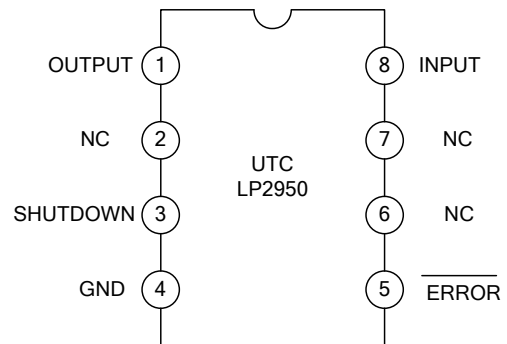
TO-92 Plastic Package Bottom View



SOT-252 Package

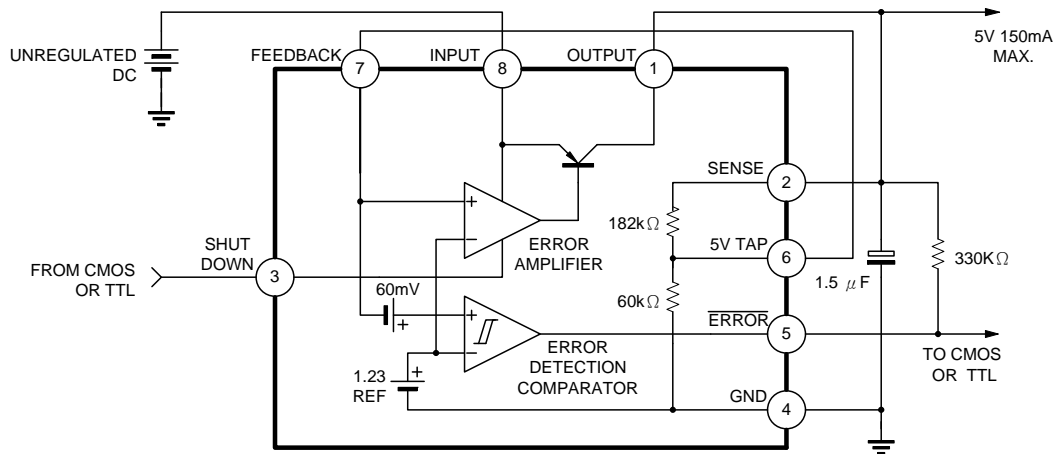


SOP-8 OR DIP-8 PACKAGE FOR UTC LP2951



SOP-8 OR DIP-8 PACKAGE FOR UTC LP2950

### BLOCK DIAGRAM



FOR UTC LP2951

### ■ ABSOLUTE MAXIMUM RATINGS

PARAMETER	SYMBOL	RATINGS	UNIT
Supply Voltage	$V_{CC}$	-0.3 ~ +30	V
Feedback Voltage	$V_{FB}$	-1.5 ~ +30	V
Shutdown Voltage	$V_{SHDN}$	-0.3 ~ +30	V
Power Dissipation	$P_D$	Internally Limited	W
Operation Junction Temperature	$T_J$	-40 ~ +125	°C
Storage Temperature	$T_{STG}$	-65 ~ +150	°C

Note: Absolute maximum ratings are those values beyond which the device could be permanently damaged. Absolute maximum ratings are stress ratings only and functional device operation is not implied.

### ■ THERMAL DATA

PARAMETER	SYMBOL	RATING	UNIT
Junction-to-Ambient	TO-92	160	°C/W
	TO-252	92	
	SOP-8	180	
	DIP-8	105	
Junction-to-Case	TO-92	83	°C/W
	TO-252	6	
	SOP-8	45	

### ■ ELECTRICAL CHARACTERISTICS ( $T_J=25^\circ\text{C}$ , $V_{IN}=6\text{V}$ , $I_L=100\mu\text{A}$ , $C_L=1\mu\text{F}$ , unless otherwise specified.)

#### For All Version:

PARAMETER	SYMBOL	TEST CONDITION	MIN	TYP	MAX	UNIT
Output Voltage	$V_{OUT}$	$T_J=25^\circ\text{C}$ (Note 1)	$V_{OUT}\times 0.98$	$V_{OUT}$	$V_{OUT}\times 1.02$	V
		$-25^\circ\text{C}\leq T_J\leq +85^\circ\text{C}$ (Note 1)	$V_{OUT}\times 0.98$	$V_{OUT}$	$V_{OUT}\times 1.02$	V
Output Voltage	$V_{OUT}$	$100\mu\text{A}\leq I_L\leq 100\text{mA}$ , $T_J\leq T_J(\text{max})$	$V_{OUT}\times 0.98$	$V_{OUT}$	$V_{OUT}\times 1.02$	V
Output Voltage Temperature Coefficient	$TcV_o$		20		100	ppm/°C
Line Regulation	$\Delta V_{OUT}$	$6\text{V}\leq V_{IN}\leq 30\text{V}$	0.03	0.1	0.2	%
Load Regulation	$\Delta V_{OUT}$	$100\mu\text{A}\leq I_L\leq 100\text{mA}$	0.04	0.1	0.2	%
Dropout Voltage	$V_D$	$I_L=100\mu\text{A}$	50	80	150	mV
		$I_L=100\text{mA}$ (Note 2)	380	450	600	
Ground Current	$I_G$	$I_L=100\mu\text{A}$	75	120	140	$\mu\text{A}$
		$I_L=100\text{mA}$	8	12	14	mA
Dropout Ground Current		$V_{IN}=4.5\text{V}$ , $I_L=100\mu\text{A}$	110	170	200	$\mu\text{A}$
Current Limit	$I_{LIMIT}$	$V_{OUT}=0$	160	200	220	mA
Output Noise (10Hz ~ 100KHz) (Bypass=0.01 $\mu\text{F}$ pins 7 to 1 (LP2951))	eN	$C_L=1\mu\text{F}$			430	$\mu\text{V}$
		$C_L=200\mu\text{F}$			160	
		$C_L=3.3\mu\text{F}$			100	

### ■ ELECTRICAL CHARACTERISTICS(Cont.)

#### For UTC LP2951 8-Pin Version Only

PARAMETER	SYMBOL	TEST CONDITION	MIN	TYP	MAX	UNIT	
Reference Voltage	$V_{REF}$		1.22	1.235	1.25	V	
Reference Voltage	$V_{REF}$	Over temperature(Note 4)	1.19		1.27	V	
Feedback pin Bias Current	$I_{FB}$			20	40	nA	
Reference Voltage Temperature Coefficient	$V_{REF(TC)}$			50		ppm/°C	
Feedback Bias Current Temperature Coefficient	$I_{FB(TC)}$			0.1		nA/°C	
<b>Error Comparator</b>							
Output Leakage Current	$I_{O(LEAK)}$	$V_{OH}=30V$			1	$\mu A$	
Output Low Voltage	$V_{OL}$	$V_{IN}=4.5V, I_{OL}=400\mu A$			250	mV	
Threshold Voltage	Upper	$V_{THU}$ (Note 3)	3.2			%VO	
	Lower	$V_{THL}$ (Note 3)			7.6	%VO	
Hysteresis	$V_{HYS}$	(Note 3)		15		mV	
<b>Shutdown Input</b>							
Input Logic Voltage	Low	$V_{IL}$	Regulator ON		1.3	0.70	V
	High	$V_{IH}$	Regulator OFF	2.0			
Shutdown Pin Input Current	$I_{SHDN}$	$V_{SHDN}=2.4V$		30	50	$\mu A$	
		$V_{SHDN}=30V$		450	600	$\mu A$	
Regulator Output Current Shutdown	$I_{DFF}$	$V_{SHDN} \geq 2V, V_{IN} \leq 30V, V_{OUT}=0$ Feedback pin tied to 5V Tap.		3	10	$\mu A$	

Note: 1. Additional conditions for 8-pin versions are FB pin tied to  $5V_{TAP}$ , Output tied to Sense ( $V_{OUT}=5V$ ) and  $V_{SHDN} \leq 0.8V$ .

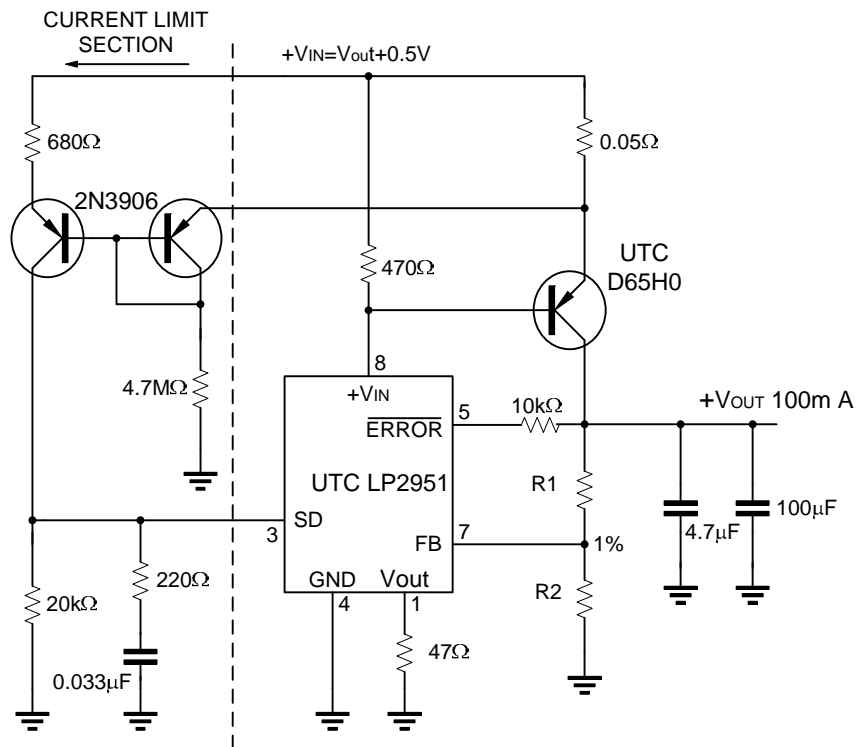
2. Dropout Voltage is defined as the input to output differential at which the output voltage drops 100mV below its nominal value measured at 1V differential.

3. Comparator thresholds are expressed in terms of percentage value of voltage output.

4.  $V_{REF} \leq V_{OUT} \leq (V_{IN}-1V)$ ,  $2.3V \leq V_{IN} \leq 30V$ ,  $100\mu A \leq I_L \leq 100mA$ ,  $T_J \leq T_{J(MAX)}$

■ TYPICAL APPLICATION CIRCUIT

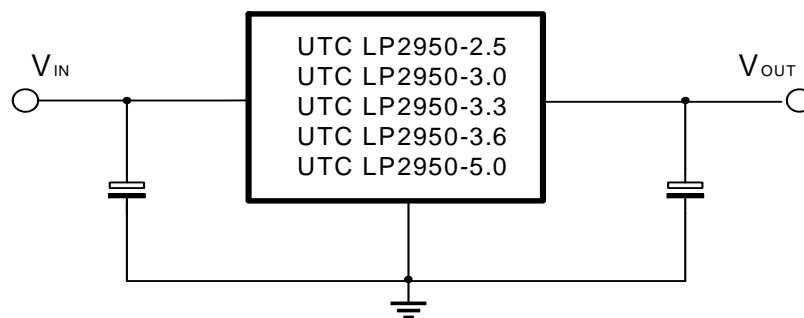
**10 Ampere Low Dropout Regulator**



$$V_{OUT} = 1.23V * (1 + R1/R2)$$

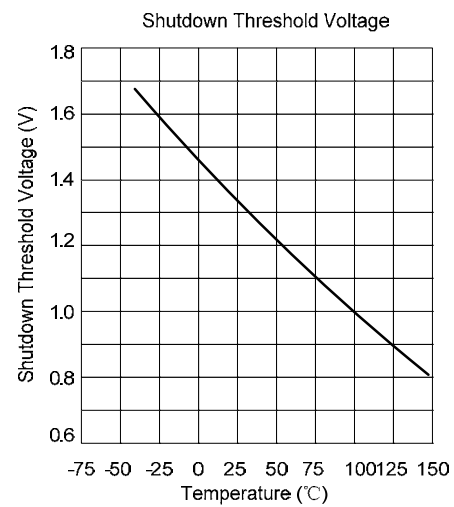
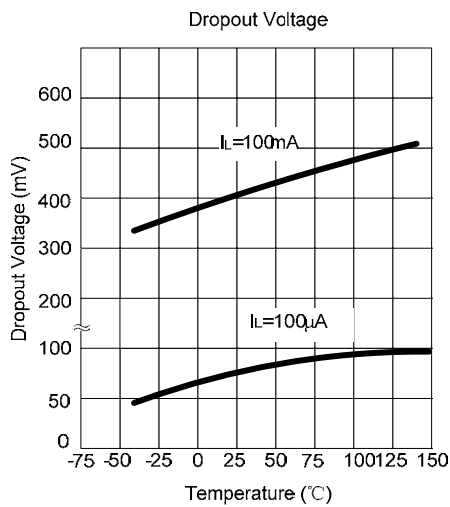
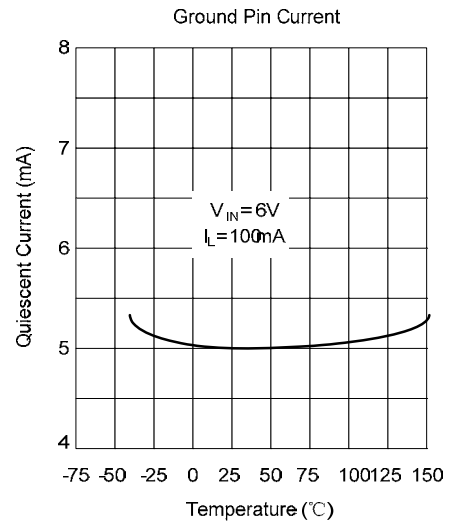
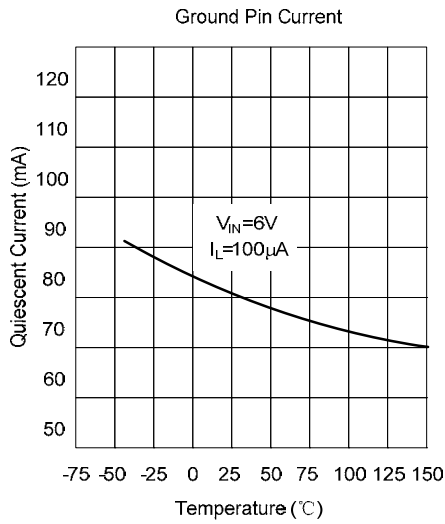
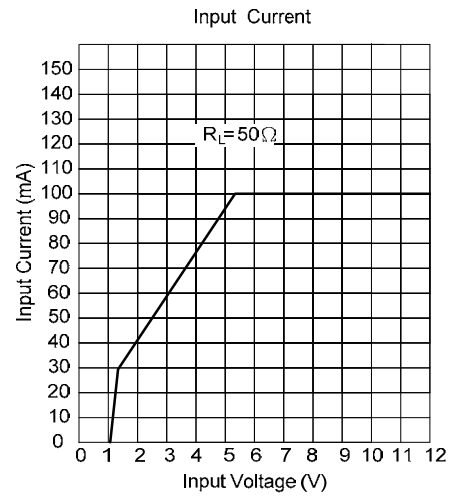
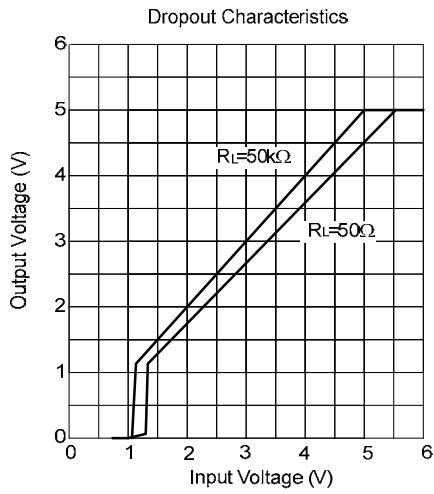
For 5V output use internal resistors. Wire pin 6 to 7 and wire pin 2 to +Vout

**Fig.1**

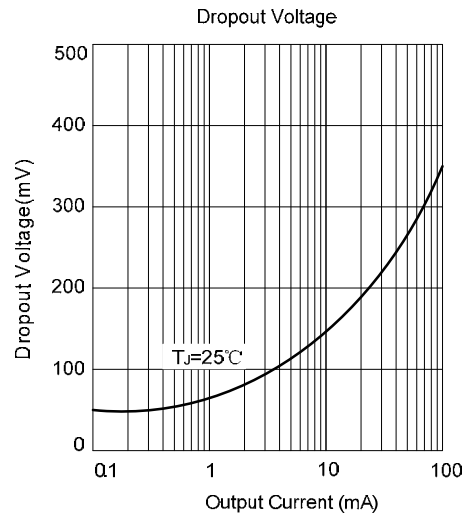
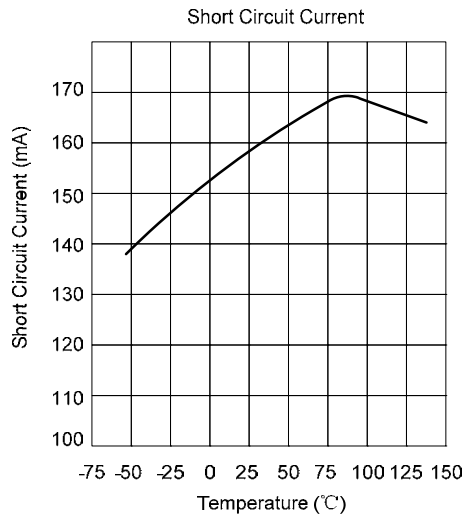


**Fig.2**

## TYPICAL CHARACTERISTICS



■ TYPICAL CHARACTERISTICS(Cont.)



UTC assumes no responsibility for equipment failures that result from using products at values that exceed, even momentarily, rated values (such as maximum ratings, operating condition ranges, or other parameters) listed in products specifications of any and all UTC products described or contained herein. UTC products are not designed for use in life support appliances, devices or systems where malfunction of these products can be reasonably expected to result in personal injury. Reproduction in whole or in part is prohibited without the prior written consent of the copyright owner. The information presented in this document does not form part of any quotation or contract, is believed to be accurate and reliable and may be changed without notice.