

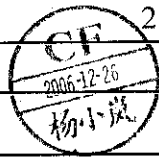

SPECIFICATION 规格书		规格书编号	CF-SPE-PS001A-3
		版 本	A / 0
		页 次	1 / 3
		确 认 日 期	
WRITTEN 制定		APP'D审批	
MODEL SERIES NAME 系列名称:		PUSH SWITCH	
MODEL NO 产品型号:			
1.RATING 额定值:		DC 6V 0.35A	
2.FUNCTION 接触型式:		2P2T	
3.TIMING 时间特性		NON-SHORTING	
4.ELECTRICAL CHARACTERISTICS 电气性能规格:			
ITEM 项目	TEST CONDITIONS 测试条件	PERFORMANCE 表现	
4.1	CONTACT RESISTANCE 接触电阻 MEASURED AT SMALL CURRENT (100mA OR LESS) 1000Hz. 在微小电流(100mA)以下测试.	50mΩ Max 50毫欧以下	
4.2	INSULATION RESISTANCE 绝缘电阻 APPLY A VOLTAGE OF 500V DC FOR 1 MIN. TO FOLLOWING PORTIONS AFTER WHICH MEASUREMENT SHALL BE MADE: (1) BETWEEN BODY AND CONDUCTOR. (2) BETWEEN INDIVIDUAL TERMINALS AND FRAME. 输入 500V DC电压1分钟,按以下接触方法测试: (1)接触端子之间. (2)胶座体与排脚之间.	100MΩ MIN. 100兆欧以上	
4.3	DIELECTRIC STRENGTH 耐电压 AC 500V rms(50-60Hz)FOR 1 MIN TRIP CURRENT:0.5 mA (1)BETWEEN TERMINALS. (2)BETWEEN INDIVIDUAL TERMINALS AND FRAME. 输入AC 500V (50-60Hz) 电压,1分钟感应电流为0.5mA.按以下接触方法测试: (1)接触端子之间. (2)插座体与端子之间.	NO DAMAGE TO PARTS ARCING, OR BREAKDOWN ETC. 没有绝缘破坏等异常.	
5	PRACTICAL TEMPERATURE RANGE 使用温度范围	-40℃~+85℃ 在-40℃~+85℃ 温度内使用	
6	STANDARD ATMOSPHEIC CONDITIONS 测试标准状态	UNLESS OTHERWISE SPECIFIED. THE STANDARD RANGE OF ATMOSPHERIC CONDITIONS FOR MAKING MEASUREMENTS AND TESTS ARE AS FOLLOWS: (1)AMBIENT TEMPERATURE:5℃ TO 35℃. (2)RELATIVE HUMIDITY:45% TO 85%. (3)AIR PRESSURE:80Kpa TO 106Kpa. 在没有指定的情况下测试温度,湿度,气压如下: (1)温度为5℃-35℃. (2)湿度为45%-85%. (3)气压为80Kpa-106Kpa.	



SPECIFICATION 规格书		规格书编号	CF-SPE-PS001A-3
		版 本	A / 0
		页 次	2 / 3
		确认日期	
7.MECHANICAL CHARACTERISTICS 机械性能规格:			
ITEM 项目	TEST CONDITIONS 测试条件	PERFORMANCE 表现	
7.1	OPERATION FORCE 作动力	180gf±80gf	
7.2	TERMINAL STRENGTH 端子强度	A STATIC LOAD OF 300gf SHALL BE APPLIED TO THE TIP OF THE TERMINAL FOR 1 MIN. IN ANY DIRECTION. 在任意一个方向的先端加上300gf力度测试,时间为1分钟.	ELECTRICAL CHARACTERISTICS SHALL BE SATISFIED WITHOUT DAMAGE OR EXCESSIVE LOOSENESS OF TERMINALS 在排脚中没有裂开,松动等异常,满足于机械,电器性能.
7.3	LIFE TEST 寿命测试	1.ENDURANCE WITHOUT LOADING: AN ACTUATOR SHALL BE SUBJECT TO 10,000CYCLES AT A SPEED OF 25~30 CYCLES FOR 1 MIN. 无负荷: 操作者以每分钟25~30次的频率作10,000回之无负荷测试. 2.ENDURANCE WITH LOADING: AN ACTUATOR SHALL BE SUBJECT TO 5,000CYCLES AT A SPEED OF 25~30 CYCLES FOR 1 MIN. 负荷: 操作者以每分钟25~30次的频率作5,000回之负荷测试.	(1)CONTACT RESISTANCE SHALL BE 80mΩ MAX. 接触电阻不能超过80毫欧. (2)MECHANICAL AND ELECTRICAL CHARACTERISTICS SHALL BE SATISFIED. 其它满足于机械,电器性能.
8.DURABILITY 耐久性:			
ITEM 项目	TEST CONDITIONS 测试条件	PERFORMANCE 表现	
8.1	SOLDERABILITY TEST 可焊性试验	THE TOP OF THE TERMINALS SHALL BE DIPPED 2mm IN THE SOLDER BATH OF 230±10°C FOR 3±0.5 SECONDS. 端子顶部被浸入锡焊池中2mm深,温度为230±10°C,时间为3±0.5秒.	AREA OF SOLDERING NEED BE SMOOTH AND GOOD PERFORMANCE. 焊锡部分粘锡均匀,饱满,锡面平滑.
8.2	RESISTANCE TO SOLDERING HEAT TEST 耐焊性试验	SOLDER BATH METHOD: SOLDER TEMPERATURE 260±5°C,IMMERSION TIME 3±0.5 SEC,IMMERSION DEPTH UP TO THE SURFACE OF THE BOARD. DIMENSIONS OF COMPONENT HOLES IN THE PRINTED WIRING BOARD SHALL BEING ACCORDANCE WITH THOSE SPECIFIED IN THIS SPECIFICATION. 焊炉焊接的时候温度控制在 260±5°C,过炉时间3±0.5秒.	WITHOUT DEFORMATION OF CASE OR EXCESSIVE LOOSENESS OF TEMINALS ELECTRICAL CHARACTERISTICS SHALL BE SATISFIED. 本体无变形,能满足于机械,电器性能.



SPECIFICATION 规格书		规格书编号	CF-SPE-PS001A-3
		版本	A / 0
		页次	3 / 3
		确认日期	2006-12-28 柳小波
ITEM 项目	TEST CONDITIONS 测试条件	PERFORMANCE 表现	
8.3	HEAT TEST 耐热试验 THE SWITCH SHALL BE STORED AT A TEMPERATURE OF $85 \pm 2^{\circ}\text{C}$ FOR 96 HOURS. THEN THE SWITCH SHALL BE MAINTAINED AT STANDARD ATMOSPHERIC CONDITION FOR 1 HOUR AFTER WHICH MEASUREMENT SHALL BE MADE. 放置在温度 $85 \pm 2^{\circ}\text{C}$ 中测试96小时后,再放置正常室温中1小时来测定.	THERE SHALL BE NO DEFORMATION OR CRACKS IN MOLDED PART. 外观无异常,满足于机械,电器性能.	
8.4	COLD TEST 耐冷试验 THE SWITCH SHALL BE STORED AT A TEMPERATURE OF $-40 \pm 3^{\circ}\text{C}$ FOR 96 HOURS, THEN THE SWITCH SHALL BE MAINTAINED AT STANDARD ATMOSPHERIC CONDITION FOR 1 HOUR AFTER WHICH MEASUREMENT SHALL BE MADE. 放置在温度 $-40 \pm 3^{\circ}\text{C}$ 中96小时后,再放置常温中1小时来进行测试.		
8.5	HUMIDITY TEST 潮湿试验 THE SWITCH SHALL BE STORED AT A TEMPERATURE OF $40 \pm 2^{\circ}\text{C}$ AND A HUMIDITY OF 90% TO 95% FOR 96 HOURS. THEN THE SWITCH SHALL BE MAINTAINED AT STANDARD ATMOSPHERE CONDITION FOR 1 HOUR AFTER WHICH MEASUREMENT SHALL BE MADE. 放置 $40 \pm 2^{\circ}\text{C}$ 试验的相对湿度为90%-95%环境中96小时后,再将样板放在正常环境1小时后进行测试.		

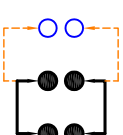
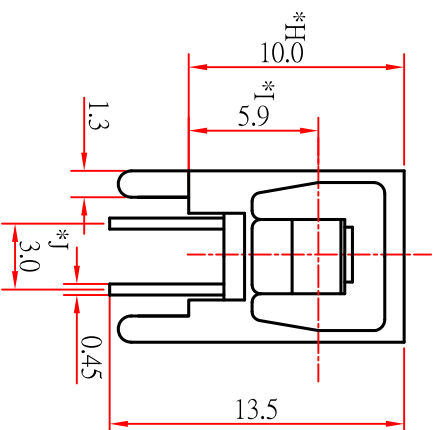
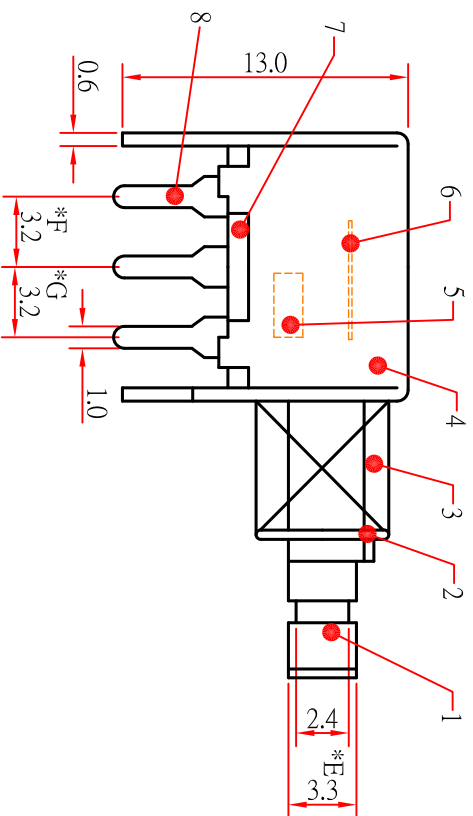
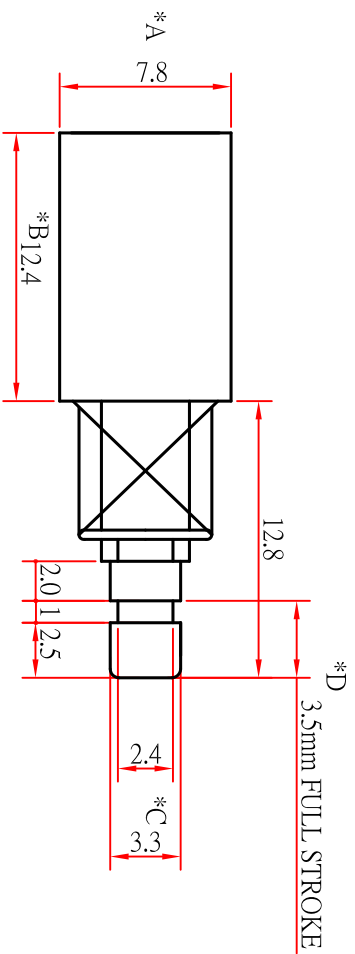

SCHEMATIC

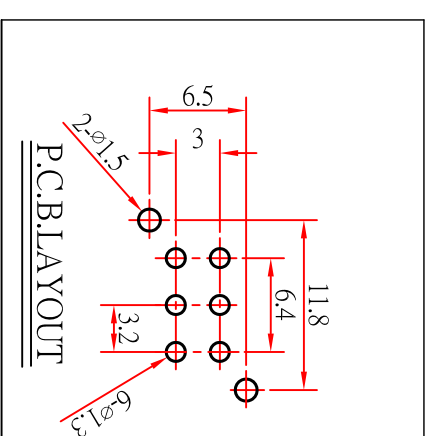

P.C.B.LAYOUT

* CRITICAL DIMENSION

CHI FUNG ELECTRONICS CO.,LTD.

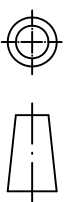

SERIES : PUSH SWITCH		DRAWING NO: CF-ENI-PS4060-1	
PART NAME: PS-22F03NL		GENERAL TOLERANCE	
UNIT : M.M	DWN.	WITHIN 0.XXmm±0.15mm	
SCALE : 3 : 1	CHK'D	OVER 0.Xmm±0.25mm	
REV : A/0	APP'D.		

NO.	TERMINAL	MATERIAL	QTY	FINISHING
8	BASE	BRASS	6	Ag COATING
7	SPRING PLATE	PHENOLIC RESIN	1	NATURAL
6	CONTACT	PBS	1	NATURAL
5	FRAME	C5210R-EH	2	Ag CLAD
4	SPRING	STEEL STRIP	1	Ni COATING
3	LOCK PLATE	STEEL STRIP	1	NATURAL
2	KNOB	STEEL STRIP	1	Ni COATING
1	PART NAME	POM	1	BLACK