

PARTS LIST

| NO | PARTS NAME | MATERIAL | SPECIFICATION | QTY | FINISH |
|----|------------|-----------|---------------|-----|----------|
| 1 | COVER | STAINLESS | SUS 301 | 1 | |
| 2 | DUST COVER | PI | | 1 | |
| 3 | CONTACT | STAINLESS | Ag-SUS 301 | 1 | Ag CLAD |
| 4 | TERMINAL | PBSR | C5210R | 1 | Ag PLATE |
| 5 | CASE | LCP | | 1 | |

**SMD REFLOW PATTERN
(TOLERANCE : N/S)**

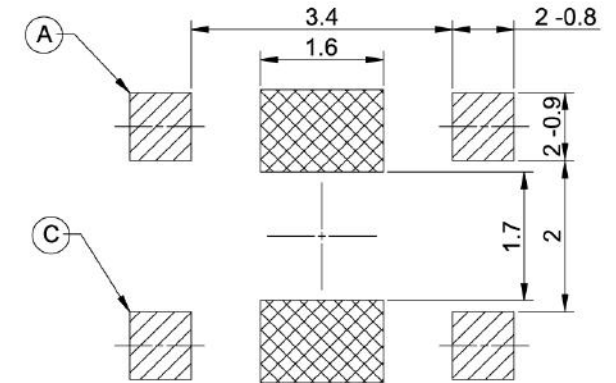

CIRCUIT DIAGRAM

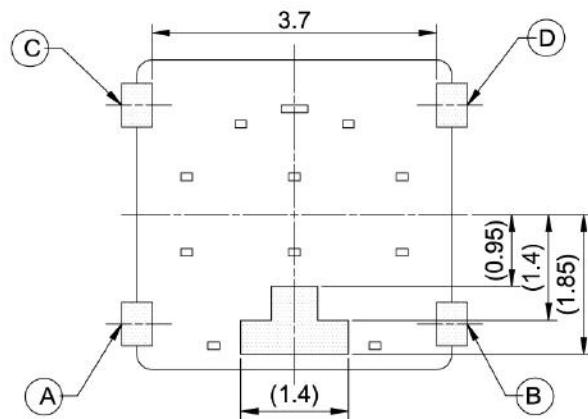
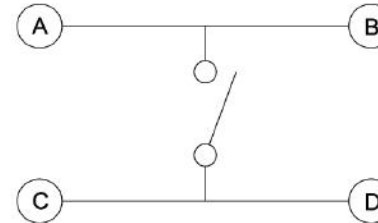

MODEL NAME

| NO | MODEL NAME | OPERATING FORCE | OPERATING LIFE |
|----|------------|-----------------|--------------------|
| 1 | TS-1197CP1 | 100gf ±50gf | 300000 CYCLES MIN. |
| 2 | TS-1197CP2 | 160gf ±50gf | |
| 3 | TS-1197CP3 | 250gf ±50gf | 100000 CYCLES MIN. |
| 4 | TS-1197CP4 | 350gf ±50gf | |

SPECIFICATION

1. RATING : DC 15V / 20mA
2. CONTACT RESISTANCE : MAX. 100mOhm
3. TRAVEL : 0.2 mm ±0.1mm
4. NON SPECIFIED DIMENSIONS TOLERANCE : ±0.2
5. WHEN DESIGNING A PORTION IS SHOWN AVOIDED.
(PCB PATTERN)

| GENERAL TOLERANCE (UNLESS SPECIFIED) | | SCALE | UNIT | TITLE | TS - 1197CP |
|---|-------------|---------------------------|-------------|-------------------------------------|------------------|
| ±0.2 | | 10 / 1 | METRIC | DOCUMENT NUMBER | R-T197P-AD-01A-A |
| | | THIRD ANGLE PROJECTION | SIZE A4 | Chi Fung Electronics (H.K) CO.,LTD. | |
| DRAWN BY | | CHECKED BY | APPROVED BY | | |
| REV | DESCRIPTION | Maclein | C.KIM | Jason | |