

1

2

3

4

REVISION

POSITION	DESCRIPTION	DATE

A

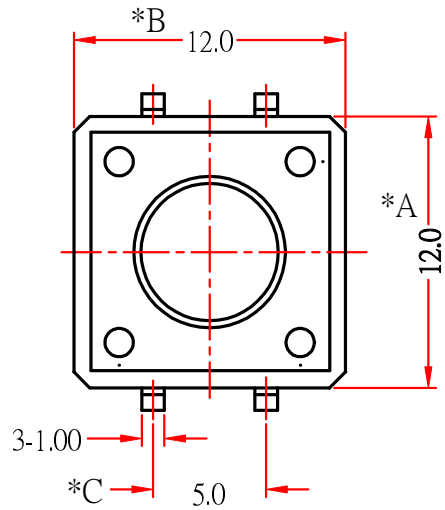

A

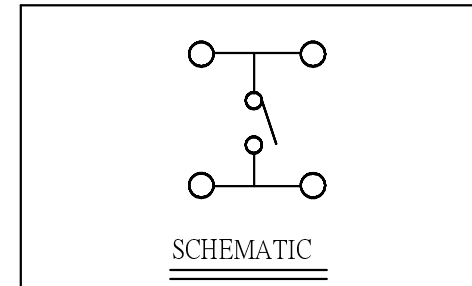

B

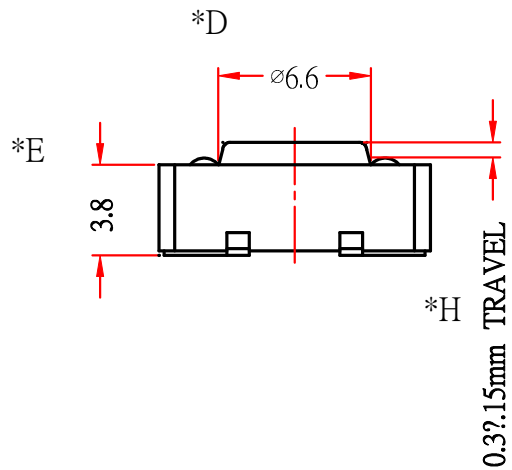

B

F=	L	130 gf
	S	160 gf
	H	250 gf
	E	350 gf

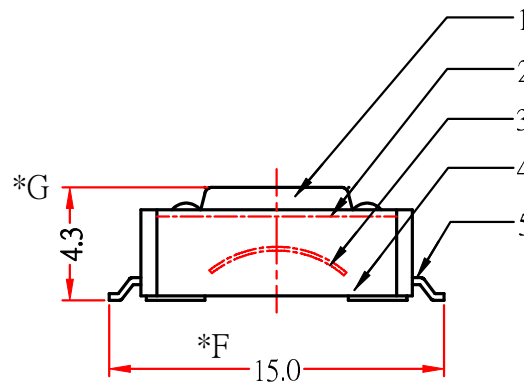

C

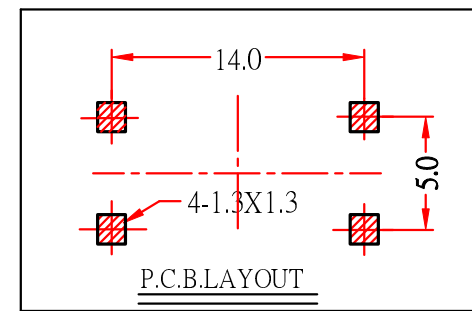

C

\* CRITICAL DIMENSION

D

CHI FUNG ELECTRONICS CO.,LTD.

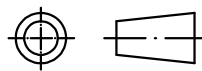

7				
6				
5	TERMINAL	BRASS	4	Ag COATING
4	CASE	PA6T	1	BLACK
3	CONTACT	C5210R-EH	1	Ag CLAD
2	COVER	SPN	1	Ni COATING
1	STEM	PA6T	1	BLACK
NO.	PART NAME	MATERIAL	QTY	FINISHING

D

SERIES : TACT SWITCH		DRAWING NO:	CF-ENL-TS4422-1
PART NAME: TS-12M-AFM-T		GENERAL TOLERANCE	
UNIT : M M	DWN.	WITHIN 0.XXmm?.15mm OVER 0.Xmm?.25mm	
SCALE : 3:1	CHK'D		
REV : A/0	APPD.		

1

2

3

4