

1

2

3

4

REVISION

POSITION	DESCRIPTION	DATE
△		

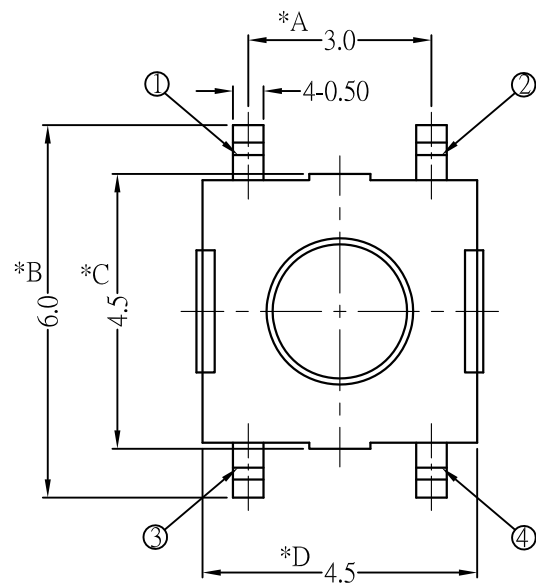

*E
0.2±0.1mm TRAVEL

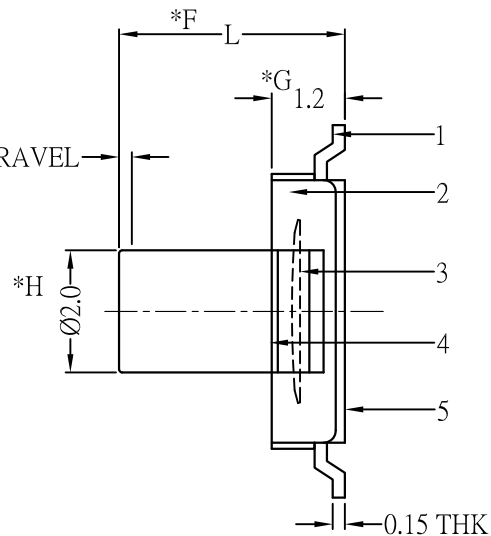

L= (height)	P	1.5 mm
	A	4.3 mm
	V	3.7 mm

F= (force)	2	130 gf
	4	180 gf
	7	250 gf

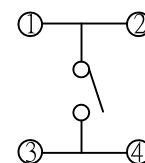

SCHEMATIC

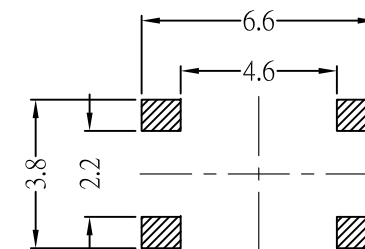

P.C.B.LAYOUT

* CRITICAL DIMENSION

CHI FUNG ELECTRONICS CO.,LTD.

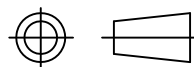

7				
6				
5	CASE	PA6T	1	BLACK
4	STEM	PA6T	1	BLACK
3	CONTACT	SUS	1	Ag CLAD
2	COVER	SUS	1	NATURAL
1	TERMINAL	BRASS STRIP	4	Ag PLATED
NO.	PART NAME	MATERIAL	QTY	FINISHING

SERIES : TACT SWITCH		DRAWING NO: CF-ENL-0TS9030	
PART NAME: TS-45M-LFD-01		GENERAL TOLERANCE	
UNIT : M M	DWN.	X.XXmm±0.15mm X.Xmm±0.25mm	
SCALE : 10:1	CHK'D		
REV : A/0	APPD.		

1

2

3

4