

Piezo Transducer Series

KLS3-PT-14*7.5 Without Circuit Piezo Transducer Buzzer Series

SPECIFICATIONS

Rated Voltage:	5Vp-p
Operating Voltage:	1 ... 20Vp-p
Max. Rated Current:	1mA
Min.S.P.L. (@ 10cm):	80dB
Resonant Frequency:	4.0 ± 0.5KHz
Capacitance at 1,000 Hz:	12000 ± 30% pF
Operating Temp:	-20°C~ +70 °C
Weight:	2g

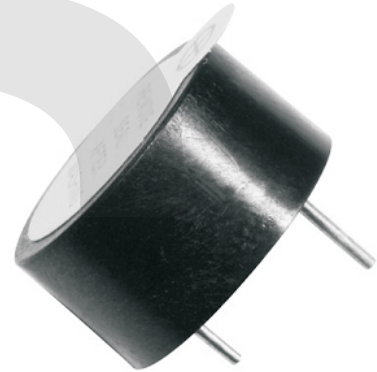

Dimensions (Unit:mm)

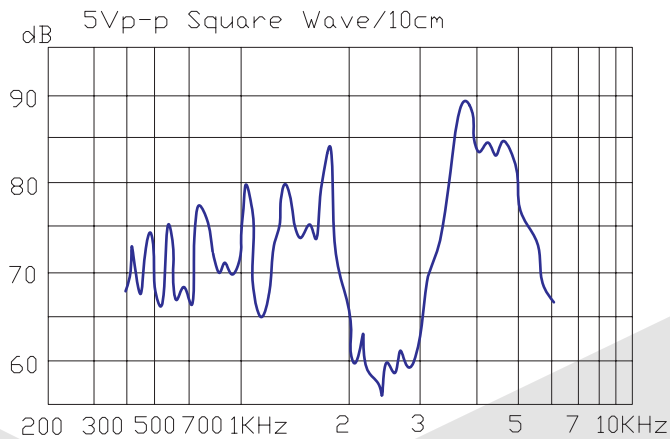
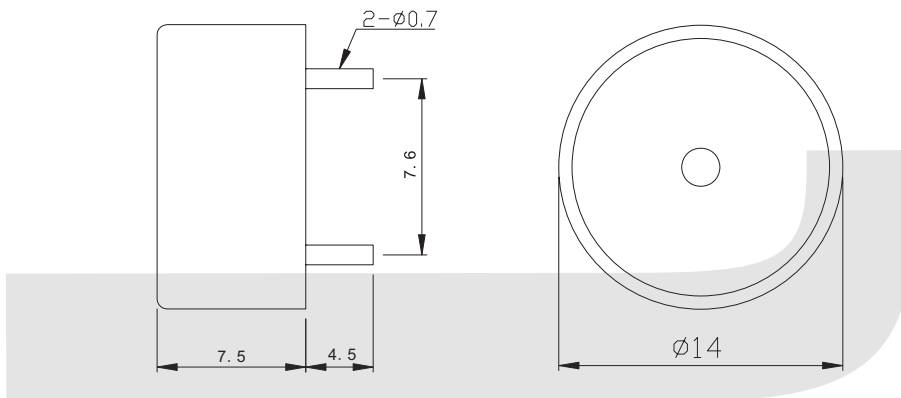

ORDER INFORMATION

Product No.: **KLS3 - PT - 14*7.5**

Part Number	Without Circuit Piezo Transducer Buzzer Series	Order Code
-------------	--	------------

