

1 2 3 4 5 6 7 8

A

B

C

D

E

F

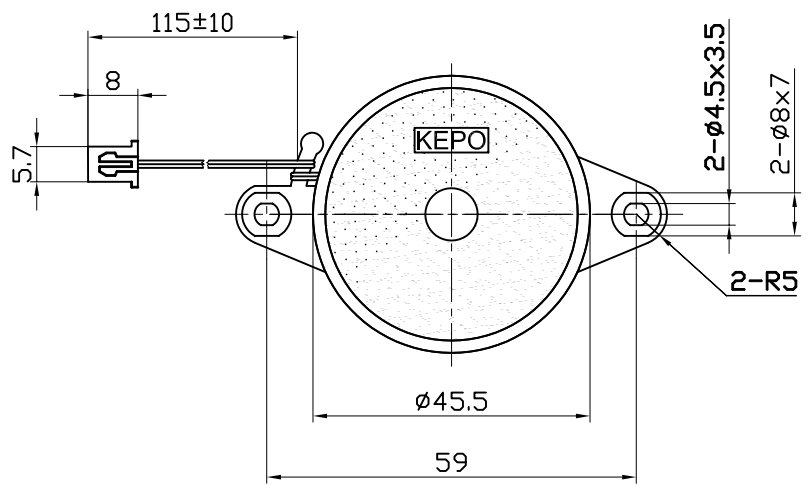
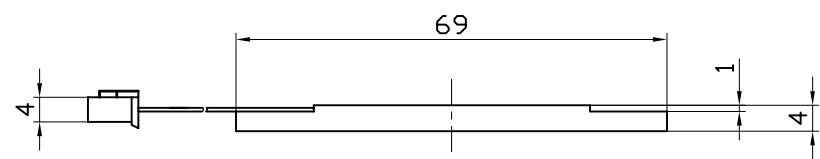

SPECIFICATION

1. Rated Voltage.....12Vp-p Square Wave
2. Max. Allowable Voltage.....30Vp-p Square Wave
3. Max. Rated Current :.....4mA at1.2 KHZ/12Vp-p Square Wave
4. Min. Sound Pressure Level...80dB at 1.2KHZ/12Vp-p Square Wave/30cm
5. Resonant Frequency 1.2±0.5 KHZ
6. Capacitance at 120Hz..... 66000pF±30%
7. Case Material.....ABS
8. Operating Temperature.....- 20~ + 60°C
9. Store Temperature.....- 30 ~ +70°C
10. Weight.....7g

				KEPO NINGBO KEEP IMPROVING ELECTRONIC CO.,LTD http://www.chinaacoustic.com	
No.	DESCRIPTION	APPROVED	DATE	Piezo transducer KPR-4610C	
<small>TOLERANCES UNLESS NOTED OTHERWISE X = .XX = .XXX = 90° FORMED ±2° ANGLES -1° FIRST ANGLE PROJECTION</small>		APPROVALS	DATE		
		DRAWN		UNIT	DWG NO.
		CHECKED		mm	KP3.840.330
		APPROVED	03.11.18	SCALE	SHEET
				NOT TO SCALE	VER 1.0

1 2 3 4 5 6 7 8