

宁波凯普电子有限公司

Ningbo Keep Improving Electronics Co.Ltd.

Tel:(+86)0574-88370330
Fax:(+86)0574-88370329

E-Mail: kepo@mail.nbptt.zj.cn
Http://www.chinaacoustic.com

制 品 规 格 书 Engineering Laboratory Specification

客户名称 Customer		凯普型号 Kepo Model	KPT-4413						
客户型号 Customer NO.		图号 DWG NO.	KP3.840.248						
概述 Scop.	此确认书仅使用于压电式声响器/蜂鸣器 This specification is only used for piezo transducer/buzzer								
编号 NO.	项 目 Items	规 格 Specifications							
1	额定电压 Rated Voltage	12Vp-p Square Wave							
2	工作电压 Operating Voltage	30Vp-p Square Wave							
3	额定电流 Max. Rated Current	5mA at 1.0KHz/12Vp-p Square Wave							
4	额定声压 Min. Sound Pressure Level	80dB at 1.0KHz/12Vp-p Square Wave/30cm							
5	音调 Tone Nature	/							
6	静电容量 Capacitance at 100Hz	85000pF ± 30%							
7	谐振频率 Resonant Frequency	1.0 ± 0.5KHz							
8	壳体材料/颜色 Shell Material/Color	ABS/Black							
9	工作温度 Operating Temperature	-20 ~ +60							
10	贮存温度 Store Temperature	-30 ~ +70							
11	重量 Weight	8g							
备注 Note:									
设计 Designed By	查核 Checked By	承认 Approved By	版本 VER.	1.1	日期 Date	01.10.08			

1

2

3

4

A

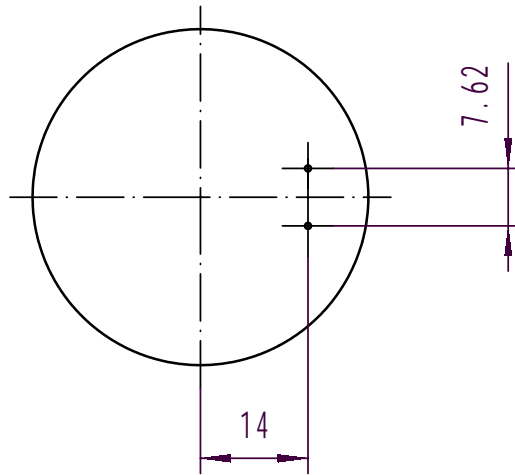

B

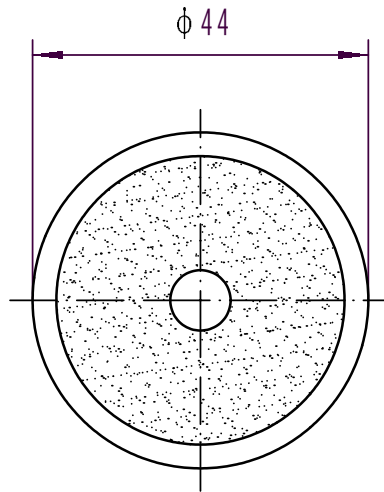

C

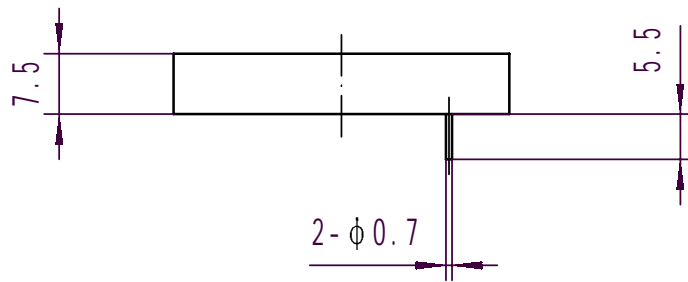

D

TOLERANCES UNLESS NOTED OTHERWISE

.X \pm
 .XX \pm
 .XXX \pm

90° FORMED +2°
 ANGLES -1°

FIRST ANGLE PROJECTION

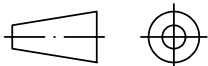

	SIGN	DATE	KEPO MODEL NO.	CUSTOMER			
DRAWN		02.06.20	KPT-4413	CUSTOMER NO.			
DESIGN				DWG NO.			
CHECK			KP3.840.248WX	REV	1.0	SHEET	
APPROVED				UNIT:		SCALE	
CONTRACT NO.			KEPO CO. LTD. TEL:(+86)574-88370330 FAX:(+86)574-88370329				
AGENCY APPROVAL							

1

2

3

4