

宁波凯普电子有限公司

Ningbo Keep Improving Electronics Co.Ltd.

Tel:(+86)0574-88370330
Fax:(+86)0574-88370329

E-Mail: kepo@mail.nbptt.zj.cn
Http://www.chinaacoustic.com

制 品 规 格 书 Engineering Laboratory Specification

客户名称 Customer		凯普型号 Kepo Model	KPT3-3000
客户型号 Customer NO.		图号 DWG NO.	KP3.840.222
概述 Scop.	此确认书仅使用于压电式声响器/蜂鸣器 This specification is only used for piezo transducer/buzzer		
编号 NO.	项 目 Items	规 格 Specifications	
1	额定电压 Rated Voltage	12VDC	
2	工作电压 Operating Voltage	3-24VDC	
3	额定电流 Max. Rated Current	12mA at 12VDC	
4	额定声压 Min. Sound Pressure Level	80dB at 12VDC/30cm	
5	音调 Tone Nature	Continuous	
6	静电容量 Capacitance at 100Hz	/	
7	谐振频率 Resonant Frequency	3.7 ± 0.5KHz	
8	壳体材料/颜色 Shell Material/Color	PBT/BLACK	
9	工作温度 Operating Temperature	-20 ~ +80	
10	贮存温度 Store Temperature	-30 ~ +100	
11	重量 Weight	4g	
备 注 Note:			
设计 Designed By	查核 Checked By	承认 Approved By	日期 Date 00.09.12

REVISIONS				APPLICATION	
REV	DESCRIPTION	DATE	APPROVED	NEXT ASSY	USED ON

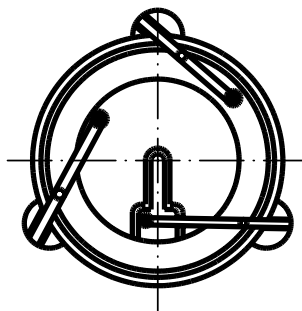
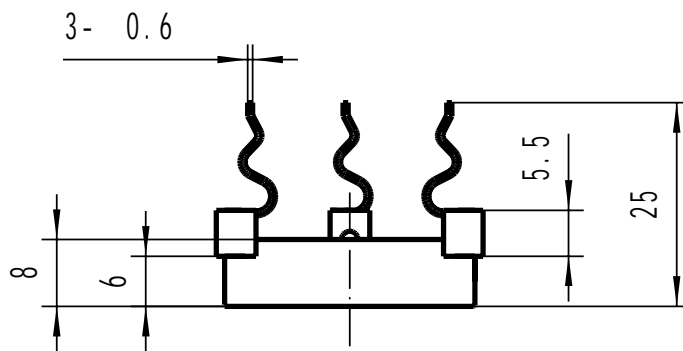
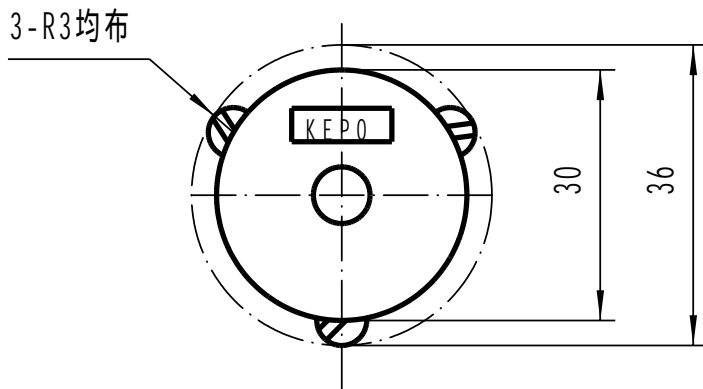

TOLERANCES UNLESS NOTED OTHERWISE .X ± .XX ± .XXX ± 90° FORMED +2° ANGLES -1°		SIGN	DATE	KEPO MODEL NO.	CUSTOMER	
	PREP.		00.09.12	KPT3-3000	CUSTOMER NO.	
	ENG.			DWG NO.	REV 1.0	SHEET
	QA.			KP3.840.222	UNIT: mm	SCALE
	PROJ.			CONTRACT NO.	KEPO CO.LTD. TEL:(+86)574-88370330 FAX:(+86)574-88370329	
FIRST ANGLE PROJECTION	AGENCY APPROVAL					