

+15kV ESD Protected、500kbps Data Rate RS-485

SSP3085

General Description

The SSP3085 is a half-duplex high speed transceiver for RS-485 and RS422 communication. IC contains one driver and one receiver.

The SSP3085 has a fail-safe circuit, ensure logical high level of receiver output when receiver input is open or short. It can achieve error-free data transmission of up to 500kbps. Each driver output and receiver input is protected against $\pm 15\text{kV}$ electrostatic discharge (HBM) (ESD) shocks.

The SSP3085 receiver has 1/8 unit load input impedance, allows up to 256 devices can be attached to the bus.

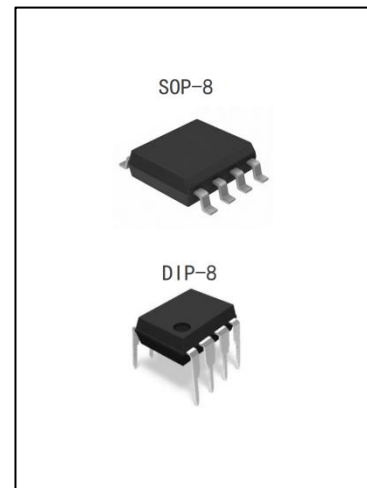

Features

- I/O pin ESD protection: +15kV HBM
Other pins have level 3 ESD protection: >+8kV HBM
- Fractional unit load allows up to 256 devices on the bus
- + 5V operating voltage
- Data transmission up to 500kbps
- Tri-state output
- SOP8 and DIP8 package

Applications

- RS-485/RS-422 transceiver
- Industrial process control
- Electric meter
- Industrial motor drive
- Automatic HVAC system

Order specification

Part No	Package	Manner of Packing	Devices per bag/reel
SSP3085	SOP8	Reel	4000

Block Diagram and Pin Arrangement Diagram

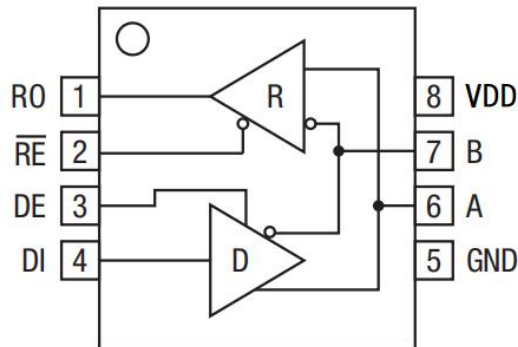

Pin Assignment

Pin No.	Pin Name	Description	I/O
1	RO	Receiver output: If $A-B \geq -0.05V$, RO will be high; If $A-B \leq -0.2V$, RO will be low; If A and B are open or shorted, RO will be high.	O
2	\overline{RE}	Receiver output enable: RO is enabled when \overline{RE} is low; RO is high impedance when \overline{RE} is high.	I
3	DE	Driver output enable: The driver outputs, A and B are enabled by bringing DE high. They are high impedance when DE is low.	I
4	DI	Driver input: A low on DI forces output A low and output B high. Similarly, a high on DI forces output A high and output B low.	I
5	GND	Ground	
6	A	Receiver input and driver output	I/O
7	B	Receiver input and driver output	I/O
8	VDD	Supply voltage	

Functional Description

The SSP3085 is a half-duplex high speed transceiver for RS-485 and RS422 communication. IC contains one driver and one receiver. The SSP3085 receiver has 1/8 unit load input impedance, allows up to 256 devices can be attached to the bus.

Receiver Truth Table

Input			Output
\overline{RE}	DE	A - B	RO
L	X	$\geq -0.05V$	H
L	X	$\leq -0.2V$	L
L	X	Open/shorted	H
H	H	X	Z
H	L	X	Z

Driver Truth Table

Input			Output	
\overline{RE}	DE	DI	B	A
X	H	H	L	H
X	H	L	H	L
L	L	X	Z	Z
H	L	X	Z	

Absolute Maximum Ratings

Unless specified otherwise, $T_{amb} = 25^{\circ}C$

Parameter	Symbol	Value	Unit
Supply Voltage	V_{DD}	-0.5~6	V
Input Voltage	V_{IN}	-0.5~6	V
Output Voltage	V_{OUT}	GND-0.3~ $V_{DD}+0.3$	V
A/B Input / Output Voltage	$V_{INA/B}/V_{OUTA/B}$	-7~12	V
Operating Temperature	T_{amb}	-40~85	$^{\circ}C$
Storage Temperature	T_{stg}	-65~150	$^{\circ}C$
Soldering Temperature(10s)	T_{sol}	300	$^{\circ}C$

DC Electrical Characteristics

Unless specified otherwise, $V_{CC}=5V\pm 5\%$, $T_{amb}= 25^{\circ}C$

Parameter	Symbol	Test Conditions	Min	Typ	Max	Unit	
Driver							
Differential driver output	V_{OD1}	No load			5	V	
Differential driver output	V_{OD2}	$R=50\Omega$ or $27\Omega^{(1)}$	2.0	3.0		V	
Change in magnitude of driver differential output voltage for complementary output states	ΔV_{OD}	$R=50\Omega$ or $27\Omega^{(1)}$			0.2	V	
Driver common-mode output voltage	V_{OC}	$R=50\Omega$ or $27\Omega^{(1)}$		$V_{DD}/2$	3	V	
Change in magnitude of driver common-mode output voltage for complementary output states	ΔV_{OC}	$R=50\Omega$ or $27\Omega^{(1)}$			0.2	V	
Input high voltage	V_{IH1}	DE、 \overline{RE} 、DI	2.0			V	
Input low voltage	V_{IL1}	DE、 \overline{RE} 、DI			0.8	V	
Input current	I_{IN1}	DE、 \overline{RE} 、DI			± 2	μA	
Input current (A, B)	I_{IN2}	DE=GND,	$V_{in}=5V$		40	90	μA
		$V_{CC}=5V$	$V_{in}=-0V$		60	100	μA
Receiver							
Differential threshold voltage	V_{TH}	$-7V \leq V_{CM} \leq 12V$	-250		-10	mV	
input hysteresis voltage	ΔV_{TH}			25		mV	
output high voltage	V_{OH}	$I_o=-4mA$	$V_{CC}-1.5$			V	
output low voltage	V_{OL}	$I_o=4mA$			0.4	V	
3-state(high impedance) output current at receiver	I_{OZR}	$0.4V \leq V_o \leq 2.4V$		± 1		μA	
input resistance	R_{IN}	$-7V \leq V_{CM} \leq 12V$	96			k Ω	
Receiver short-circuit current	I_{OSR}	$0V \leq V_{RO} \leq V_{DD}$		± 80		mA	
Supply Current	I_{CC}	No load, $\overline{RE}=DI$ =GND or V_{DD}	DE= V_{DD}		480	800	μA
			DE=GND		450	700	μA
ESD Protection (A/B)	ESD	Human Body Model	± 15			kV	

Transmission characteristics

Unless specified otherwise, $V_{CC}=5V\pm 5\%$, $T_{amb}=25^{\circ}C$

Parameter	Symbol	Test Conditions	Min.	Typ.	Max.	Unit
slew-rate-limited						
Driver Input to Output	t_{DPLH}	$R_{DIFF}=50\Omega$, $C_{L1}=C_{L2}=100pF^{(3)(6)}$	250		1000	ns
Driver Input to Output	t_{DPHL}	$R_{DIFF}=50\Omega$, $C_{L1}=C_{L2}=100pF^{(3)(6)}$	250		1000	ns
$ t_{DPLH}-t_{DPHL} $	t_{DSKEW}	$R_{DIFF}=50\Omega$, $C_{L1}=C_{L2}=100pF^{(3)(6)}$		-3	± 100	ns
Driver Rise or Fall Time	t_{DR}, t_{DF}	$R_{DIFF}=50\Omega$, $C_{L1}=C_{L2}=100pF^{(3)(6)}$	200		750	ns
Maximum Data Rate	f_{MAX}			500		kbps
Driver Enable to Output High	t_{DZH}	$C_L=100pF$, S2 closed ⁽⁴⁾⁽⁷⁾			2500	ns
Driver Enable to Output Low	t_{DZL}	$C_L=100pF$, S1 closed ⁽⁴⁾⁽⁷⁾			2500	ns
Driver Disable Time from Low	t_{DLZ}	$C_L=15pF$, S1 closed ⁽⁴⁾⁽⁷⁾			100	ns
Driver Disable Time from High	t_{DHZ}	$C_L=15pF$, S2 closed ⁽⁴⁾⁽⁷⁾			100	ns
Receiver Input to Output	t_{RPLH}	$ V_{ID} \geq 2.0V$ Rise or Fall Time \leq 15ns ⁽⁵⁾⁽⁸⁾			200	ns
Receiver Input to Output	t_{RPHL}				200	ns
$ t_{RPLH}-t_{RPHL} $	t_{RSKD}	$ V_{ID} \geq 2.0V$ Rise or Fall Time \leq 15ns ⁽⁵⁾⁽⁸⁾		3	± 30	ns
Receiver Enable to Output Low	t_{RZL}	$C_L=100pF$, S1 closed ⁽²⁾⁽⁹⁾		20	50	ns
Receiver Enable to Output High	t_{RZH}	$C_L=100pF$, S2 closed ⁽²⁾⁽⁹⁾		20	50	ns
Receiver Disable Time from Low	t_{RLZ}	$C_L=100pF$, S1 closed ⁽²⁾⁽⁹⁾		20	50	ns
Receiver Disable Time from High	t_{RHZ}	$C_L=100pF$, S2 closed ⁽²⁾⁽⁹⁾		20	50	ns

Note:

- (1) Test circuit is shown in Figure 1
- (2) Test circuit is shown in Figure 2
- (3) Test circuit is shown in Figure 3
- (4) Test circuit is shown in Figure 4

- (5) Test circuit is shown in Figure 5
- (6) Test circuit is shown in Figure 6
- (7) Test circuit is shown in Figure 7
- (8) Test circuit is shown in Figure 8
- (9) Test circuit is shown in Figure 9

Test Circuit

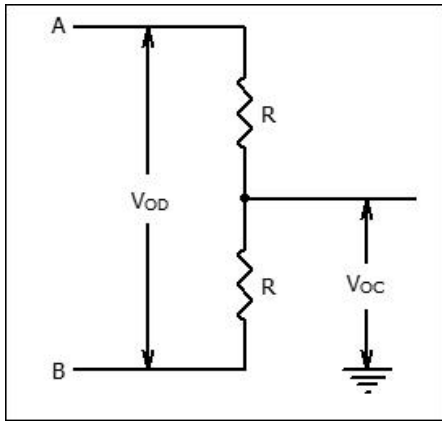

Figure 1 Driver DC Test Load

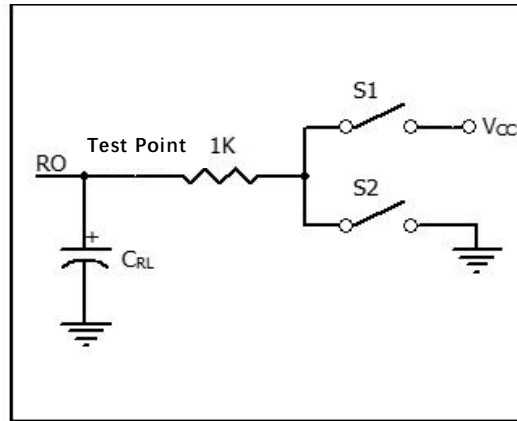

Figure 2 Receiver Enable/Invalid Timing Test Circuit

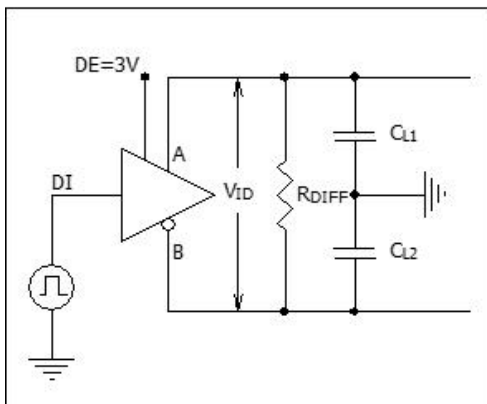

Figure 3 Driver Timing Test Circuit

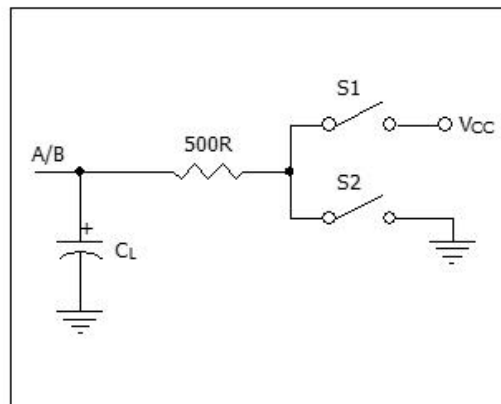

Figure 4 Driver Enable/Invalid Timing Test Circuit

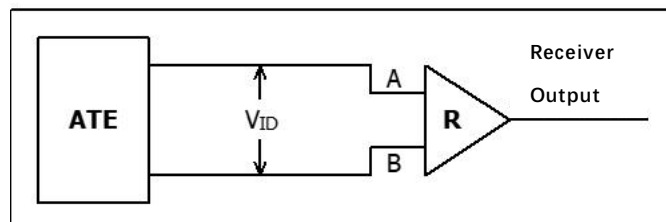

Figure 5 Receiver Propagation Delay Test Circuit

Switching Waveforms

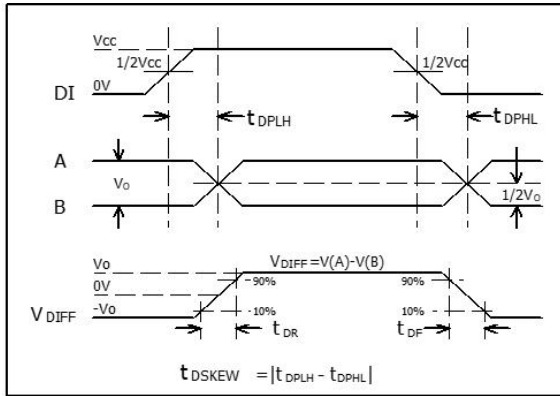

Figure 6 Driver Propagation Delays

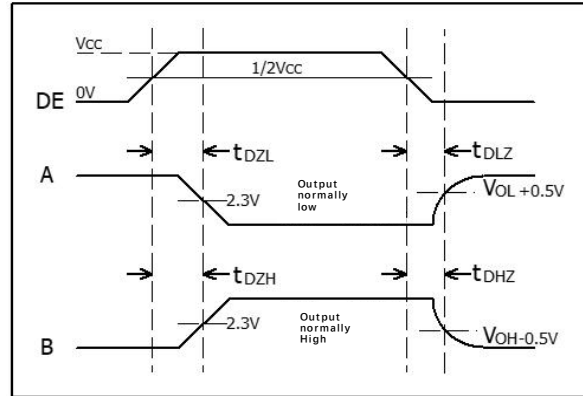

Figure 7 Driver Enable and Disable Times

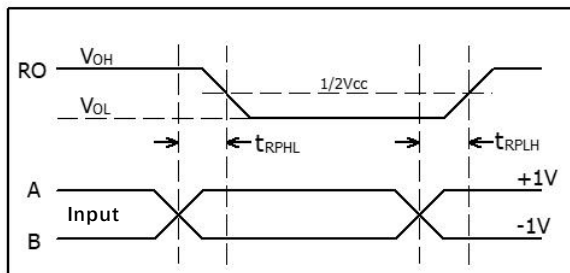

Figure 8 Receiver Propagation Delays

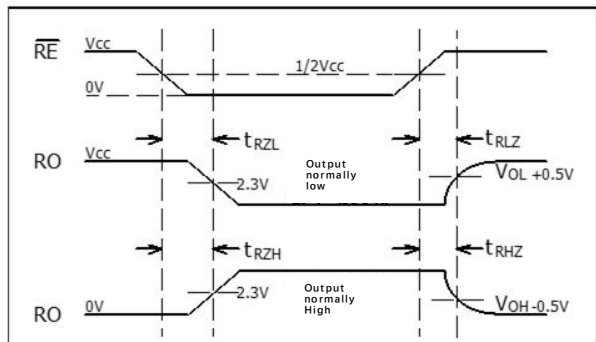

Figure 9 Receiver Enable and Disable Times

Application Circuits

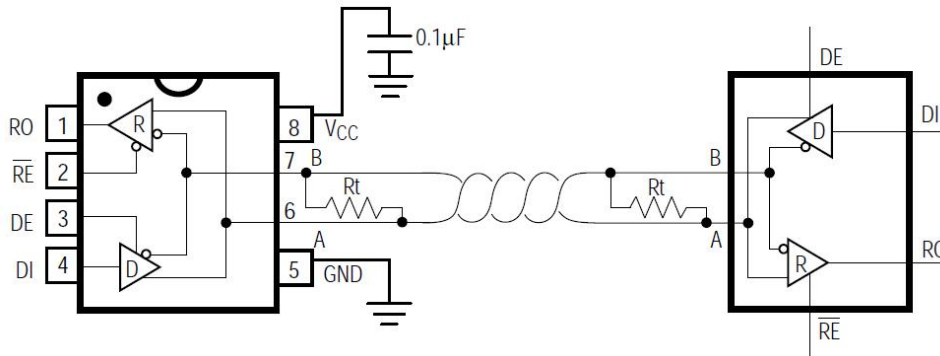

Figure 10 Typical Application Chart

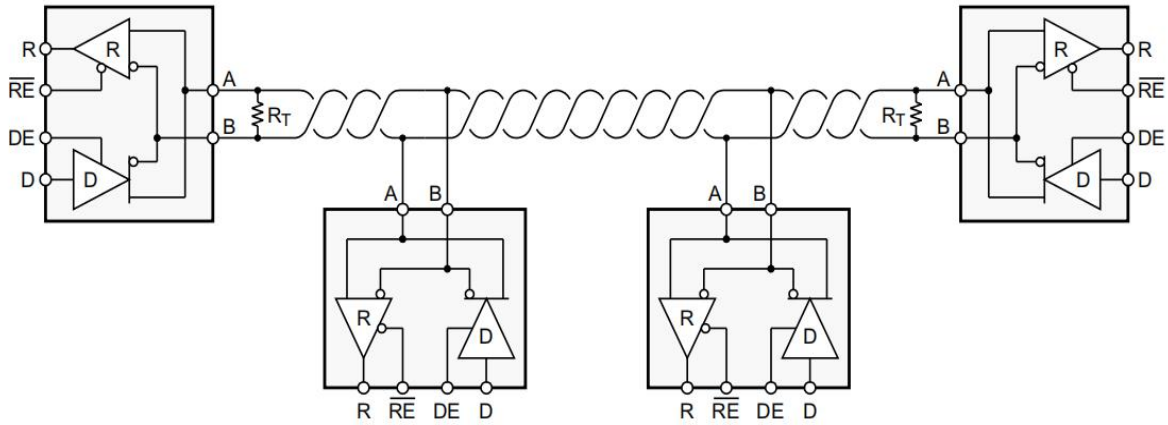
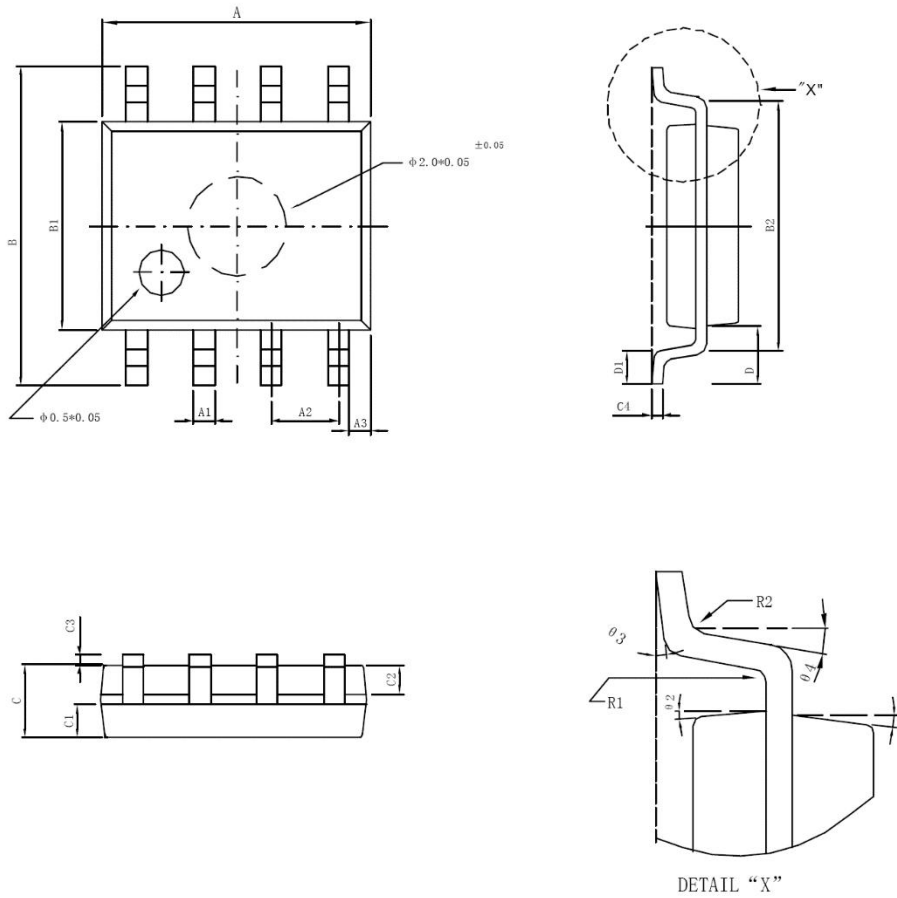
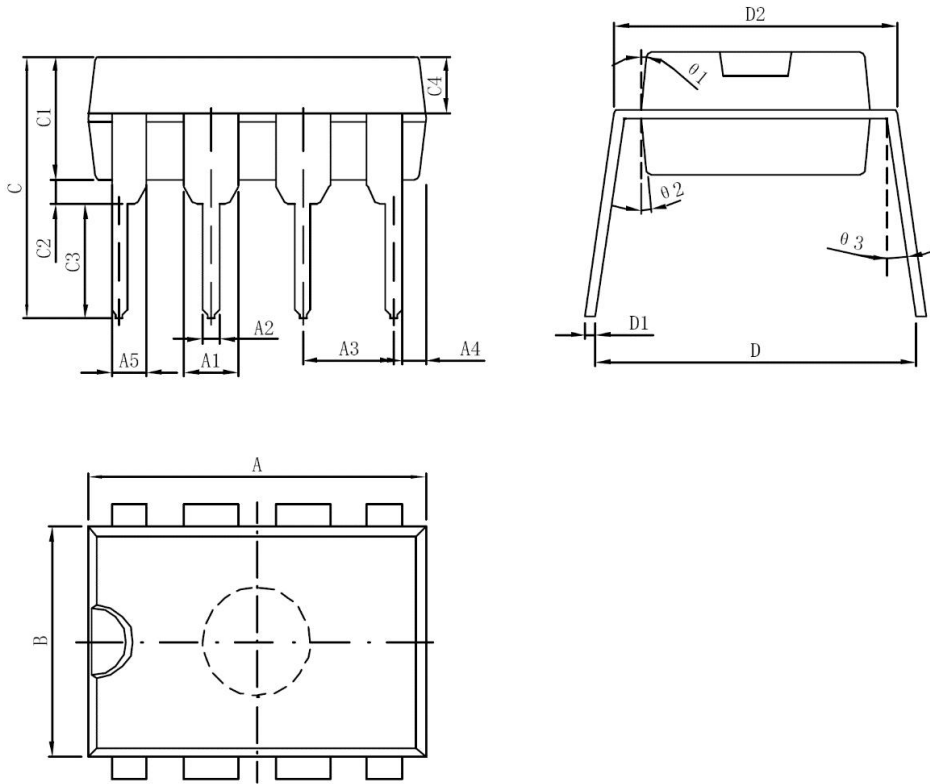

Figure 11 Typical Half-duplex 485 Network

Package Information (SOP8)



Symbol	Min. (mm)	Max.(mm)	Symbol	Min. (mm)	Max. (mm)
A	4.95	5.15	C3	0.10	0.20
A1	0.37	0.47	C4	0.20TYP	
A2	1.27TYP		D	1.05TYP	
A3	0.41TYP		D1	0.50TYP	
B	5.80	6.20	R1	0.07TYP	
B1	3.80	4.00	R2	0.07TYP	
B2	5.0TYP		θ1	17°TYP	
C	1.30	1.50	θ2	13°TYP	
C1	0.55	0.65	θ3	4°TYP	
C2	0.55	0.65	θ4	12°TYP	

Package Information (DIP8)

Symbol	Min. (mm)	Max. (mm)	Symbol	Min. (mm)	Max. (mm)
A	9.30	9.50	C2	0.50	
A1	1.524		C3	3.3	
A2	0.39	0.53	C4	1.57TYP	
A3	2.54		D	8.20	8.80
A4	0.66TYP		D1	0.20	0.35
A5	0.99TYP		D2	7.62	7.87
B	6.3	6.5	theta 1	8°TYP	
C	7.20		theta 2	8°TYP	
C1	3.30	3.50	theta 3	5°TYP	

Special Instructions

The company reserves the right of final interpretation of this specification.

Version Change Description

Version: V1.3

Author: Yangyang

Time: 2021.8.12

Modify the record:

1. Re-typesetting the manual and checking some data
-

Statement

The information in the usage specification is correct at the time of publication, Shanghai Siproin Microelectronics Co. has the right to change and interpret the specification, and reserves the right to modify the product without prior notice. Users can obtain the latest version information from our official website or other effective channels before confirmation, and verify whether the relevant information is complete and up to date.

With any semiconductor product, there is a certain possibility of failure or failure under certain conditions. The buyer is responsible for complying with safety standards and taking safety measures when using the product for system design and complete machine manufacturing. The product is not authorized to be used as a critical component in life-saving or life-sustaining products or systems, in order to avoid potential failure risks that may cause personal injury or property loss.