

NOTES:
 DATE CODE 0202 (YWWD)
 Y: 0 YEAR(2010)
 WW:20 WEEK(01~52)
 D: 2 DAY(01~07)

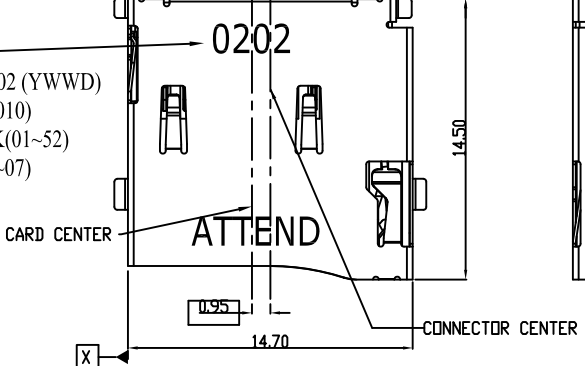

Material:
 Plastic Body : LCP+35%GF, Color Black.
 Slider : LCP+35%GF, Color Black.
 Contact :Phosphor Bronze Alloy (C5210R-EH)
 Contacts Plating:Contact area: Gold 10 micro inches (Min.)
 Solder area: Gold flash
 All under-plated Ductile Nickel 50 micro inches (Min.)
 Shell :SUS304R-3/4H
 Plating:
 Contact area: Gold flash
 Solder area: Gold flash
 All under-plated Ductile Nickel 12 micro inches (Min.)

Spring : Piano Wire
 Drag Link : SUS304

PRODUCT NUMBER:
 112J-I X A R-R01
 1 2 3

- Type
T:Top Mount
- Contact Plating
A:Gold Flash
D:10u" Gold Plating
- Stand Off
A:0mm

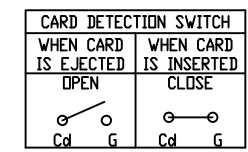

PART NAME	Q'TY	MATERIAL
BODY	1	LCP+35%GF
SLIDER	1	LCP+35%GF
CONTACT	1	C5210R-EH
SHELL	1	SUS304R-3/4H
DRAW LINK	1	SUS304
SPRING	1	PIAND WIRE

PIN NUMBER	PIN ASSIGNMENT	PIN NUMBER	PIN ASSIGNMENT
1	DAT2	6	VSS
2	CD/DAT3	7	DAT0
3	CMD	8	DAT1
4	VDD	Cd	CARD DETECTION
5	CLK	G	GROUND

UNLESS OTHERWISE SPECIFIED TOLERANCE		
ANGLES	ANG.	±5°
LINEAR	0.	±0.3
	0.0	±0.25
	0.00	±0.20
SCALE	AS SHOWN	UNIT: mm
DRAWN	Willis	2014/01/09
CHECKED	Angel	2014/01/09
APPROVED	Ken	2014/01/09



- Revise:
- Revise:
- Revise:

REV.	DESCRIPTION	DATE	REV.	DESCRIPTION	DATE	SIZE	REV.	FILE NAME
1						A4	1.0	112J-TXAR-R01_B_2

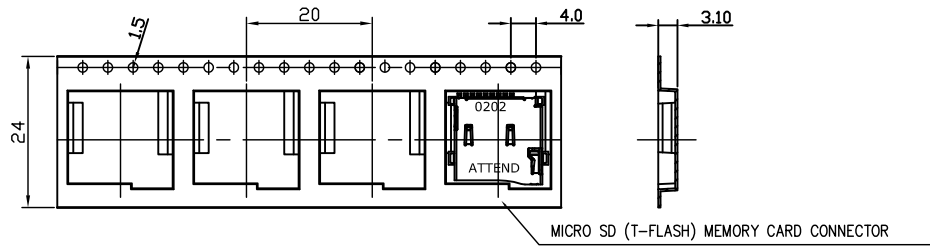

NOTES:

1. PACKING STYLE 1,000 PCS/REEL
2 REEL/INNER CARTON
10,000 PCS/OUTER CARTON
2. MATERIAL CARRIER TAPE:PS BLACK
COVER TAPE:PET FILM
REEL:PLASTIC
3. PEEL STRENGTH OF COVER TAPE:20-80g(PEEL SPEED 300mm/MINUTE).

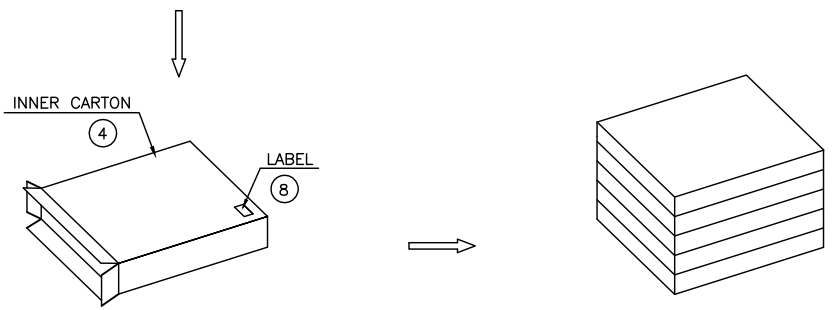
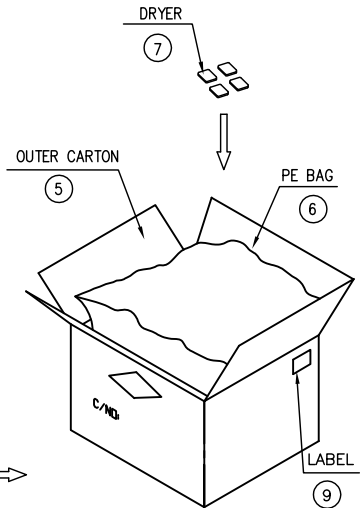
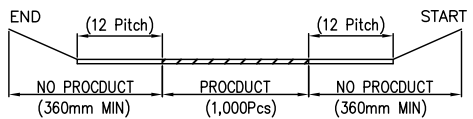
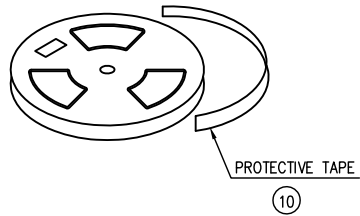
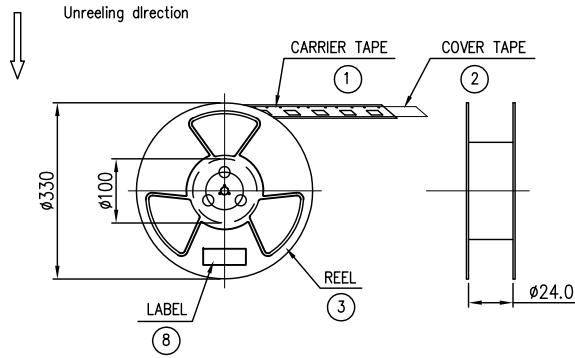

10	PROTECTIVE TAPE	1	PCS	
9	LABEL	1	PCS	
8	LABEL	15	PCS	
7	DRYER	4	BAG	
6	PE BAG	1	PCS	L850*W750mm
5	OUTER CARTON	1	PCS	
4	INNER CARTON	5	PCS	
3	REEL	10	SET	φ330*100mm,W=24mm
2	COVER TAPE	1,000	10	PCS W=21.5mm,20.8M
1	CARRIER TAPE			W=24mm,T=0.35mm,20.8M/REEL
NO PACKING NAME		PCS/T	T/BOX	UNIT
		PACKING QTY		NOTE

UNLESS OTHERWISE SPECIFIED TOLERANCE		
ANGLES	ANG.	±5°
LINEAR	0.	±0.3
	0.0	±0.25
	0.00	±0.20
SCALE	AS SHOWN	UNIT: mm
DRAWN	Willis	2014/01/09
CHECKED	Angel	2014/01/09
APPROVED	Ken	2014/01/09
SIZE	A4	REV. 1.0

www.attend.com.tw

DRAWN NAME: Micro SD Socket Push-Push Type

PRODUCT NO. 112J-TXAR-R01

FILE NAME 112J-TXAR-R01_D_1

REV.	DESCRIPTION	DATE	REV.	DESCRIPTION	DATE
1			4		
2			5		
3			6		
4			7		

- Revise:
- Revise:
- Revise: