

Panel Cut-Out

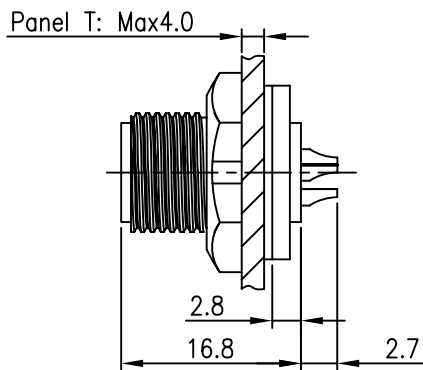

Table 2 (Hole Arrangement, Mating Face)

2Pos	3Pos	4Pos	4Pos
110 v 5 A	110 v 5 A	110 v 5 A	50 v 2 A

5Pos	6Pos	(2+4)Pos	7Pos	8Pos
50 v 2 A	50 v 2 A	50 v 5+2 A	50 v 2 A	50 v 2 A

UNIT:mm	
TOLERANCE	
.X	±0.25
.XX	±0.15
.XXX	±0.05
ANGLES	±1°

Description	
Mini Series Screw Type, Front Mount, Pin Solder	
SCALE: N/A	SHEET 1 OF 1
REV. D1	SIZE A4
* :Inspection Item	

CHOGORI

REV.	ECN NO.	DESCRIPTION	SIGN	DATE
D1	N/A	INITIAL DRAWING	Wu.Xi	2013/04/10

Table 1

Position No.	Connector Part No.	2 Housing Part No.	1 Contact		
			Contact Part No.	Q'ty	Contact Description
2	21002515-01	105-00031-00	301-00052-02	2	MZBPφ1.0
3	21003515-01	105-00036-00	301-00052-02	3	MZBPφ1.0
4	21004515-01	105-00042-00	301-00052-02	4	MZBPφ1.0
4	21004515-02	105-00040-00	301-00067-02	4	MZPφ0.8
5	21005515-01	105-00048-00	301-00067-02	5	MZPφ0.8
6	21006515-01	105-00052-00	301-00067-02	6	MZPφ0.8
2+4	21204515-01	105-00027-00	301-00052-02	2	MZBPφ1.0
			301-00067-02	4	MZPφ0.8
7	21007515-01	105-00056-00	301-00067-02	7	MZPφ0.8
8	21008515-01	105-00061-00	301-00067-02	8	MZPφ0.8

Specification:

- 1.Operation temperature:-45°C~105°C.
- 2.Insulation resistance:100MΩ at DC500V.
- 3.Contact resistance:<10mΩ.
- 4.Waterproof:IP67.
- 5.RoHS compliant.
- 6.Mating Waterproof Cap P/N:806-00028-00.
- 7.Mating Connector P/N:21XXX211-XX or 21XXX213-XX-001 or 21XXX214-XX-001.

Material List				
No.	Material No.	Q'ty	Material Description	Remark
1	See above table 1		Contact	
2	See above table 1	1	Mini-XX Pos Housing	
3	503-00010-00	1	Mini Gasket	
4	112-00012-00	1	Mini Panel Nut	

PART NO	21XXX515-01(02)	DRAWN BY	Wu.Xi	DATE	2013-04-10
DWG NO		CHECKED BY		DATE	
CUSTOMER		APPROVED BY		DATE	

THIS INFORMATION IS CONFIDENTIAL AND IS DISCLOSED TO YOU ON CONDITION THAT NO FURTHER DISCLOSURE IS MADE BY YOU TO OTHER THAN CHOGORI PERSONNEL WITHOUT AUTHORIZATION FROM CHOGORI CORP.