

MD1S THRU MD7S

MINIATURE GLASS PASSIVATED SINGLE PHASE SURFACE MOUNT BRIDGE RECTIFIER

Reverse Voltage – 50 to 1000 Volts

Forward Current – 0.5 Ampere

Features

- Surge overload rating: 30 amperes peak
- Ideal for printed circuit board
- Low leakage
- Reliable low cost construction utilizing molded
- Plastic package has Underwriters Laboratory Flammability Classification 94V-O

Mechanical Data

- **Case:** MD-S, molded plastic.
- **Terminals:** Leads solderable per MIL-STD-202, method 208.
- **Mounting position:** Any.
- **Weight:** 0.008 ounce, 0.22 grams.

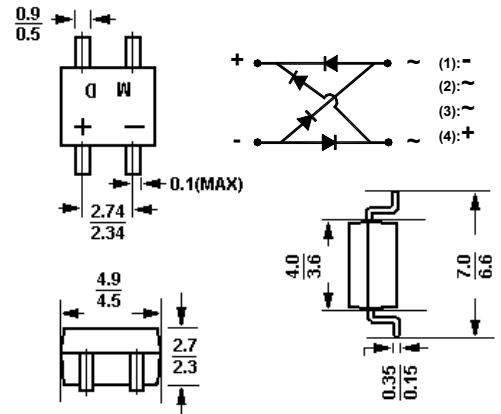

Dimensions in mm

Absolute Maximum Ratings and Characteristics

Ratings at 25°C ambient temperature unless otherwise specified. Single phase, half wave, 60 Hz, resistive or inductive load. For capacitive load, derate current by 20%.

	Symbols	MD1S	MD2S	MD3S	MD4S	MD5S	MD6S	MD7S	Units
Maximum recurrent peak reverse voltage	V_{RRM}	50	100	200	400	600	800	1000	V
Maximum RMS voltage	V_{RMS}	35	70	140	280	420	560	700	V
Maximum DC blocking voltage	V_{DC}	50	100	200	400	600	800	1000	V
Maximum average forward rectified current See Fig .1 On glass epoxy P.C.B.(Note 2) On aluminum substrate(Note 3)	$I_{(AV)}$				0.5 0.8				A
Peak forward surge current 8.3ms single half sine-wave superimposed on rated load (JEDEC method)	I_{FSM}				30				A
Maximum forward voltage at 0.4A DC	V_F				1.0				V
Maximum reverse current at rated DC blocking voltage @ $T_A = 25^\circ C$ @ $T_A = 125^\circ C$	I_R				5.0 500				μA
Typical junction capacitance (Note 1)	C_J				13				pF
Typical thermal resistance (Note 3)	$R_{\theta JA}$				70				$^\circ C/W$
Typical thermal resistance (Note 2)	$R_{\theta JL}$				20				$^\circ C/W$
Operating and storage temperature range	T_J, T_S				-55 to +150				$^\circ C$

Notes: (1) Measured at 1 MHz and applied $V_r = 4$ volts.

(2) On glass epoxy P.C.B. mounted on 0.05 x 0.05" (1.3 x 1.3 mm) pads.

(3) On aluminum substrate P.C.B. with an area of 0.8 x 0.8" (20 x 20mm) mounted on 0.05 x 0.05" (1.3 x 1.3mm) solder pad.

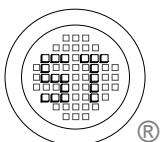

SEMTECH ELECTRONICS LTD.

(Subsidiary of Semtech International Holdings Limited, a company listed on the Hong Kong Stock Exchange, Stock Code: 724)

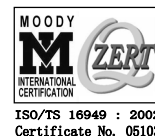

MD1S THRU MD7S

Derating curve for output rectified current

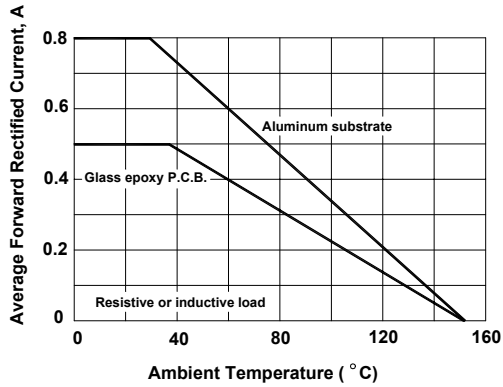

Typical Forward Voltage Characteristics per element

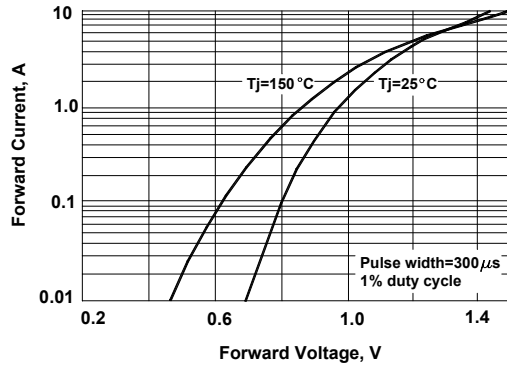

Max Non-repetitive Peak Forward Surge Current per leg

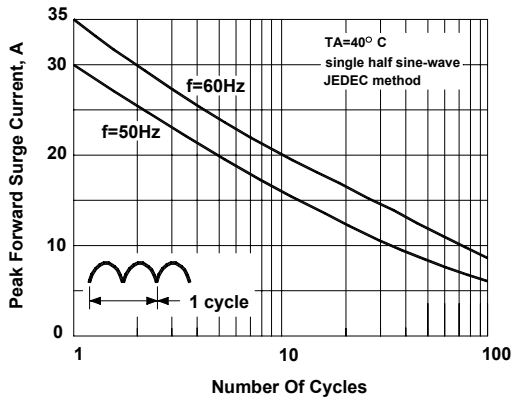

Typical Reverse Leakage Characteristics per leg

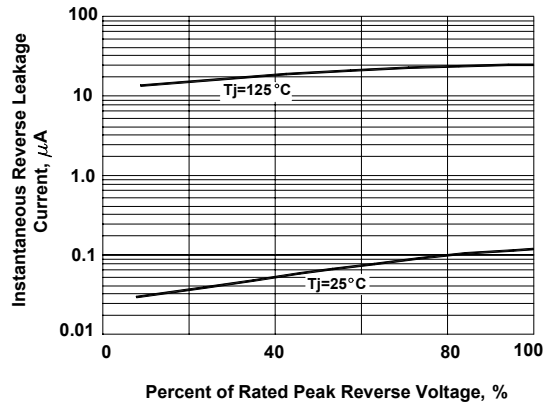

Typical Junction Capacitance Per Leg

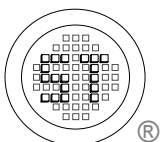
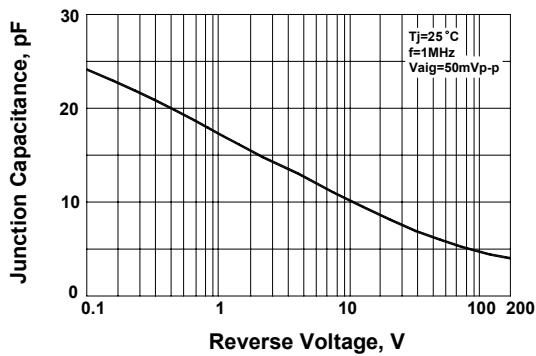

SEMTECH ELECTRONICS LTD.
(Subsidiary of Semtech International Holdings Limited, a company listed on the Hong Kong Stock Exchange, Stock Code: 724)

