

# MB05S thru MB10S



## 0.5 A Single-Phase Glass Passivated Bridge Rectifiers

Rectifier Reverse Voltage 50 to 1000V



MINI-DIP

### Features

- This series is UL listed under the Recognized Component Index, file number E142814
- Ideal for surface mount application
- The plastic material used carries Underwriters Laboratory flammability recognition 94V-0
- Surge overload ratings to 30 amperes
- High temperature soldering guaranteed 265°C /10 seconds at 5 lbs (2.3kg) tension

### Mechanical Data

Case: Molded plastic  
 Terminals: Plated leads solderable per MIL-STD-202, Method 208  
 Polarity: Marked on body  
 Mounting Position: Any  
 Weight: 0.0044 ounce, 0.125 grams (approx)

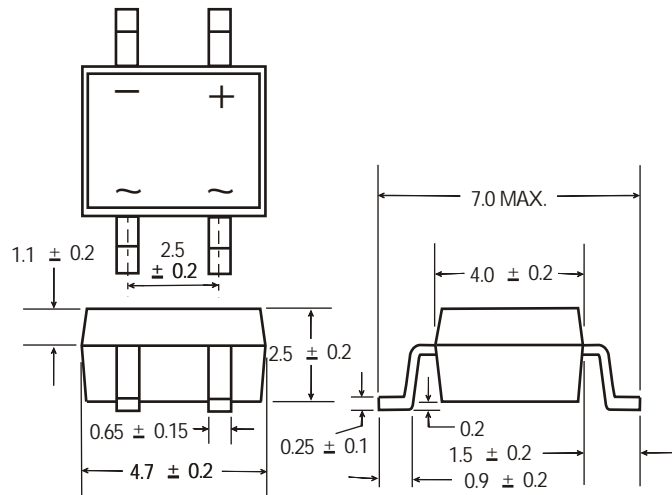

Dimensions in millimeters(1mm =0.0394")

### Maximum Ratings & Thermal Characteristics

Rating at 25°C ambient temperature unless otherwise specified, Resistive or Inductive load, 60 Hz.  
 For Capacitive load derate current by 20%.

Parameter	Symbol	MB05S	MB1S	MB2S	MB4S	MB6S	MB8S	MB10S	unit
Maximum repetitive peak reverse voltage	VRRM	50	100	200	400	600	800	1000	V
Maximum RMS bridge input voltage	VRMS	35	70	140	280	420	560	700	V
Maximum DC blocking voltage	VDC	50	100	200	400	600	800	1000	V
Maximum average forward rectified output current at TA=40°C	IF(AV)	0.5							A
Peak forward surge current single sine-wave superimposed on rated load (JEDEC Method)	IFSM	30							A
Rating for fusing ( t<8.3ms)	I <sup>2</sup> t	10							A <sup>2</sup> sec
Typical thermal resistance per element (1)	ReJA	110							°C/W
Typical junction capacitance per element (2)	Cj	25.0							pF
Operating junction and storage temperature range	TJ, TSTG	-55 to + 150							°C

### Electrical Characteristics

Rating at 25°C ambient temperature unless otherwise specified. Resistive or Inductive load, 60Hz.  
 For Capacitive load derate by 20 %.

Parameter	Symbol	MB05S	MB1S	MB2S	MB4S	MB6S	MB8S	MB10S	Unit
Maximum instantaneous forward voltage drop per leg at 0.5A	VF	1.1							V
Maximum DC reverse current at rated TA =25°C DC blocking voltage per element TA =125°C	IR	10 500							μA

**Notes:** (1)Thermal resistance from Junction to Ambient on P.C.board mounting.  
 (2)Measured at 2.0MHz and applied reverse voltage of 4.0 volts.



# Rating and Characteristic Curves ( $T_A=25^{\circ}\text{C}$ Unless otherwise noted ) MB05S thru MB10S

**Fig. 1 Derating Curve for Output Rectified Current**

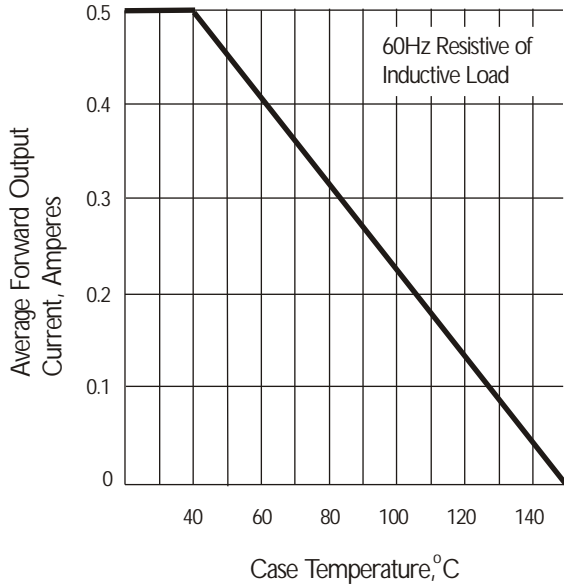

**Fig. 2 Maximum Non-repetitive Peak Forward Surge Current**

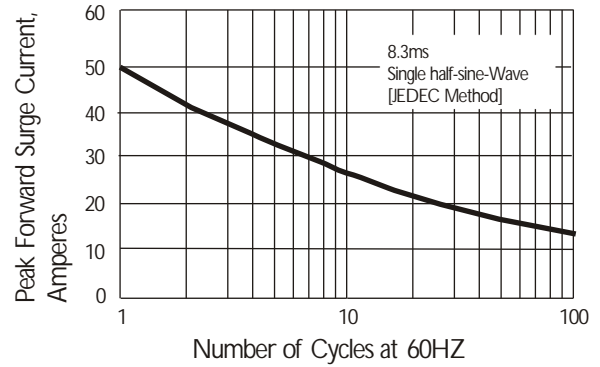

**Fig. 3 Typical Instantaneous Forward Characteristics**

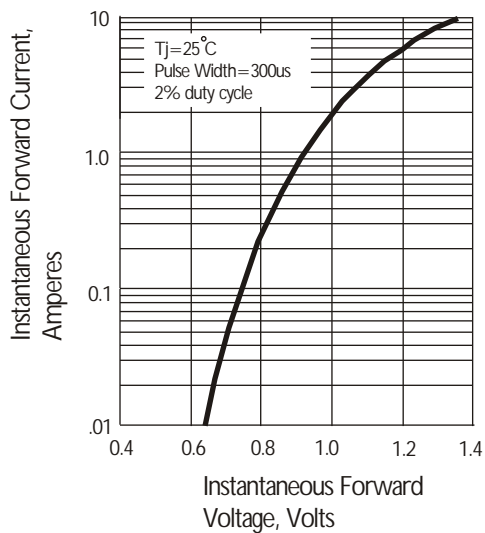

**Fig. 4 Typical Revers Characteristics**

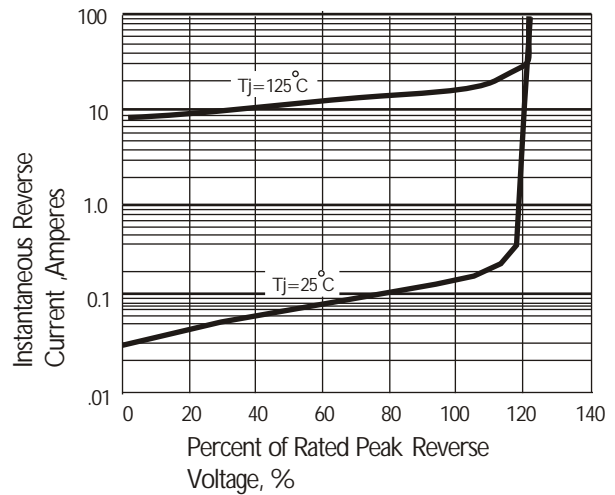

**Fig. 5 Typical Junction Capacitance**

