

Spark Gap (SPG) Data Sheet

Features

- Approximately zero leaking current before clamping voltage
- Less decay at on/off state.
- High capability to withstand repeated lightning strikes.
- Low electrode capacitance($\leq 0.8\text{pF}$) and high isolation($\geq 100\text{M}\Omega$).
- RoHS compliant.
- Bilateral symmetrical.
- Temperature, humidity and lightness insensitive.
- Operating temperature: $-40^{\circ}\text{C} \sim +85^{\circ}\text{C}$
- Storage temperature: $-40^{\circ}\text{C} \sim +125^{\circ}\text{C}$
- Meets MSL level 1, per J-STD-020
- Safety certification: UL: E244458



Applications

- Power Supplies
- Motor sparks eliminating
- Relay switching spark absorbing
- Data line pulse guarding
- Electronic devices requiring UL497A and UL497B compliant
- Telephone/Fax/Modem
- High frequency signal transmitters/receivers
- Satellite antenna
- Radio amplifiers
- Alarm systems
- Cathode ray tubes in Monitors/TVs

Dimensions

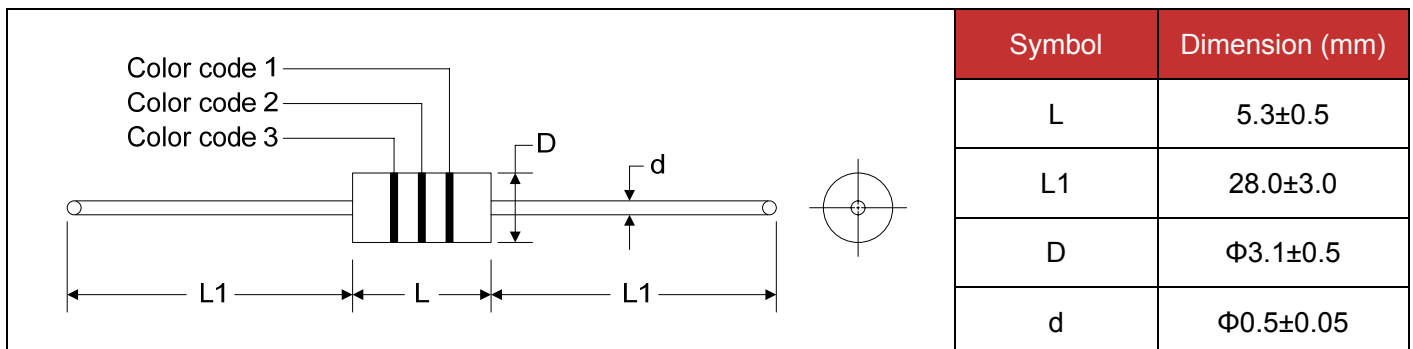

Electrical Characteristics

Part Number ①	Type ②	DC Spark-over Voltage	Minimum Insulation Resistance		Maximum Capacitance (1KHz-6V _{MAX})	Surge current capacity (8/20μs)	Surge Life Test
		Vs(V)	Test Voltage(V)	IR _{OHM} (MΩ)	C(pf)		8/20μs, 100A
BK1XX05002	P	1000	500	100	0.8	3000A	250 times
BK1XX07502	P	1500	500	100	0.8	3000A	250 times
BK1XX09002	P	1800	500	100	0.8	3000A	250 times
BK1XX10002	P	2000	500	100	0.8	3000A	250 times
BK1XX12002	P	2400	500	100	0.8	3000A	250 times
BK1XX13502	P	2700	500	100	0.8	3000A	250 times
BK1XX15002	P	3000	500	100	0.8	3000A	250 times
BK1XX18002	P	3600	500	100	0.8	3000A	250 times
BK1XX20002	P	4000	500	100	0.8	3000A	250 times
BK1XX22502	P	4500	500	100	0.8	3000A	250 times
BK1XX25002	P	5000	500	100	0.8	3000A	250 times

Note: ① Vs±XX%

② Specific code by request.

Color Code

Part Number	Type	Color Code 1	Color Code 2	Color Code 3
BK1XX05002	P	Brown	Black	Red
BK1XX07502	P	Brown	Green	Red
BK1XX09002	P	Brown	Gray	Red
BK1XX10002	P	Red	Black	Red
BK1XX12002	P	Red	Yellow	Red
BK1XX13502	P	Red	Purple	Red
BK1XX15002	P	Orange	Black	Red
BK1XX18002	P	Orange	Blue	Red
BK1XX20002	P	Yellow	Black	Red
BK1XX22502	P	Yellow	Green	Red
BK1XX25002	P	Green	Black	Red

Test Methods and Results

Items	Test Method	Standard
DC Spark-over Voltage	Measure starting discharge voltage (Vs) by gradually increasing applied DC voltage. Test current is 0.5mA max. And the DC voltage ascends up within 500V/second.	Meet specified value.
Insulation Resistance	Measure the insulation resistance across the terminal at regular voltage. But the test voltage doesn't over the DC spark-over voltage.	
Capacitance	Measure the electrostatic capacitance by applying a voltage of less than 6V (at 1KHz) between terminals.	
Static Life	10KV with 1500pf condenser is discharged through 0Ω resistor. 200 times at an interval of 10sec.	$ \Delta Vs/Vs \leq 30\%$ Characteristics of other items must meet the specified value.
Surge Current Capacity	1.2/50μs & 8/20μs, 3000A, electrically connected with a resistor (4~6 Ω), ±5 times, each time interval 60 seconds. Thereafter, outer appearance shall be visually examined.	No crack and no failures
Cold Resistance	Measurement after -40°C/1000 HRS & normal temperature/2 HRS.	Features are conformed to rated spec.
Heat Resistance	Measurement after 125°C/1000 HRS & normal temperature/2 HRS.	
Humidity Resistance	Measurement after humidity 90~95°C (45°C) /1000 HRS & normal temperature/2 HRS.	
Temperature Cycle	10 times repetition of cycle -40°C/30min → normal, temp/2 min → 125°C/30min, measurement after normal temp/2 HRS.	
Solder Ability	Apply flux and immerse in molten solder 230±5°C for 3sec up to the point of 1.5mm from body. Check for solder adhesion.	Lead wire is evenly covered by solder.
Solder Heat	Measurement after lead wire is dipped up to the point of 1.5mm from body into 260±5°C solder for 10sec.	Conformed to rated spec.
Pull Strength	Apply 0.5kg load for 10sec.	Lead shall not pull out to snap.
Flexural Strength	Bend lead wire at the point of 2mm from body under 0.25 load and back to its original point. Repeat 1 time.	

Recommended Soldering Conditions

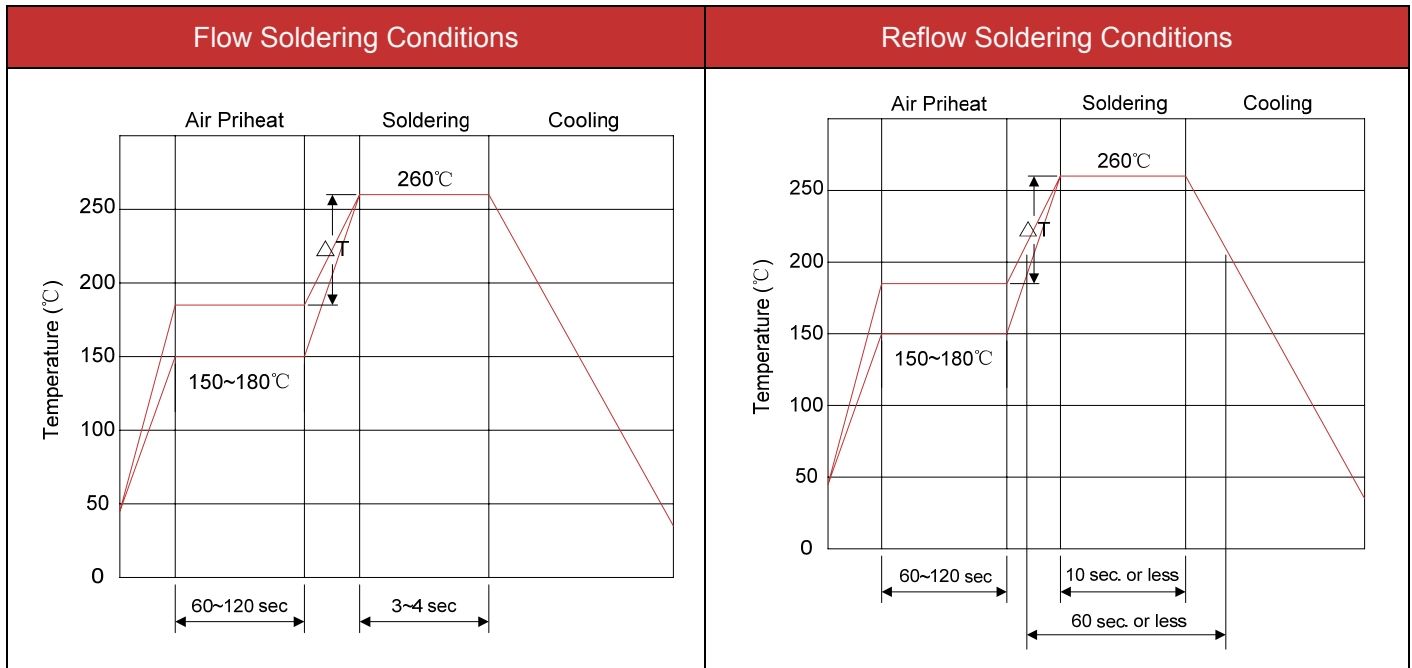

- 1) Time shown in the above figures is measured from the point when chip surface reaches temperature.
- 2) Temperature difference in high temperature part should be within 110°C.
- 3) After soldering, do not force cool, allow the parts to cool gradually.

Hand Soldering

Solder iron temperature: 350±5°C
 Heating time: 3 seconds max.

General attention to soldering

- High soldering temperatures and long soldering times can cause leaching of the termination, decrease in adherence strength, and the change of characteristic may occur.
- For soldering, please refer to the soldering curves above. However, please keep exposures to temperatures exceeding 200°C to fewer than 50 seconds.
- Please use a mild flux (containing less than 0.2wt% Cl). Also, if the flux is water soluble, be sure to wash thoroughly to remove any residue from the underside of components that could affect resistance.

Cleaning

When using ultrasonic cleaning, the board may resonate if the output power is too high. Since this vibration can cause cracking or a decrease in the adherence of the termination, we recommend that you use the conditions below.

Frequency: 40kHz max.
 Output power: 20W/liter
 Cleaning time: 5 minutes max.

Packaging

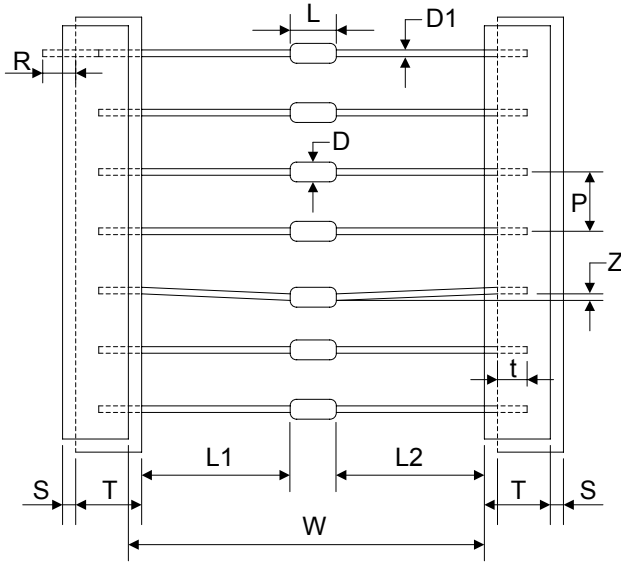
Tape	Symbol	Dimension (mm)
	W	52.0±1.5
	P	5.0±0.5
	L1-L2	1.0max.
	T	6.0±1.0
	Z	1.2max.
	R	Terminals must not project from tape.
	t	3.2max.
	S	0.8max.
	D	Φ3.6max.
	D1	Φ0.5±0.05
	L	5.8max.
	A	78.0
	B	78.0
	C	255.0
	Quantity: 1500PCS	

Inner Box

