

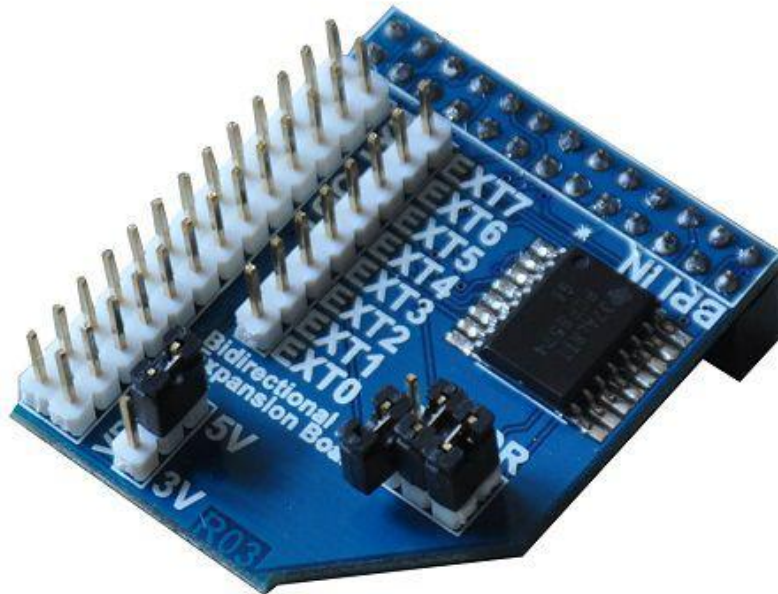

I2C IO Expand Module:





Contact Us

SINOVOIP CO., LIMITED

**Company Add:5/F, Comprehensive Building of Zhongxing
industryCity,Chuangye Road,Nanshan District,
Shenzhen,Guangdong,China**

Version: 1.0

Data: 2014.7.25



Shenzhen SINOVOIP CO., LIMITED Copyright Statement

The document only describes the information about the product. However, it cannot guarantee the product's function and performance. If the document content or the product features and technical specifications included in the document are changed, no further notice will be given.

Content in the document might be outdated. Our cooperation cannot promise to update this information.

Some information in the document might be disabled in your local area, including product and service. You can consult with the contact and agency in your local area.

Copyright in the document belongs to Shenzhen SINOVOIP CO., LIMITED. Users can only use the content after they or she get authorization from our company or other obligee. However, users cannot copy, paraphrase, or create similar devices or products.

The document's final right to interpret and be used for final interpretation belongs to Shenzhen SINOVOIP CO., LIMITED.

More information:

Get more product and support; please contact Shenzhen SINOVOIP CO., LIMITED (www.banana-pi.com)

Attention:

Due to technical requirements of components, please do not touch directly connected

components. The core board and development system contain static-sensitive devices. Quiet electrical charges easily accumulate in the human body, and the device cannot detect possible damage to equipment. It is recommended to take anti-static measures; it is recommended not to touch, store, or use anti-static effect devices.





Banana Pi Expand Module Serial:

Infinity cascade IO expand module:

This module is designed specifically for the Banana Pi IO expansion modules. The module expand 32 IO, Multiple modules can cascade, infinity cascade, infinity GPIO.

I2C GPIO expand module:

This module is designed specifically for the Banana Pi IO expansion modules. The Module use I2C bus to connect to Banana Pi. The module expand 8 Bidirectional GPIO and wit isolation protection function which can effectively excessive external voltage. There are 8 I2C address, you can choose one of them through setup the jumper. Multiple modules can cascade and maximum cascade 8 modules!

Prototype development module:

The Prototype development module is designed specifically for the Banana Pi. The module suitable enthusiasts and user can weld peripheral to the module; The module expand some amphenol connector and some SMT, so the user can finish prototype test easily.

Berryclip expand module:

The BerryClip module is designed specifically for learning how to use the GPIO of Banana Pi. There are 6 multiple color LED, 1 button and 1 Buzzer on the module.

Berryclip(DIY) expand module:

The module is not the end product, you need weld them by yourself. The function of the module is the same as BerryClip module.

UNO compatibility module:

The module makes Banana Pi compatible with Arduino Uno and many Arduino Shields. The module's GPIO is the same as Arduino Uno and you can choose the voltage of GPIO between 5V or 3V through setup jumper.

T Electric level convert module:

The module expand the GPIO of Banana Pi to breadboard. It convert 3.3V electric to 5V electric level, then the Banana Pi can connect many 5V electric level peripheral.

IO extraction module:

The module expand all of GPIO of Banana Pi to breadboard.

Product Specification:

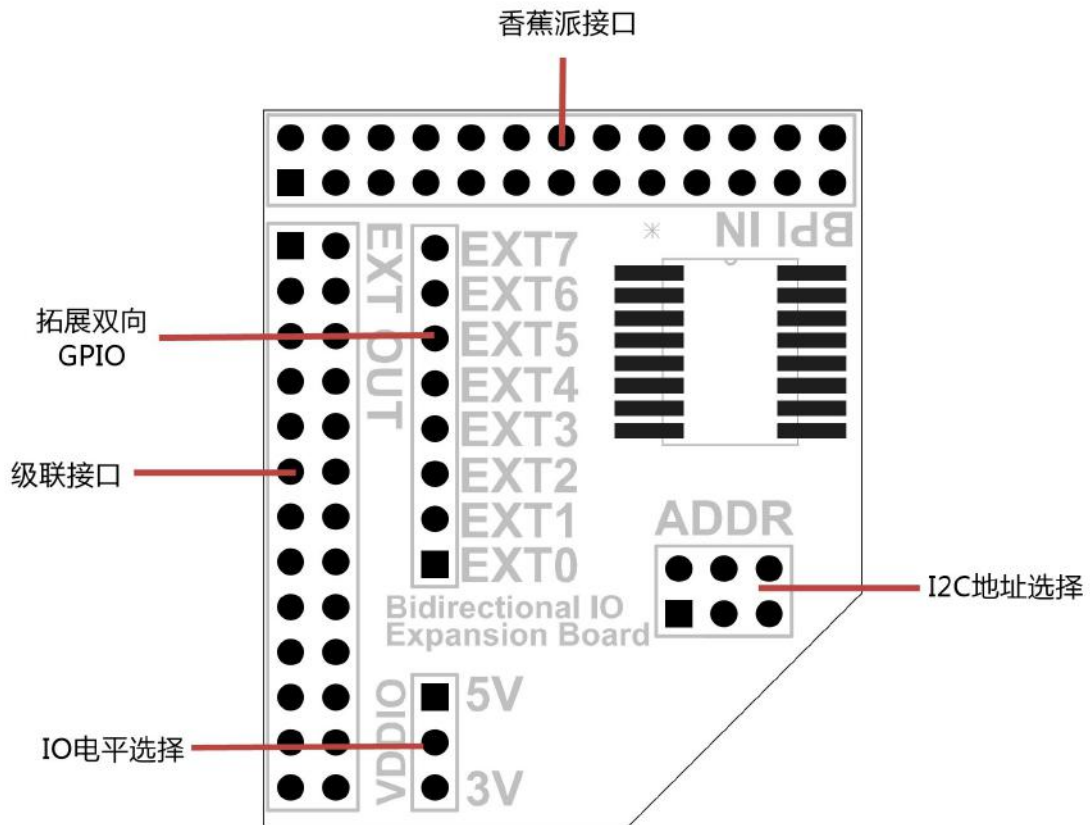

Product Overview:

This module is designed specifically for expand for the GPIO of the Banana Pi a which can effectively solve the banana send IO port insufficient. It use PCF8574 chip to expand 8 Bidirectional IO. The module connection to the Banana Pi through I2C bus. There are 8 I2C address in the module and user can choose one of them through setup the “ADDR” jumper. User also can choose 5V or 3.3V electric level. Module with isolation protection, can effectively prevent external high voltage damage to the Banana Pi. Multiple module can cascade.



Product Features:

- 8 Bidirectional IO
- 8 I2C-address
- Isolation protection
- Use wiringPi API , sample code
- 100 kHz I2C-bus interface (Standard-mode I2C-bus)

Port:

- Banana Pi insert port
- Banana Pi cascade port
- EXT0-EXT7 expand GPIO
- Electric level selection jumper
- I2C-address selection jumper

Product Parameters:

- Working voltage: 2.5V-6V
- IO voltage: 3.3V or 5.5
- Expand 8 Bidirectional IO
- I2C bus
- 100 kHz I2C-bus interface (Standard-mode I2C-bus)
- -40°C to +85°C operation

Typical Application:

- LED signs and displays
- Key pads
- Instrumentation and test measurement
- Driver numeric display
- Drive the lattice screen



How to use:

Insert the module that the silk screen says "BPI IN". Pay attention don't make the direction reversed! The correct direction of insert module is above the Banana Pi's PCB; EXT0-EXT7 are expand GPIO, user can use DuPont Line to connection peripheral. The header which near silk screen write "EXT" expand GPIO of Banana Pi, user can cascade the other module or the same module. If you want switch the electric level, just setup the jumper

More Information:

The PCF8574/74A provides general-purpose remote I/O expansion via the two-wire bidirectional I2C-bus (serial clock (SCL), serial data (SDA)).

The devices consist of eight quasi-bidirectional ports, 100 kHz I2C-bus interface, three hardware address inputs and interrupt output operating between 2.5 V and 6 V. The quasi-bidirectional port can be independently assigned as an input to monitor interrupt status or keypads, or as an output to activate indicator devices such as LEDs. System master can read from the input port or write to the output port through a single register.

The low current consumption of 2.5uA (typical, static) is great for mobile applications and the latched output ports directly drive LEDs.

The PCF8574 and PCF8574A are identical, except for the different fixed portion of the slave address. The three hardware address pins allow eight of each device to be on the same I2C-bus, so there can be up to 16 of these I/O expanders PCF8574/74A together on the same I2C-bus, supporting up to 128 I/Os (for example, 128 LEDs).

The active LOW open-drain interrupt output (INT) can be connected to the interrupt logic of the microcontroller and is activated when any input state differs from its corresponding input port register state. It is used to indicate to the microcontroller that an input state has changed and the device needs to be interrogated without the microcontroller continuously polling the input register via the I2C-bus.

The internal Power-On Reset (POR) initializes the I/Os as inputs with a weak internal pull-up 100uA current source.



Address Table:

Pin connectivity			Address of PCF8574							Address byte value		7-bit hexadecimal address without R/W	
A2	A0	A1	A6	A5	A4	A3	A2	A1	A0	R/W	WRITE	READ	
VSS	VSS	VSS	0	1	0	0	0	0	0	-	40h	41h	20h
VSS	VSS	VDD	0	1	0	0	0	0	1	-	42h	43h	21h
VSS	VDD	VSS	0	1	0	0	0	1	0	-	44h	45h	22h
VSS	VDD	VDD	0	1	0	0	0	1	1	-	46h	47h	23h
VDD	VSS	VSS	0	1	0	0	1	0	0	-	48h	49h	24h
VDD	VSS	VDD	0	1	0	0	1	0	1	-	4Ah	4Bh	25h
VDD	VDD	VSS	0	1	0	0	1	1	0	-	4Ch	4Dh	26h
VDD	VDD	VDD	0	1	0	0	1	1	1	-	4Eh	4Fh	27h

Timing Diagram:

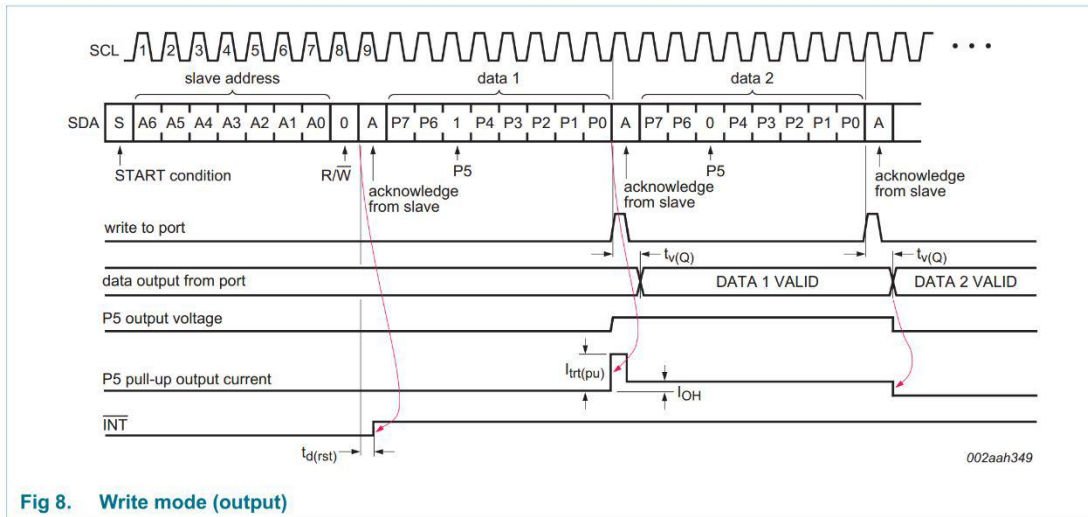

Fig 8. Write mode (output)



Testbench:

- Use: `sudo i2cdetect -y -a 1` check the I2C-address
- Use wiringPi API, initialize module
- Setup IO to OUTPUT mode, 5V high level and check the level of the state with a multimeter
- Setup IO to OUTPUT mode, 3V high level and check the level of the state with a multimeter
- Setup IO to INPUT mode, input 5V high level and check the IO status through wiringPi
- Setup IO to INPUT mode, input 3V high level and check the IO status through wiringPi
- Finish test

Schematic diagram:

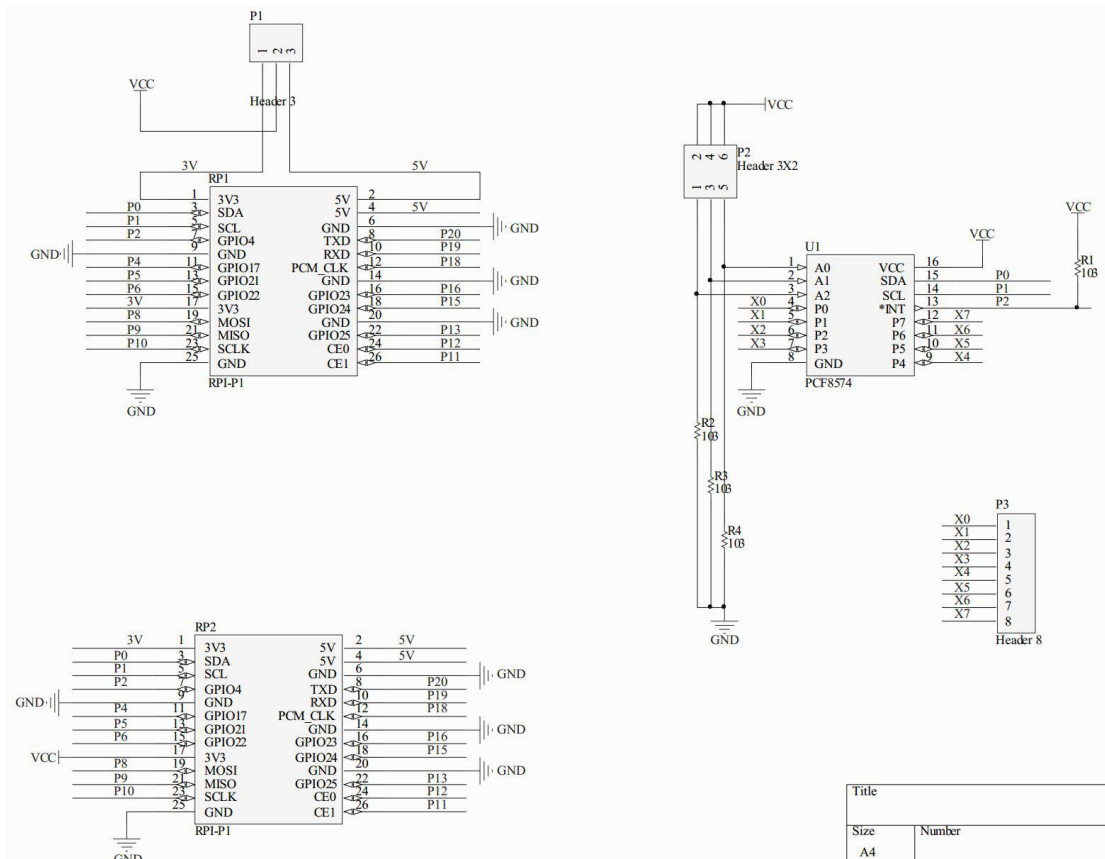

More information please check:

http://www.nxp.com/products/interface_and_connectivity/i2c/i2c_general_purpose_i_o/PCF8574T.html

www.banana-pi.com

I2C IO Expand Module Datasheet



Example and Test Code (wiringPi):

```
#include <wiringPi.h>
#include <pcf8574.h>
#include <stdio.h>
int main()
{
    int i;
    pcf8574Setup(100,0x27);
    for(i=0;i<8;i++) pinMode(100+i,OUTPUT);
    while(1)
    {
        i = 0;
        for(i=0;i<=8;i++)
        {
            printf("Current LED = %d\n",100+i);
            digitalWrite((100+i),HIGH);
            delay(500);
            digitalWrite((100+i),0);
            delay(500);
        }
    }
}
```