

COIL FORMER
General data EF16 cap

PARAMETER	SPECIFICATION
Case material	liquid crystal polymer (LCP), glass reinforced, flame retardant in accordance with "UL 94V-0"; UL file number E41938
Maximum operating temperature	155°C, "IEC 60085", class F
Resistance to soldering heat	"IEC 60068-2-20", Part 2, Test Tb, method 1B, 350 °C, 3.5 s
Soldeerability	"IEC 60068-2-20", Part 2, Test Ta, method 1

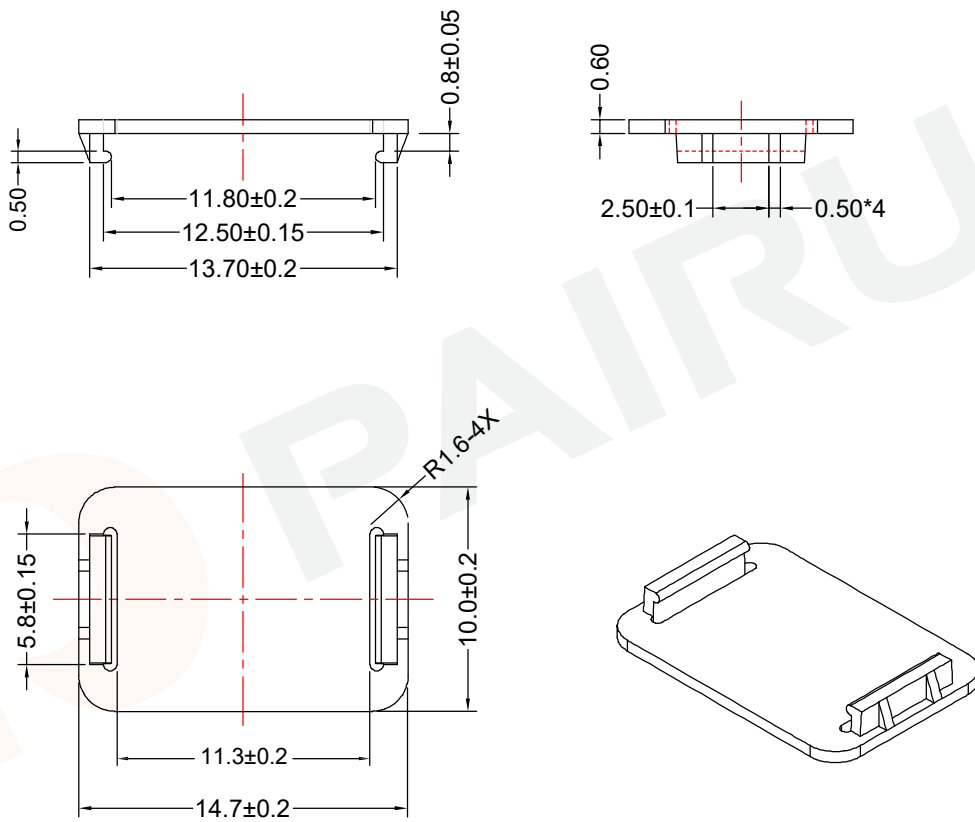

Tolerances unless otherwise specified:
 $0 < L \leq 4 \pm 0.10$ $4 < L \leq 16 \pm 0.20$
 $16 < L \leq 45 \pm 0.30$ $45 \leq L \pm 0.40$
 Pin Dim: ± 0.05 Thickness: ± 0.20 Pin Pitch: ± 0.20

Dimensions:
(mm)

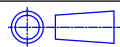

TYPE NUMBER: SMD-EF-1601C

Mould No.:

material: LCP-E4008

Code No.: FAY01029

Available for Fuan core:



Fuan Electronics

TEL :0086-514-87693589
 EML :sales@fuantronics.net
 WEB:www.fuantronics.net

Make: P.Xiao

Material Number: A41160000080

Checked: Beson. zhan

Document/Rev: 00

Approved: Anson. zhan

Date of Recognition: Dec./09/2019