

SECTION B-B
SCALE 1 : 4

M5.5X8 mm TAPPING SCREWS
(NOT SUPPLIED)

TEN (10) M4X25 mm
PAN HEAD SCREWS.

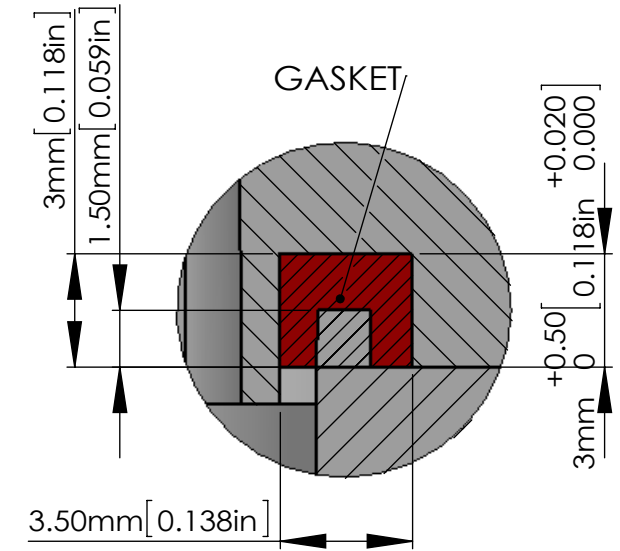
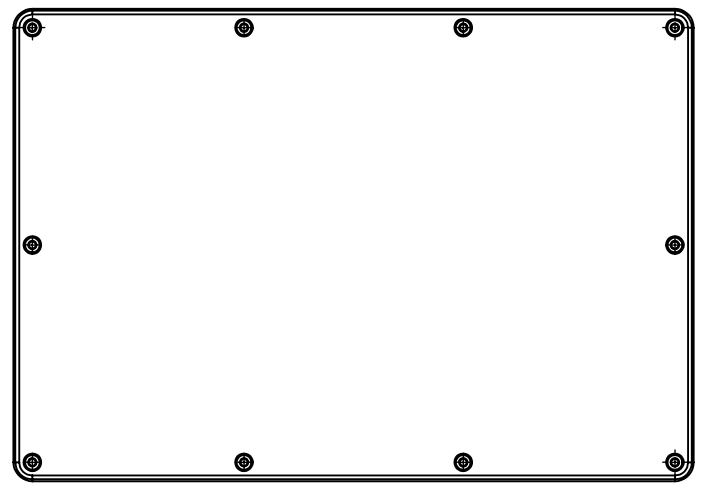
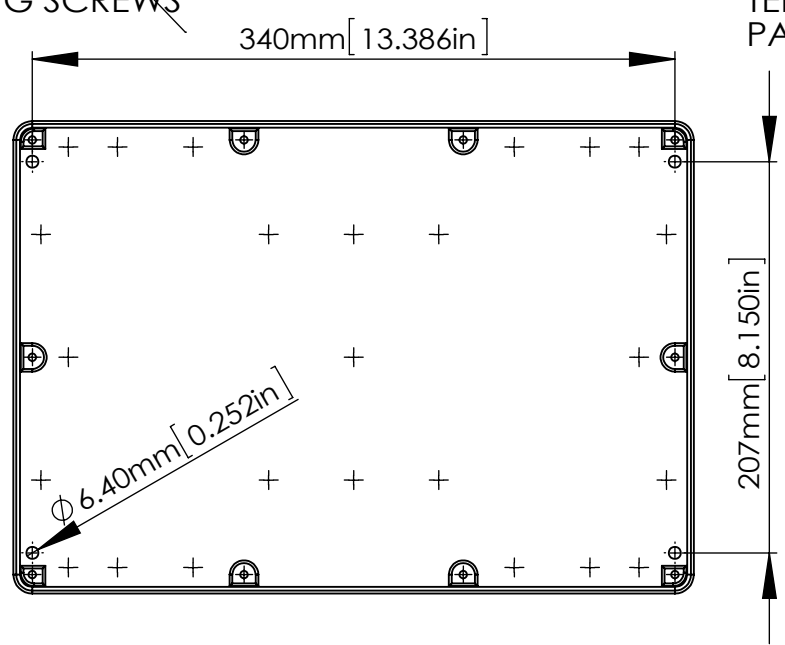

SECTION C
SCALE 5 : 1

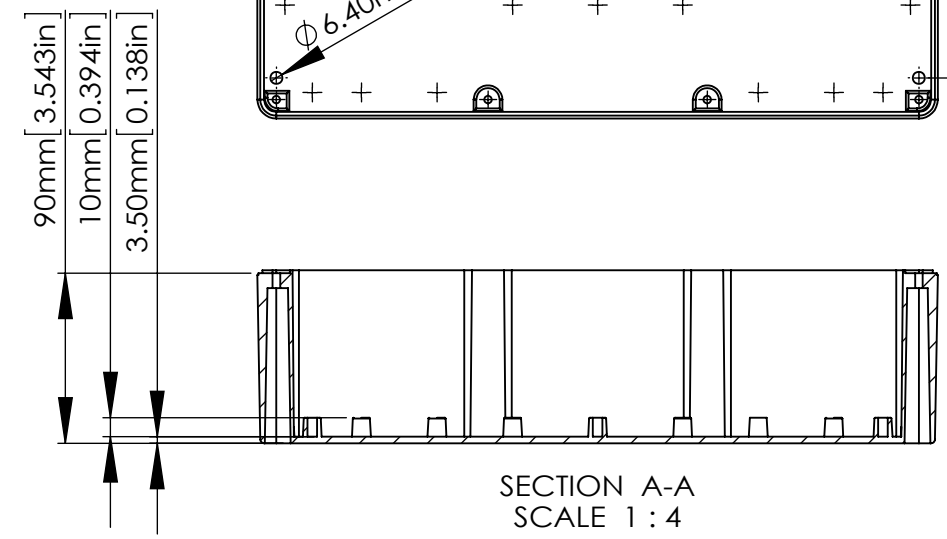

SECTION A-A
SCALE 1 : 4

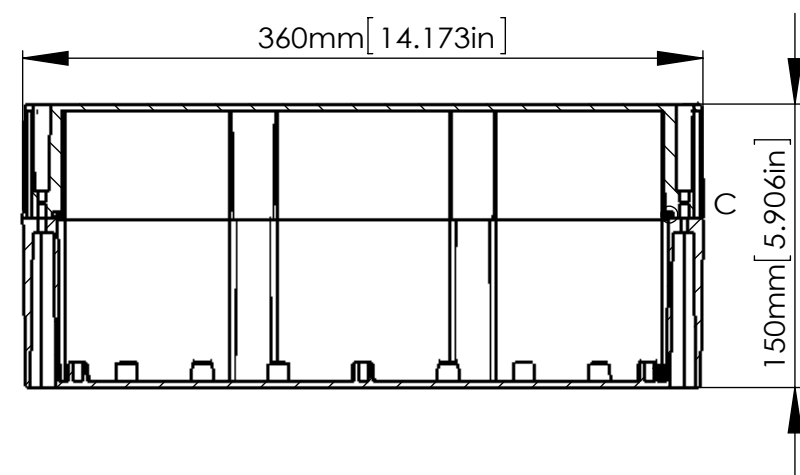

According to ISO 2768-m	
Measuring DIM=L	Tolerances
0.5<L<=3.0mm	±0.1mm
3.0<L<=6.0 mm	±0.1mm
6.0<L<=30.0 mm	±0.2mm
30.0<L<=120.0 mm	±0.3mm
120.0<L<=400.0 mm	±0.5mm
400.0<L<=1000.0 mm	±0.8mm

宣又實業有限公司
GAINTA INDUSTRIES LTD.

繪圖 DRA'D BY
JACKY

日期 DATE
2024/07/17

材質 MATE.
PC/ABS

圖名TITLE:
G20883-IP67;G30993-IP67

圖號DWG NO:

版次REVISED:
A