



Features :

- Constant voltage mode power supply
- Universal AC input / Full range
- Fully encapsulated with IP67 level
- Protections: Short circuit/Over current
- Built-in active PFC function
- Small and compact size
- UL1310 Class 2 power unit
- 100% full load burn-in test
- Suitable for LED lighting and moving sign applications
- 2 years warranty

SPECIFICATION:

MODEL		LV35P-12	LV35P-24
OUTPUT	DC VOLTAGE	12V	24V
	RATED CURRENT	3.0A	1.5A
	CURRENT RANGE	0~3.0A	0~1.5A
	RATED POWER	36W	36W
	RIPPLE & NOISE (max.)	5Vp-p	5Vp-p
	VOLTAGE TOLERANCE	±3.0%	
	LINE REGULATION	±1.0%	
	LOAD REGULATION	±2.0%	
SETUP,RISE TIME	1500ms,250ms/230VAC 3000ms,250ms/115ac at full load		
INPUT	VOLTAGE RANGE	100-240VAC	
	FREQUENCY RANGE	47~63Hz	
	EFFICIENCY(Typ.)	82% full load	84% full load
	POWER FACTOR	PF>0.9/230VAC PF>0.95/115VAC at full load	
	AC CURRENT	0.6A/100AC	0.3A/240VAC
	INRUSH CURRENT (max.)	COLD STAT 70A/230VAC	
LEAKAGE CURRENT	0.5mA/240VAC		
PROTECT ON	OVER CURRENT/ SHORT CIRCUIT	Above 150% ~200%rated output power or short circuit. Protection type: Hiccup mode, recovers automatically after fault condition is removed.	
	OVER VOLTAGE	Protection type:110% ~150%, shut off, recovers automatically after fault condition is removed.	
	OVER TEMPERATURE	Tj 140℃ typically(IC1) Detect on main control IC Protection type: Hiccup mode, recovers automatically after temperature goes down	
ENVIRONMENT	WORKING TEMP.	-10~50℃	
	WORKING HUMIDITY	20~90% RH non-condensing	
	STORAGE TEMP., HUMIDITY	-40~80℃, 10~95% RH	
	TEMP.COEFFICIENT	±0.03%/℃ (0~50℃)	
	VIBRATION	10 ~ 500Hz, 2G 10min./1cycle, period for 60min. each along X,Y, Z axes	
SAFETY & EMC	SAFETY STANDARDS	Design refer to UL1310 Class 2,TUV EN60950-1, EN61347-2-13, CAN/CSA C22.2 No. 223-M91, meet IP67	
	WITHSTAND VOLTAGE	I/P-O/P:3KVAC	
	ISOLATION RESISTANCE	I/P-O/P:>100M Ohms / 500VDC / 25~70% RH	
	EMI CONDUCTION & RADIATION	Compliance to EN55022 (CISPR22) Class B	
	HARMONIC CURRENT	Compliance to EN61000-3-2,-3	
EMS IMMUNITY	Compliance to EN61000-4-2,3,4,5,6,8,11; ENV50204, EN55024, light industry level, criteria A		
DIMENSION	148*32*28mm (L*W*H)		

Mechanical Specification

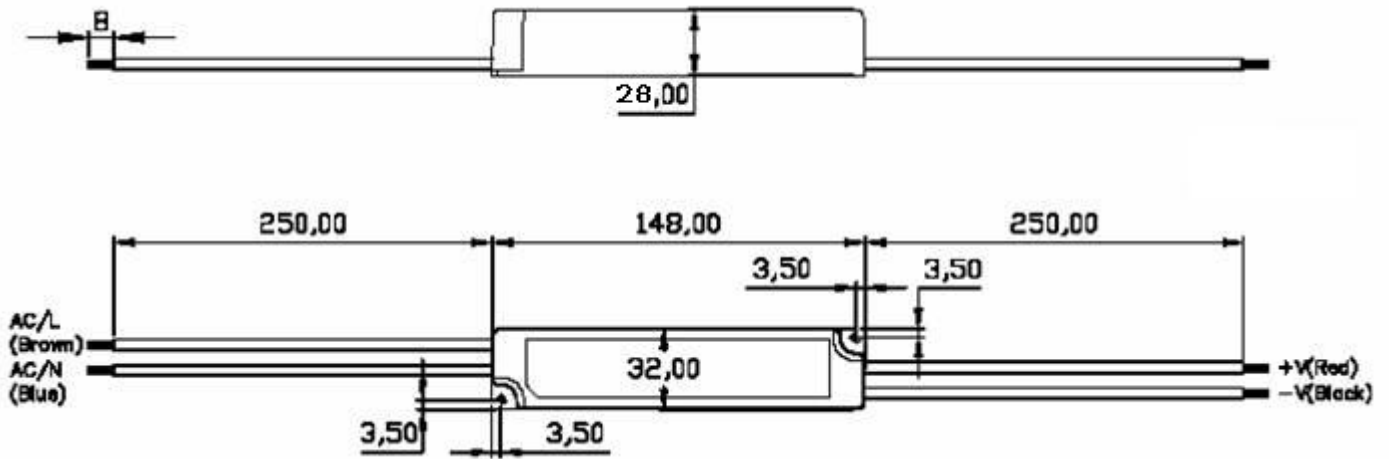

Block Diagram

