



产品规格书

SPECIFICATION

产品型号 Model. P/N NO.: LN-SMD3838UV-P1(60DEG)

文件编号 Document. NO.:

版 次 REV. NO.:

送承日期 Documents. NO.: 2017-09-12

描述 Description:

- 3.8×3.8mm 垂直 UVA 贴片光源 3.8x3.8mm Vertical UVA LED
- 基板材质 Substrate material: 氮化铝陶瓷 ALN+Coppering ceramics
- 封装材料 Housing Material: 石英玻璃 Quartz glass

深圳市联佑光电		客户/Customer (加盖公章)		
技术部/TD		市场部/MKT Dept	公司名称/Customer name:	
制作 Maker	审核 Checked	业务员 Salesman	技术部 Technique department	采购部门 Purchasing Department

地址: 深圳市光明新区凤凰街道甲子塘第二工业区 2 号 A 栋 3 楼

Add: 3F,Block A,No 2,2nd industry estate of Jiazitang,Phoenix street, Guangming Dist ,Shenzhen City.

Tel/电话 : 0755--29084995

Fax/传真 : 0755--23224565

Web/网址 : <http://www.learnnew-led.com>



1. 外形尺寸 Dimensions

单位(Units):毫米(mm)

俯视图

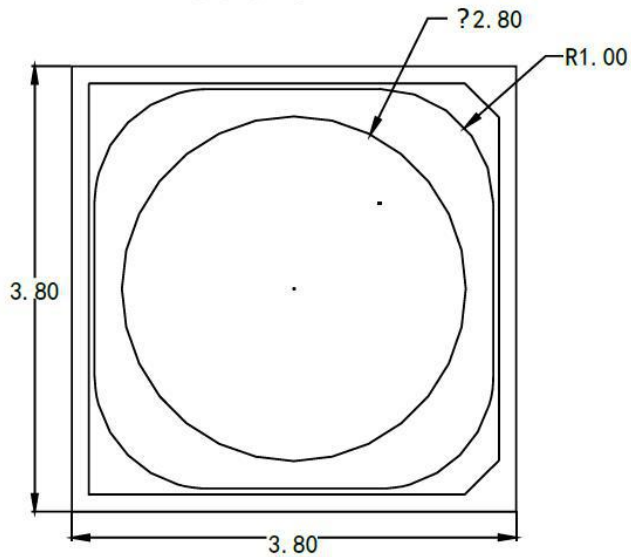

仰视图

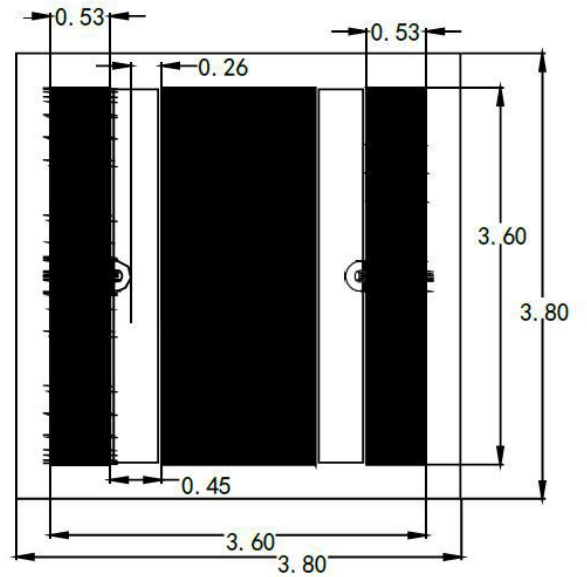

侧视图

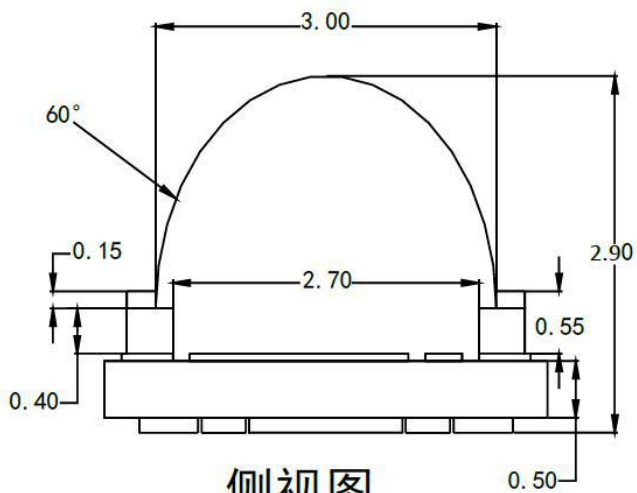

备注/Postscript:

所有尺寸单位为 mm ， 如无特殊说明误差范围为 ± 0.05 mm

All dimensions area in mm tolerance is ± 0.1 mm unless otherwise noted.



2. 光电特性 Electrical / Optical characteristics

(1) 极限参数 Absolute Maximum Ratings

项目/Item	符号/Symbol	数值/Value	单位/Unit
峰值电流 Peak Current	IF	1000	mA
工作温度 Operating Temperature	Topr	-40°C To +80°C	°C
结点温度 Junction Temperature	Tj	120	°C
储存温度 Storage Temperature	Tstg	-40°C To +100°C	°C
静电击穿电压 ESD Sensitivity	~	±2,000V HBM	V
反向电压 Reverse Voltage	VR	5	V
反向电流 Reverse Current	IR	10	uA
直流脉冲电 DC Pulse Current (@ 1 KHz ; 1/10 Duty Cycle)	IFP	1200	mA
焊接温度 Soldering Temperature	Tsld	Reflow Soldering : 260°C Hand Soldering : 350°C	for 10sec. for 3sec.

(2) 光电特性 Electrical / Optical characteristics

IF=700mA Ta=25°C

项目 Item	符号 Symbol	最小值 Min.	规格值 Typ.	最大值 Max.	单位 Units	条件 Condition
正向电压 Forward Voltage	VF	3.2	--	4.0	V	IF=700mA
正向电流 Forward Current	IF	--	700	1000	mA	--
峰值波长 Peak wavelength	nm	365	--	395	nm	IF=700mA
光功率 Optical power	P	810	--	1020	MW	PW=365nm
		1000	--	1200		PW=385nm
		1050	--	1250		PW=395nm
发光角度 Viewing Angle	2θ1/2	--	60	--	deg.	IF=700mA
热阻 Thermal Resistance	RθJ-B	--	1.2	--	°C/W	IF=700mA



3.典型特性曲线/Typical Characteristic Curves

(1) .典型光谱分布

Typical spectral distribution

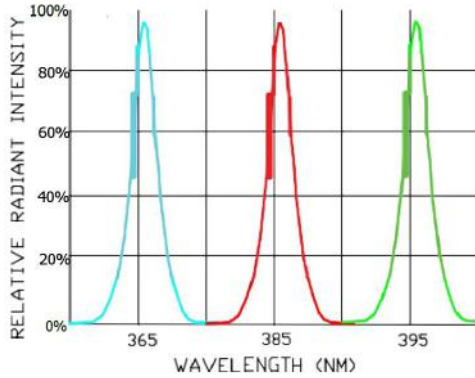

(2) .典型发光角度辐射图

Typical Light-Emitting Angle Radiation Pattern

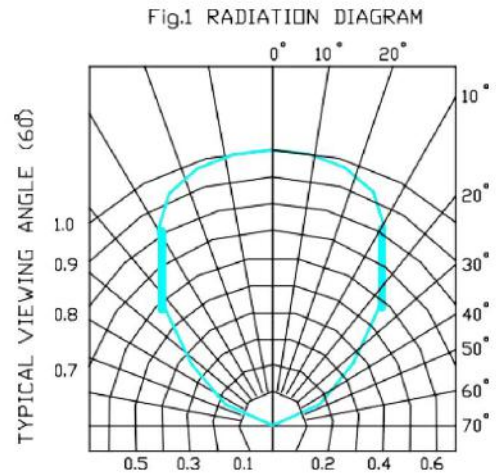

(5) .电性特征曲线图($T_j = 25^\circ\text{C}$)

Electrical Characteristics Curve

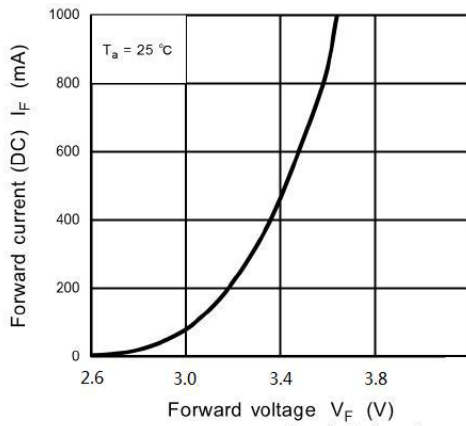

(4) .输出光通量与温度曲线

Relative Flux vs. Temperature

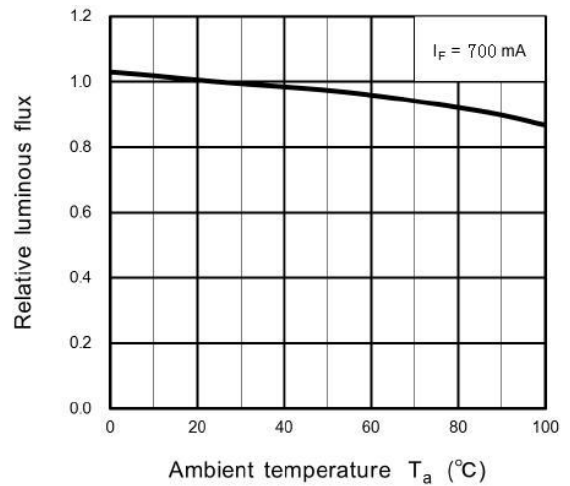



4. 可靠性试验/Reliability Test Items And Conditions

测试项目及结果 Test Items and Results

项目 Test Items	测试条件 Test Condition	时间 Time	数量 Quantity	接收/拒收 Ac/Re
常温通电 Life Test	Ta=25°C±5°C IF=700mA	3 times.	22Pcs.	0/1
高温点亮 High Temperature Life Test	Temp:85°C±5°C	1000Hrs.	22Pcs.	0/1
高温高湿通电 High Temperature High Humidity Life Test	85°C±5°C/ 85%RH IF=700mA	1000Hrs.	22Pcs.	0/1
温度循环 Temperature Cycle	100°C±5°C 30 min. ↑↓5 min -40°C±5°C 30 min.	200 Cycles.	22Pcs.	0/1
回流焊 Reflow	Temp:260°C max T=10 sec	3 times.	22Pcs.	0/1
硫化实验 Curing Experiments	水: 硫=100:0.5 Temp:85°C±5°C	6Hrs.	22Pcs.	0/1

失效判定标准 Criteria For Judging Damage

项目 Test Items	测试条件 Test Condition	判定标准 Criteria For Judgement	
		Min. 最小	Max. 最大
正向电压 Forward Voltage	IF=700mA	/	U.S.L*)x1.1
反向电流 Reverse Current	VR=10V	/	U.S.L*)x2.0
光通量 Luminous Flux	IF=700mA	L.S.L*)x0.7	/



5.注意事项/Cautions

(1) 焊接条件 Soldering Conditions

本产品建议最多只可回焊两次,且在首次回焊后须冷却至室温之后方可进行第二次回焊.

Number of reflow process shall be less than 2 times and cooling process to normal temperature is required between first and Second soldering process.

推荐焊接条件(Recommended soldering conditions)

回流焊接 Reflow Soldering		手工焊接 Hand Soldering	
预热温度Pre-heat 预热时间 Pre-heat time 峰值温度 Peak temperature 焊接时间 Soldering time 条件Condition	有铅 Lead Solder 140 ~ 160°C 120 sec. Max. 230°C Max. 10 sec. Max. 参考下图	无铅 Lead-free Solder 180 ~ 200°C 120 sec. Max. 260°C Max. 10 sec. Max. 参考下图	温度Temperature 焊接时间Soldering time 360°C Max. 3 sec. Max. (one time only)

有铅回焊 (Lead Solder)

无铅回焊 (Lead-Free Solder)

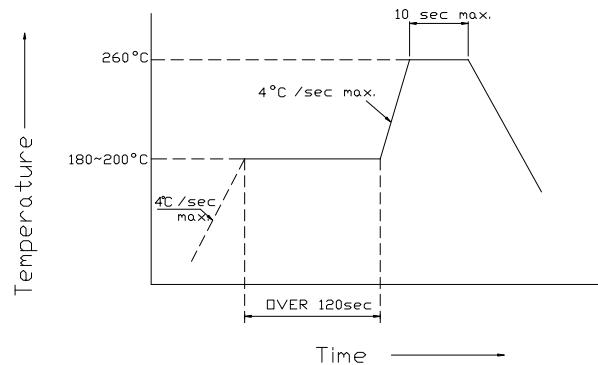
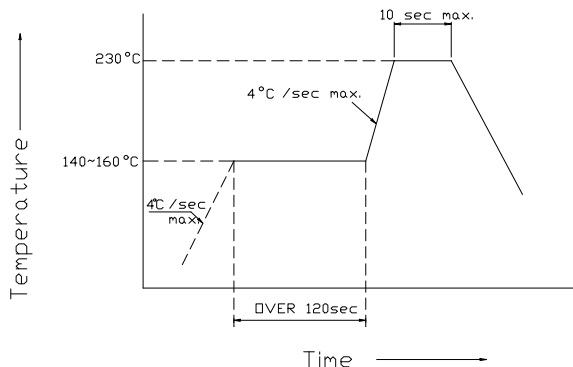

(2)防潮包装 Moisture Proof Package

使用防潮包装

It is recommended that moisture proof package be used .

(3)储藏 Storage

打开包装袋之前,LED 在温度为 30°C 或更低湿度 60%RH 以下,可保存一年.

Before opening the package ,The LEDs should be kept at 30°C or less and60%RH or less. The LEDs should be used within a year.

(5)打开包装之后,应在 24hrs 内焊接完毕.

After opening the package, The LEDs should be soldered within 24 hours (1days) after opening the package.

(6)使用注意事项 Cautions:

6.1.在开包装之前,请先检查包装袋有无漏气,如果有漏气现象,请退回我司重新烘烤除湿包装后再使用。

Please check if there is air leak before opening the package, if so, please return the goods back to take drying process for later using.

6.2 抽真空包装材料未超过 30 天可正常使用, 包装袋开启后,产品必须:



Products can be used within 15days after packaging, after that, they must be:

6.2.1 在 24hrs 内未焊接完毕。

Soldered within 24 hrs

6.2.2 要在规定环境条件中使用: 温度:30°C以内 湿度:60%RH 以下

Used in the condition: 30°C within and 60%RH below

6.2.3 存储低于 30%RH。

Stored in 30%RH for moisture below.

6.3.材料拆装后使用时间超过 24H 未用完, 需烘烤 75°C/3H 除湿后才可使用。

Products not be used after opening the package need to be dried out for 75°C/3H

6.4.此产品设计不针对下列任何条件, 如在下列任何条件下使用产品, 请确定其正常性能和可靠性;

如: 潮湿, 有露水凝霜, 盐水空气, 腐蚀性气体的地方 (C1,H2S,NH3,SO2,NOX,等); 太阳直晒下, 户外暴露, 多灰尘的地方。水中, 油, 医用液体和有机溶剂等。

This product design is not targeted at any of the following conditions, such as the use of the product in any of the following conditions, make sure the normal performance and reliability;Such as: wet with dew, frost, salt air, corrosive gases (C1, H2S, where NH3, SO2, NOX); Exposure to the sun under, Outdoor exposure, Dusty place. Water, oil, medical liquid and organic solvent.

6.5.如果 led 光源使用超出规定的正向电流或散热系统不够良好时, 有可能会增加产品失效率或衰减过高现象, 请使用合适的驱动电流和散热体, 以避免产品存在品质隐患。

If the LED light source used in excess of the prescribed forward current or cooling system is not enough good, may increase the product failure rate or attenuation phenomenon, please use the drive current and the radiating body fit, in order to avoid products are quality hidden danger.

6. 包装/Packaging

(1).装带规格 Taping Specifications (单位:毫米 Units:mm)

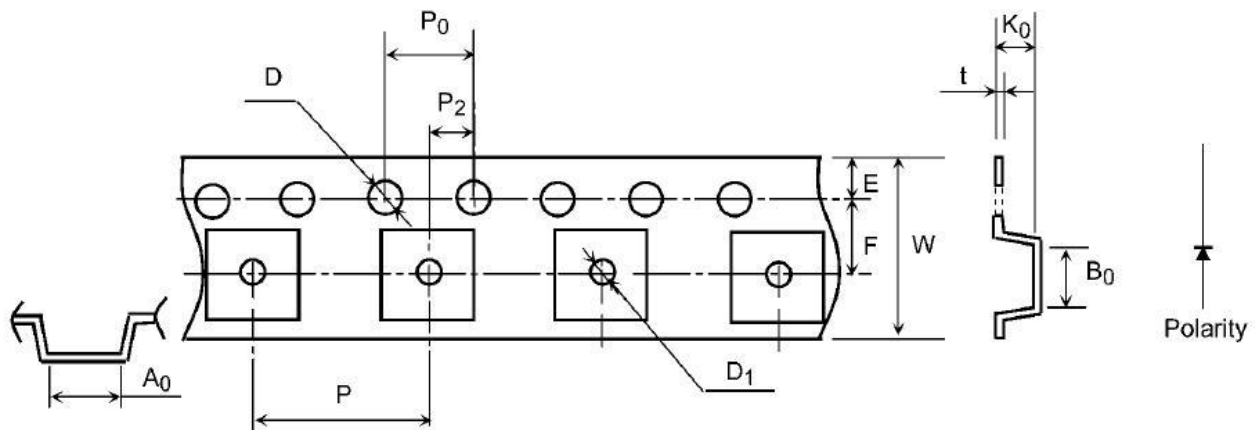



(2). 卷轴尺寸 Reel Dimension

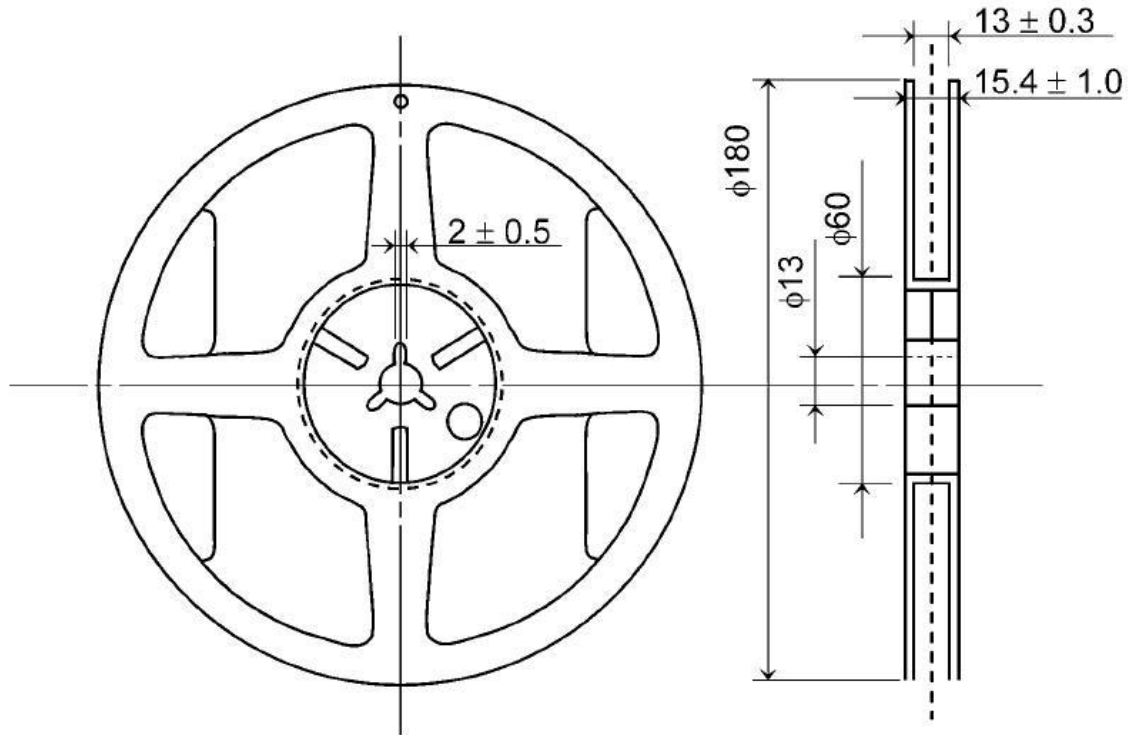

每卷数量 800 个/卷. Package: 800Pcs/Reel

(3). LED 在装带之后纸箱包装. The LED are packed in cardboard boxes after taping.

(4). 最小包装标签注明以下: 产品名称. 批号. 参数范围. 数量.

The label on the minimum packing unit shows ; Part Number, Lot Number, Ranking, Quantity.

(5). 请注意防水防潮 . Keep away from water, moisture in order to protect the LEDs.

(6). 须采取适当防护措施, 以防包装箱跌落或受到强力撞击造成对产品的损伤.

The LEDs may be damaged if the boxes are dropped or receive a strong impact against them. so precautions must be taken to prevent any damage.