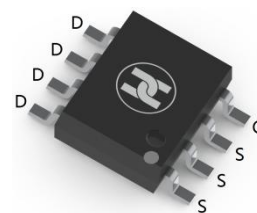
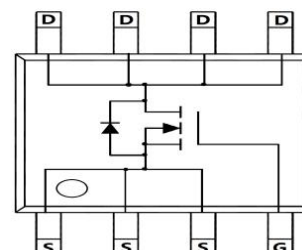

HIGH VOLTAGE MOSFET (N-CHANNEL)
FEATURES

- Ultra low on-resistance: $V_{DS}=100V, I_D=8.9A, R_{DS(ON)} \leq 14m\Omega @ V_{GS}=10V$
- Low Input Capacitance and Fast Switching Speed
- High Conversion Efficiency
- For Back-lighting, DC-DC Converters and Power Management Functions
- Surface Mount device

SOP-8

MECHANICAL DATA

- Case: SOP-8
- Case Material: Molded Plastic. UL flammability
- Classification Rating: 94V-0
- Moisture Sensitivity: Level 1 per J-STD-020
- Weight: 0.3 grams (approximate)

MAXIMUM RATINGS ($T_A = 25^\circ C$ unless otherwise noted)

Parameter	Symbol	Value	Unit
Drain-source voltage	V_{DS}	100	V
Gate-source voltage	V_{GS}	± 20	V
Continuous drain current(2), $V_{GS} = 10V$	I_D	$T_A = 25^\circ C$	8.9
		$T_A = 70^\circ C$	7.1
Pulsed drain current(10 μs Pulse, Duty Cycle = 1%)	I_{DM}	54	A
Maximum Continuous Body Diode Forward Current (2)	I_S	3	A
Avalanche current(4), $L=0.3mH$	I_{AS}	7.5	A
Avalanche energy(4), $L=0.3mH$	E_{AS}	85	mJ
Power dissipation(1)	P_D	1.2	W
Thermal resistance from Junction to ambient (1)	$R_{\theta JA}$	100	$^\circ C/W$
Power dissipation(2)	P_D	1.67	W
Thermal resistance from Junction to ambient (2)	$R_{\theta JA}$	75	$^\circ C/W$
Thermal resistance from Junction to case (2)	$R_{\theta JC}$	12	$^\circ C/W$
Operating and Storage temperature	T_J, T_{STG}	-55 ~ +150	$^\circ C$

ELECTRICAL CHARACTERISTICS ($T_A = 25^\circ C$ unless otherwise specified)

Parameter	Symbol	Min	Typ	Max	Unit	Conditions
Drain-Source breakdown voltage(3)	$V_{(BR)DSS}$	100			V	$V_{GS}=0V, I_D=1mA$
Zero gate voltage drain current(3)	I_{DSS}			1	μA	$V_{DS}=80V, V_{GS}=0V$
Gate-body leakage current(3)	I_{GSS}			± 100	nA	$V_{DS}=0V, V_{GS}=\pm 20V$
Gate-threshold voltage (3)	$V_{GS(th)}$	1.4	2	3	V	$V_{DS}=V_{GS}, I_D=250\mu A$
Drain-source on-resistance (3)	$R_{DS(ON)}$		11.5	14	m Ω	$V_{GS}=10V, I_D=20A$
			15	18	m Ω	$V_{GS}=6V, I_D=20A$
			17.5	25	m Ω	$V_{GS}=4.5V, I_D=5A$
Diode forward voltage (3)	V_{SD}	0.9	1.3		V	$I_S=20A, V_{GS}=0V$
Input capacitance(4)	C_{iss}		1871		pF	$V_{DS}=50V, V_{GS}=0V, f=1MHz$
Output capacitance(4)	C_{oss}		261		pF	
Reverse transfer capacitance(4)	C_{rss}		7		pF	
Gate resistance(4)	R_g		0.75		Ω	$V_{DS}=0V, V_{GS}=0V, f=1MHz$
Total gate charge(4)	Q_g		33.3		nC	$V_{DD}=50V, V_{GS}=10V, I_D=10A$
Gate-source charge(4)	Q_{gs}		6.9		nC	
Gate-drain charge(4)	Q_{gd}		5.1		nC	
Turn-on delay time(4)	$t_{d(on)}$		6.5		nS	$V_{DD}=50V, V_{GS}=10V, I_D=10A, R_g=6\Omega$
Turn-on rise time(4)	t_r		7		nS	
Turn-off delay time(4)	$t_{d(off)}$		19.7		nS	
Turn-off fall time(4)	t_f		8.1		nS	
Body Diode Reverse Recovery Time(4)	t_{rr}		37.9		nS	$I_f=10A, di/dt=100A/\mu s$
Body Diode Reverse Recovery Charge(4)	Q_{rr}		51.9		nC	

- Notes: 1. Device mounted on FR-4 PC board, with minimum recommended pad layout, single sided.
2. Device mounted on FR-4 substrate PC board, 2oz copper, with thermal bias to bottom layer 1inch square copper plate
3. Short duration pulse test used to minimize self-heating effect.
4. Guaranteed by design. Not subject to product testing.

HIGH VOLTAGE MOSFET (N-CHANNEL)

Typical Characteristics

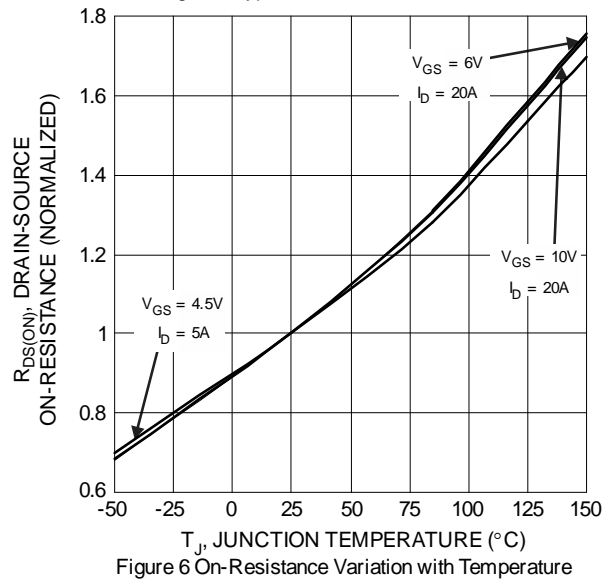
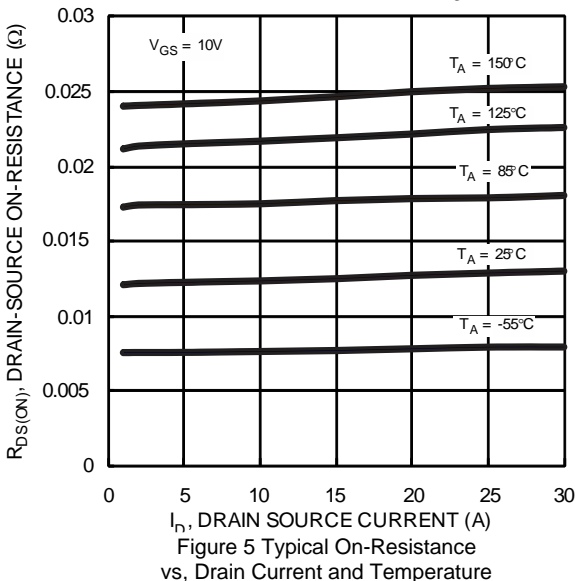
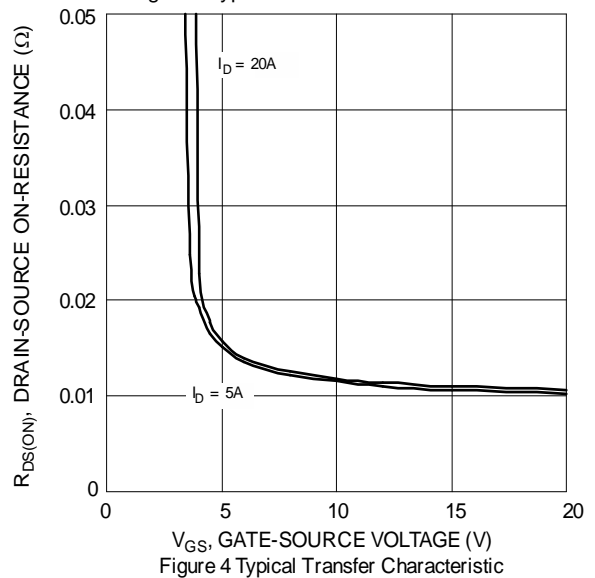
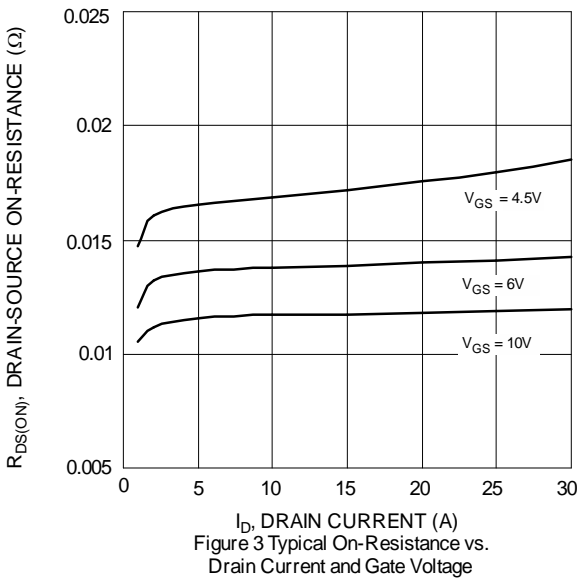
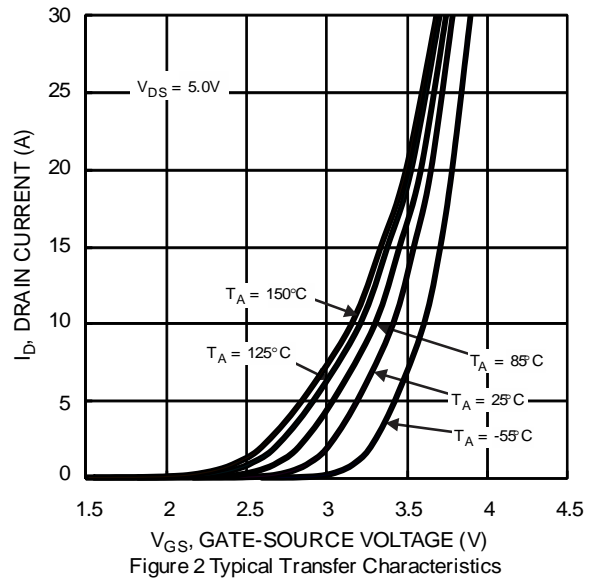
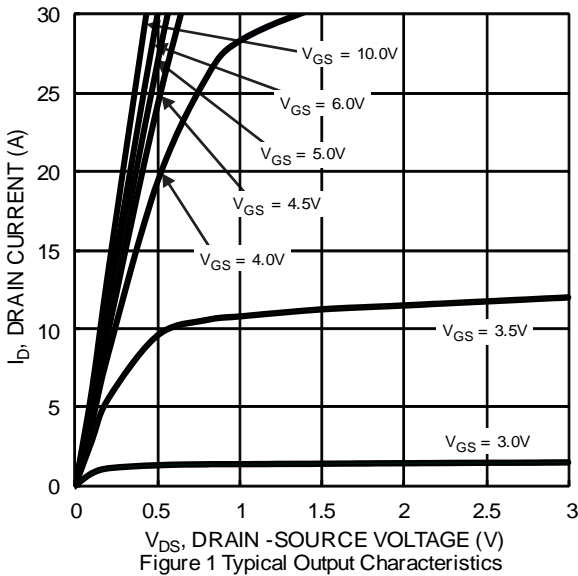

HIGH VOLTAGE MOSFET (N-CHANNEL)

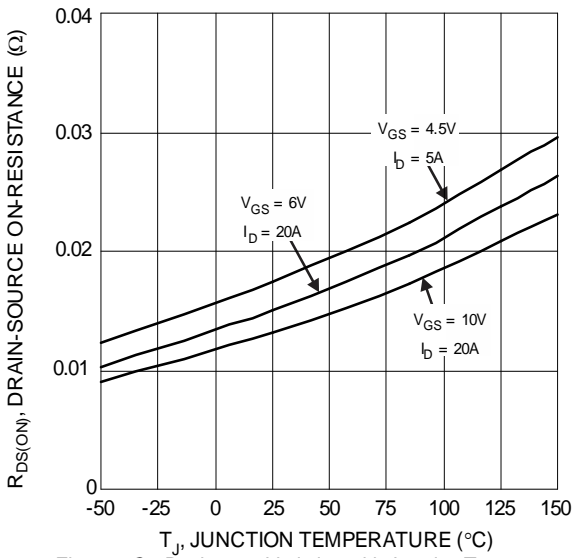

Figure 7 On-Resistance Variation with Junction Temperature

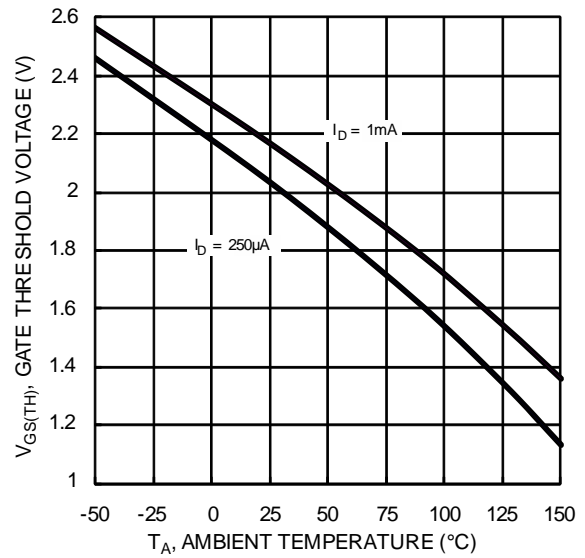

Figure 8 Gate Threshold Variation vs. Ambient Temperature

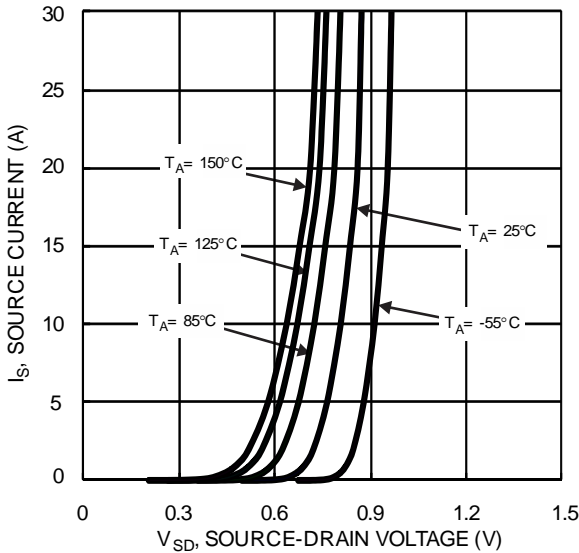

Figure 9 Diode Forward Voltage vs. Current

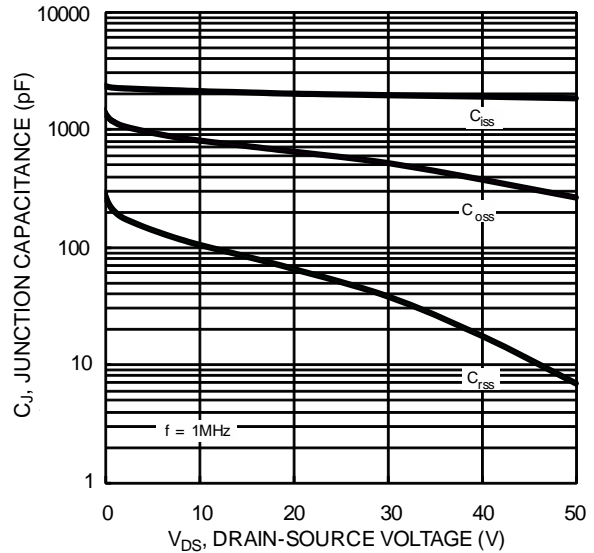

Figure 10 Typical Junction Capacitance

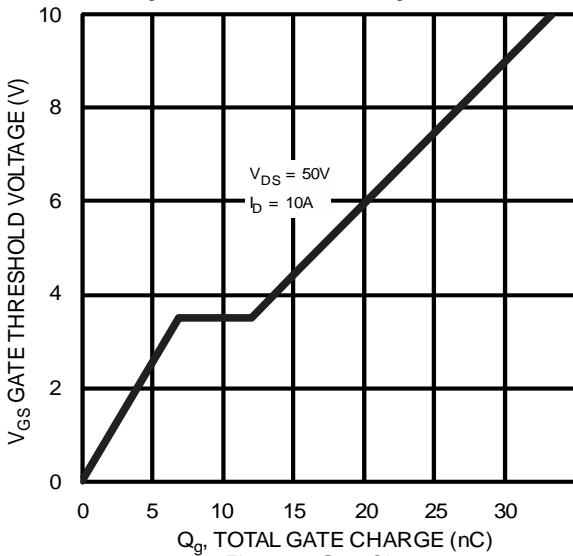

Figure 11 Gate Charge

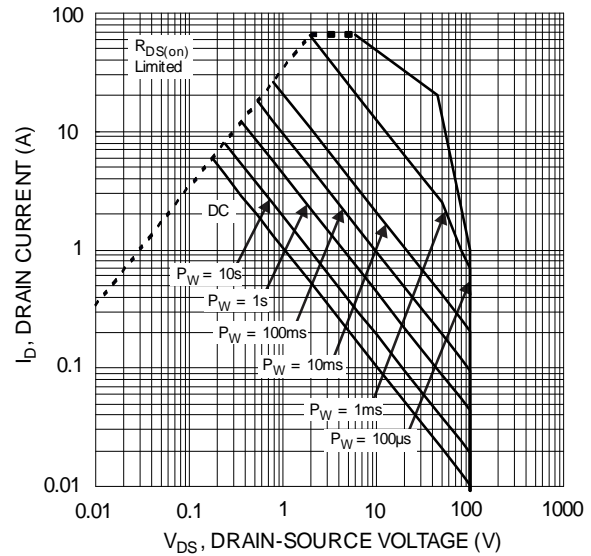

Figure 12 SOA, Safe Operation Area

HIGH VOLTAGE MOSFET (N-CHANNEL)

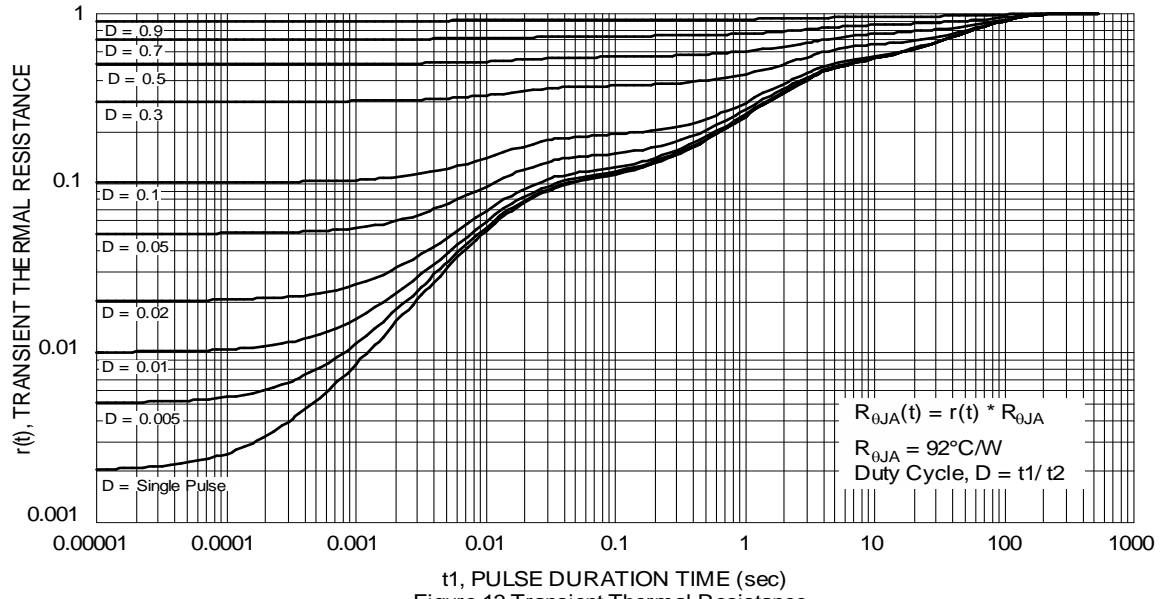
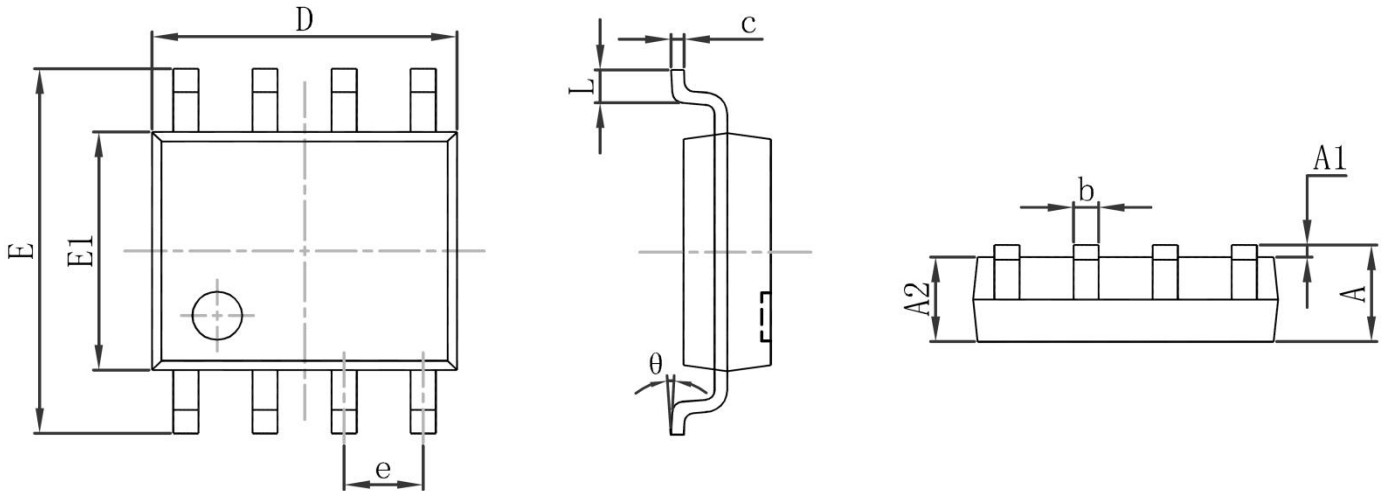

Figure 13 Transient Thermal Resistance

HIGH VOLTAGE MOSFET (N-CHANNEL)

SOP-8 Package Outline Dimensions



Symbol	Dimensions In Millimeters		Dimensions In Inches	
	Min.	Max.	Min.	Max.
A	1.350	1.750	0.053	0.069
A1	0.100	0.250	0.004	0.010
A2	1.350	1.550	0.053	0.061
b	0.330	0.510	0.013	0.020
c	0.170	0.250	0.007	0.010
D	4.800	5.000	0.189	0.197
e	1.270(BSC)		0.050 (BSC)	
E	5.800	6.200	0.228	0.244
E1	3.800	4.000	0.150	0.157
L	0.400	1.270	0.016	0.050
θ	0°	8°	0°	8°

SOP-8 Suggested Pad Layout

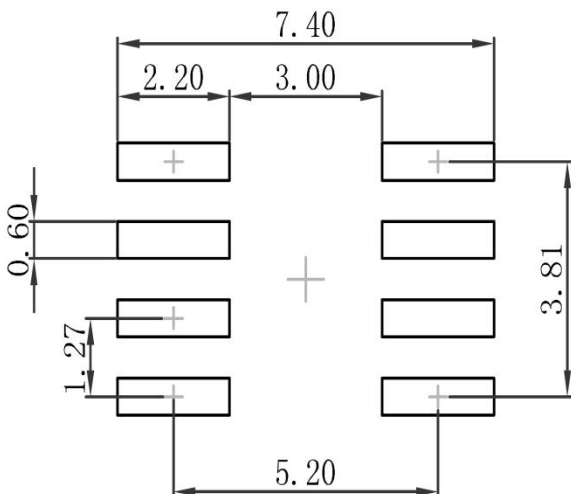

Note:

1. Controlling dimension: in millimeters
2. General tolerance: ±0.05mm
3. The pad layout is for reference purposes only

HIGH VOLTAGE MOSFET (N-CHANNEL)

SOP-8 Tape and Reel

SOP-8 Embossed Carrier Tape

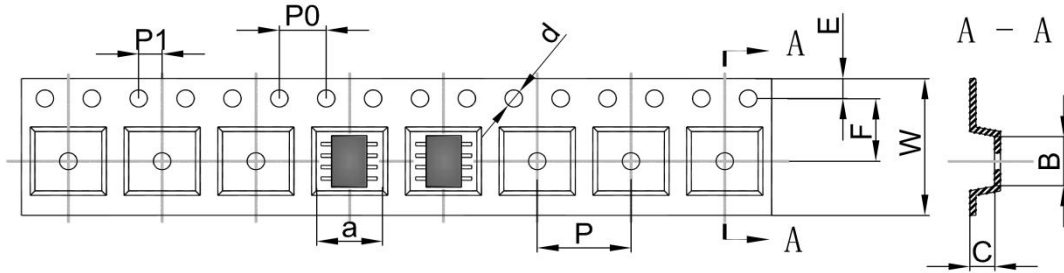

DIMENSIONS ARE IN MILLIMETER										
TYPE	A	B	C	d	E	F	P0	P	P1	W
SOP-8	6.40	5.40	2.10	Ø1.50	1.75	5.50	4.00	8.00	2.00	12.00
TOLERANCE	±0.1	±0.1	±0.1	±0.1	±0.1	±0.1	±0.1	±0.1	±0.1	±0.1

SOP-8 Tape Leader and Trailer

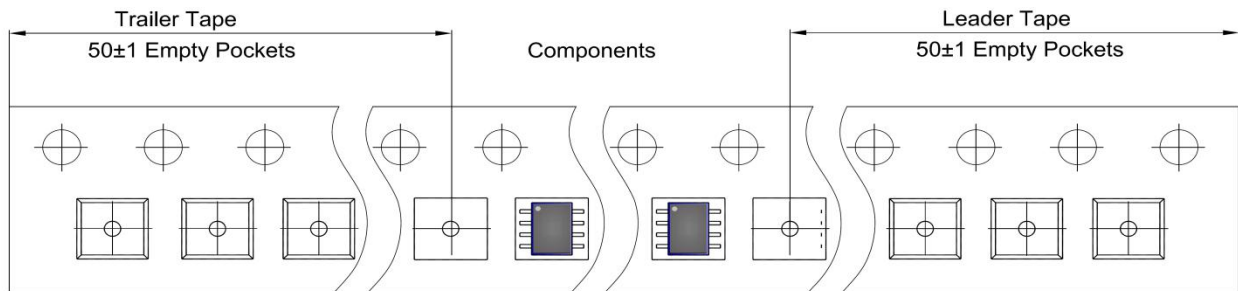

SOP-8 Reel

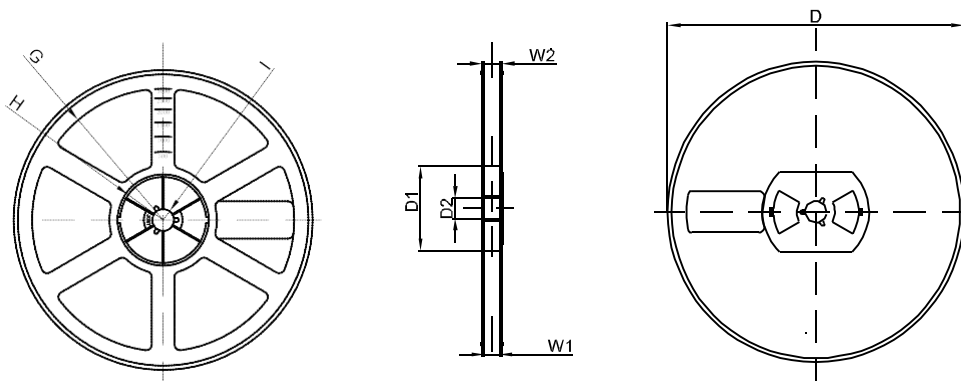

DIMENSIONS ARE IN MILLIMETER								
REEL OPTION	D	D1	D2	G	H	I	W1	W2
13" DIA	Ø330.00	100.00	13.00	R151.00	R56.00	R6.50	12.40	17.60
TOLERANCE	±2	±1	±1	±1	±1	±1	±1	±1