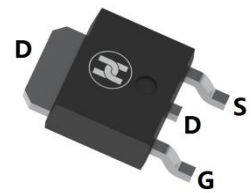
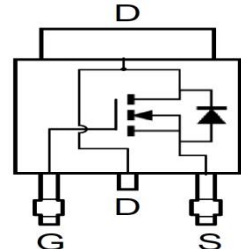

**N-CHANNEL HIGH VOLTAGE MOSFET**
**FEATURES**

- $V_{DS}=100V, R_{DS(ON)} \leq 80m\Omega @ V_{GS}=10V, I_D=18A$
- Low  $R_{DS(ON)}$  – ensures on state losses are minimized
- For Power Management Functions and DC-DC Converters Applications
- Surface Mount device

**TO-252**

**MECHANICAL DATA**

- Case: TO-252
- Case Material: Molded Plastic. UL flammability
- Classification Rating: 94V-0
- Moisture Sensitivity: Level 1 per J-STD-020
- Weight: 0.33 grams (approximate)

**MAXIMUM RATINGS ( $T_A = 25^\circ\text{C}$  unless otherwise noted)**

Parameter	Symbol	Value	Unit
Drain-source voltage	$V_{DS}$	100	V
Gate-source voltage	$V_{GS}$	$\pm 20$	V
Continuous drain current, $V_{GS} = 10V(1)$	$I_D$	$T_C = +25^\circ\text{C}$	18
		$T_C = +70^\circ\text{C}$	14
Pulsed drain current (380 $\mu\text{s}$ Pulse, Duty Cycle = 1%)	$I_{DM}$	16	A
Avalanche Current, $L = 1\text{mH}$	$I_{AS}$	8	A
Avalanche Energy, $L = 1\text{mH}$	$E_{AS}$	32.6	mJ
Power dissipation(1)	$P_D$	$T_C = +25^\circ\text{C}$	37
		$T_C = +70^\circ\text{C}$	24
Thermal resistance from Junction to ambient (1)	$R_{\theta JA}$	46	$^\circ\text{C}/\text{W}$
Thermal Resistance, Junction to Case (1)	$R_{\theta JC}$	3.3	$^\circ\text{C}/\text{W}$
Operating and Storage temperature	$T_J, T_{STG}$	-55 ~ +150	$^\circ\text{C}$

**ELECTRICAL CHARACTERISTICS ( $T_A = 25^\circ\text{C}$  unless otherwise specified)**

Parameter	Symbol	Min	Typ	Max	Unit	Conditions
Drain-Source breakdown voltage(2)	$V_{(BR)DSS}$	100			V	$V_{GS}=0V, I_D=250\mu\text{A}$
Zero gate voltage drain current(2)	$I_{DSS}$			1	$\mu\text{A}$	$V_{DS}=80V, V_{GS}=0V$
Gate-body leakage current(2)	$I_{GSS}$			$\pm 100$	nA	$V_{DS}=0V, V_{GS}=\pm 20V$
Gate-threshold voltage (2)	$V_{GS(th)}$	1.0	2.0	3.0	V	$V_{DS}=V_{GS}, I_D=250\mu\text{A}$
Drain-source on-resistance (2)	$R_{DS(ON)}$		65	80	$m\Omega$	$V_{GS}=10V, I_D=3.3A$
			70	100	$m\Omega$	$V_{GS}=6V, I_D=3A$
Diode forward voltage (2)	$V_{SD}$		0.77		V	$I_S=3.2A, V_{GS}=0V$
Input capacitance (3)	$C_{ISS}$		1172		pF	$V_{DS}=50V, V_{GS}=0V, f=1\text{MHz}$
Output capacitance(3)	$C_{OSS}$		40.8		pF	
Reverse transfer capacitance(3)	$C_{RSS}$		31.3		pF	
Gate Resistance(3)	$R_g$		1.6		$\Omega$	$V_{DS}=0V, V_{GS}=0V, f=1\text{MHz}$
Turn-on delay time(3)	$t_{d(on)}$		5.4		nS	$V_{DD}=50V, I_D=3.3A, R_g=6.0\Omega$
Turn-on rise time(3)	$t_r$		5.9		nS	
Turn-off delay time(3)	$t_{d(off)}$		20		nS	
Turn-off fall time(3)	$t_f$		7.3		nS	$V_{DS}=50V, V_{GS}=10V, I_D=3.3A$
Total Gate Charge(3)	$Q_g$		12.2		nC	
Total gate charge(3)	$Q_g$		25.2		nC	
Gate-source charge(3)	$Q_{gs}$		5.3		nC	$V_{DD}=50V, V_{GS}=10V, I_D=3.3A$
Gate-drain charge(3)	$Q_{gd}$		5.9		nC	
Body Diode Reverse Recovery Time(3)	$t_{rr}$		19.7		nS	
Body Diode Reverse Recovery Charge(3)	$Q_{rr}$		15.9		nC	$I_S=3.3A, di/dt=100A/\mu\text{s}$

Notes:1. Device mounted on FR-4 substrate PC board, 2oz copper, with 1inch square copper plate.

2. Short duration pulse test used to minimize self-heating effect.

3. Guaranteed by design. Not subject to production testing.

**N-CHANNEL HIGH VOLTAGE MOSFET**

**Typical Characteristics**

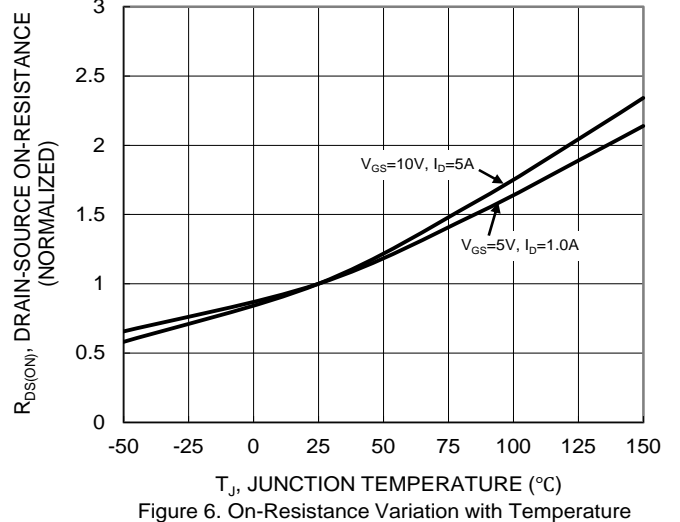
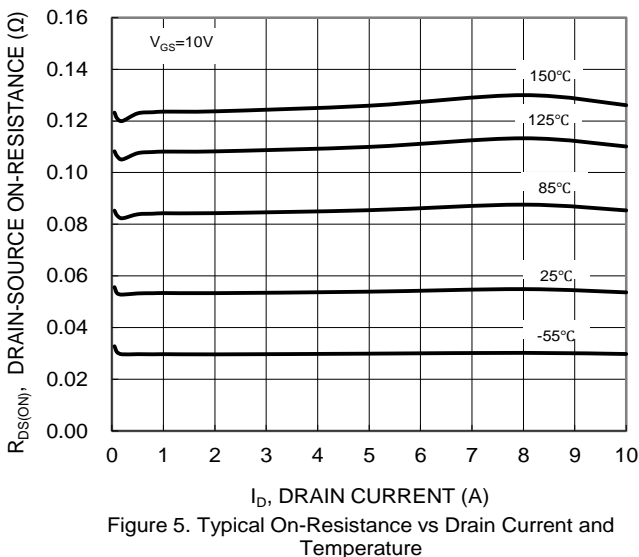
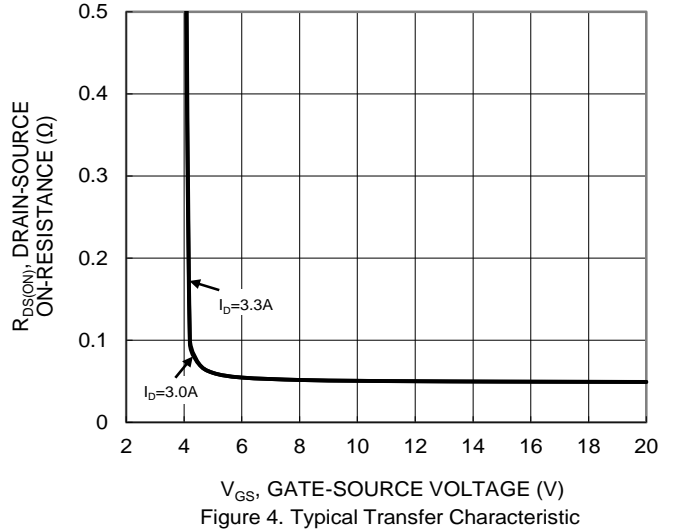
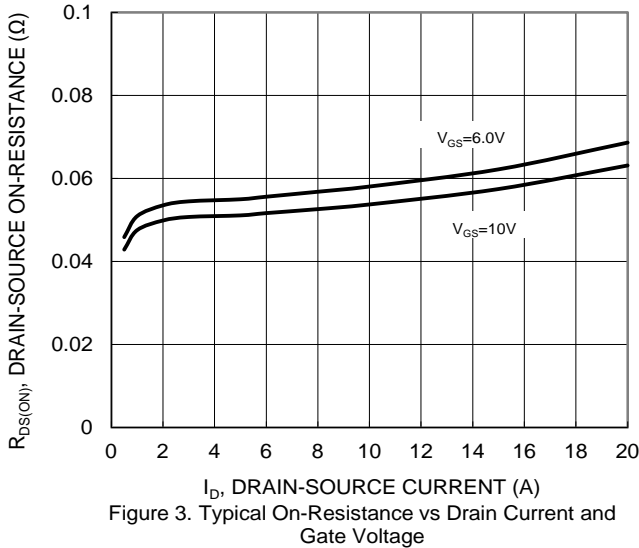
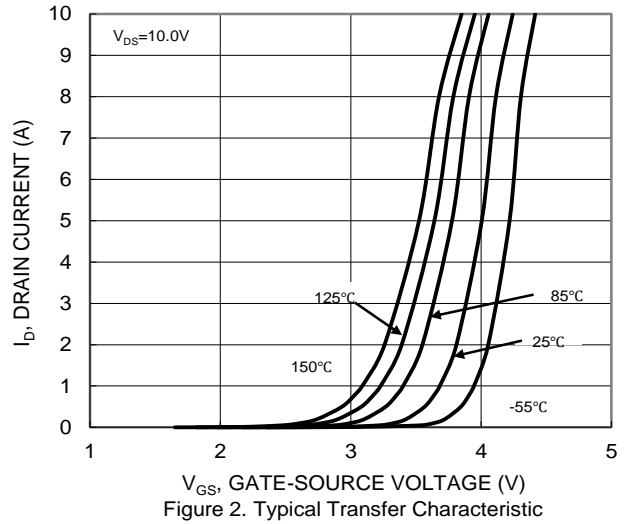
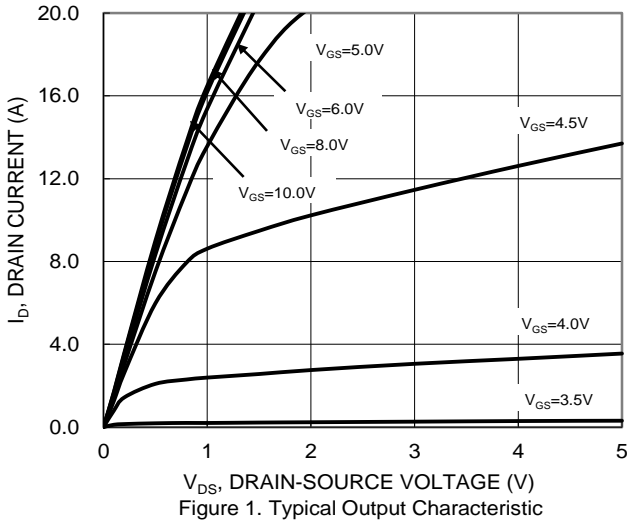

**N-CHANNEL HIGH VOLTAGE MOSFET**

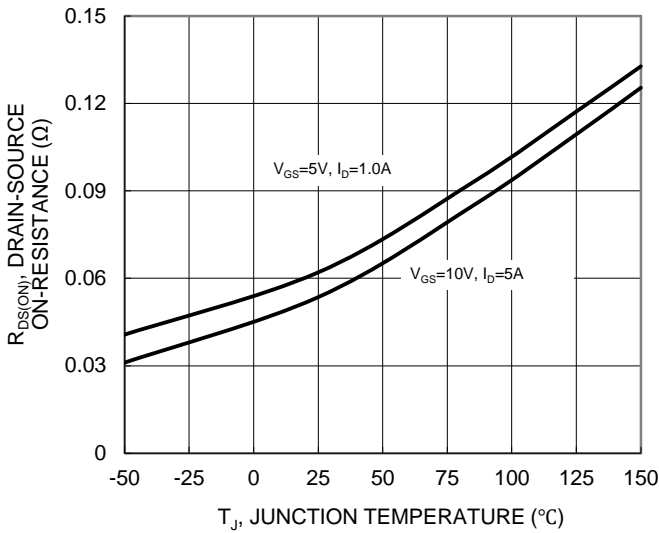

Figure 7. On-Resistance Variation with Temperature

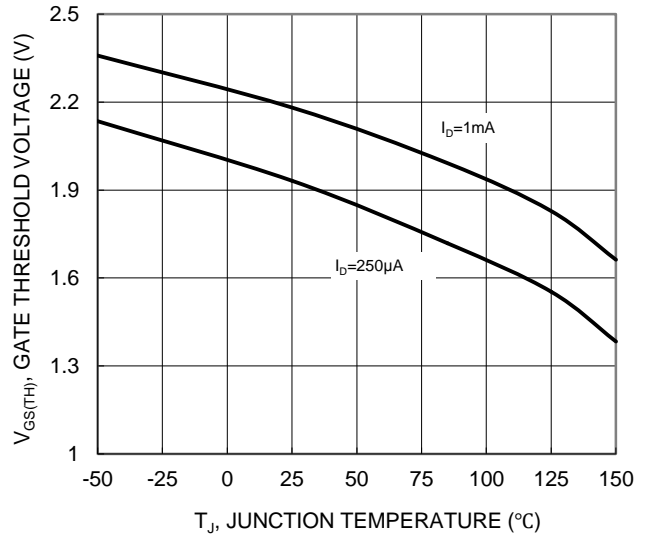

Figure 8. Gate Threshold Variation vs Temperature

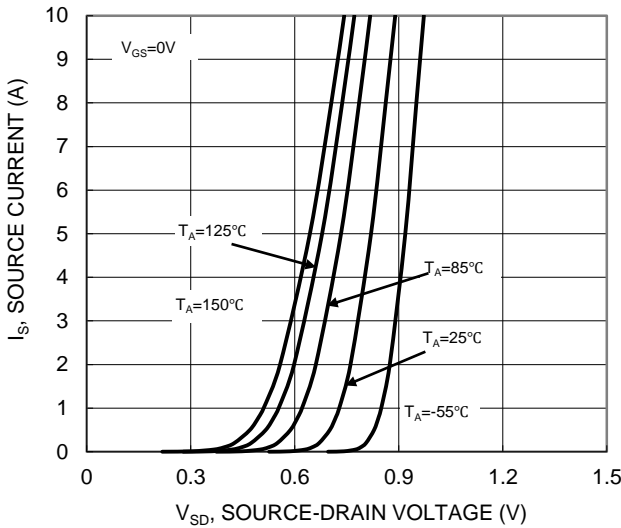

Figure 9. Diode Forward Voltage vs Current

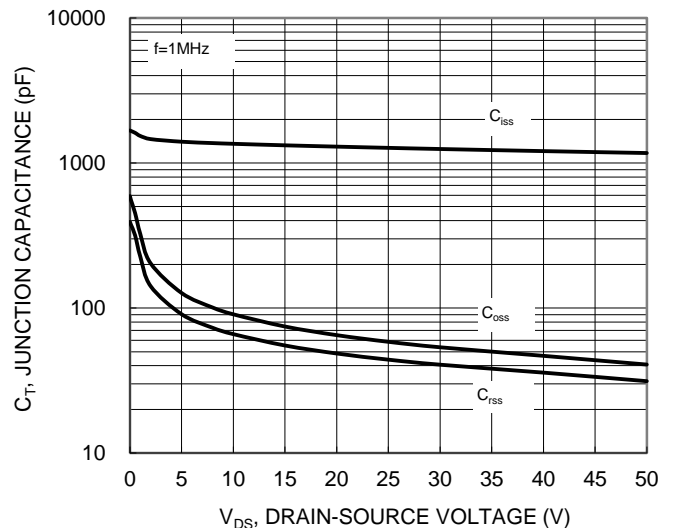

Figure 10. Typical Junction Capacitance

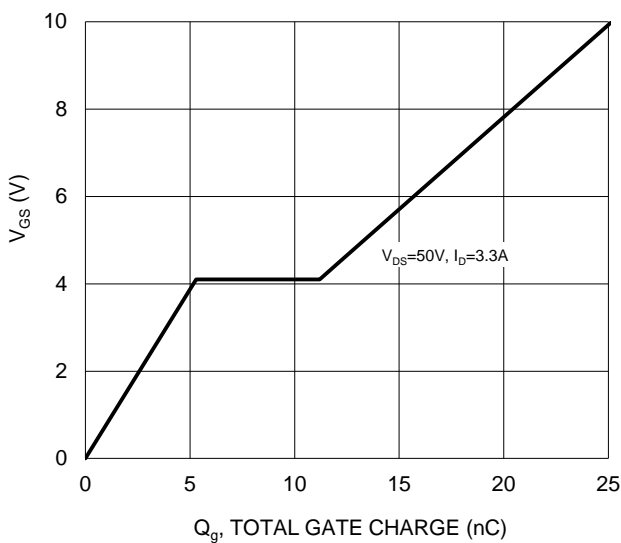

Figure 11. Gate Charge

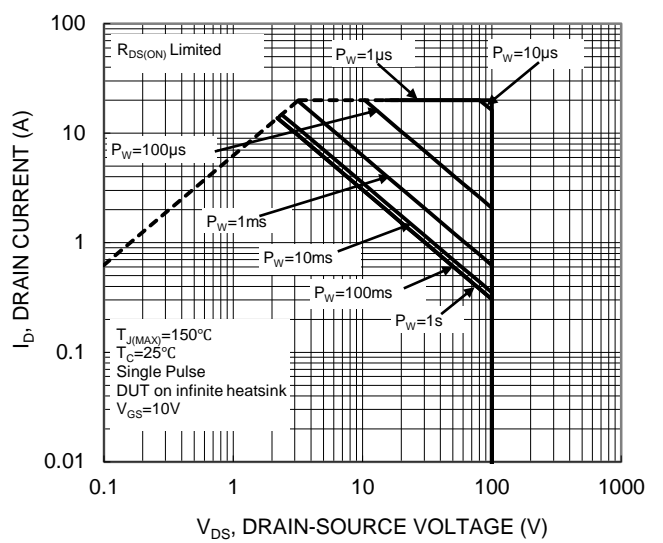

Figure 12. SOA, Safe Operation Area

N-CHANNEL HIGH VOLTAGE MOSFET

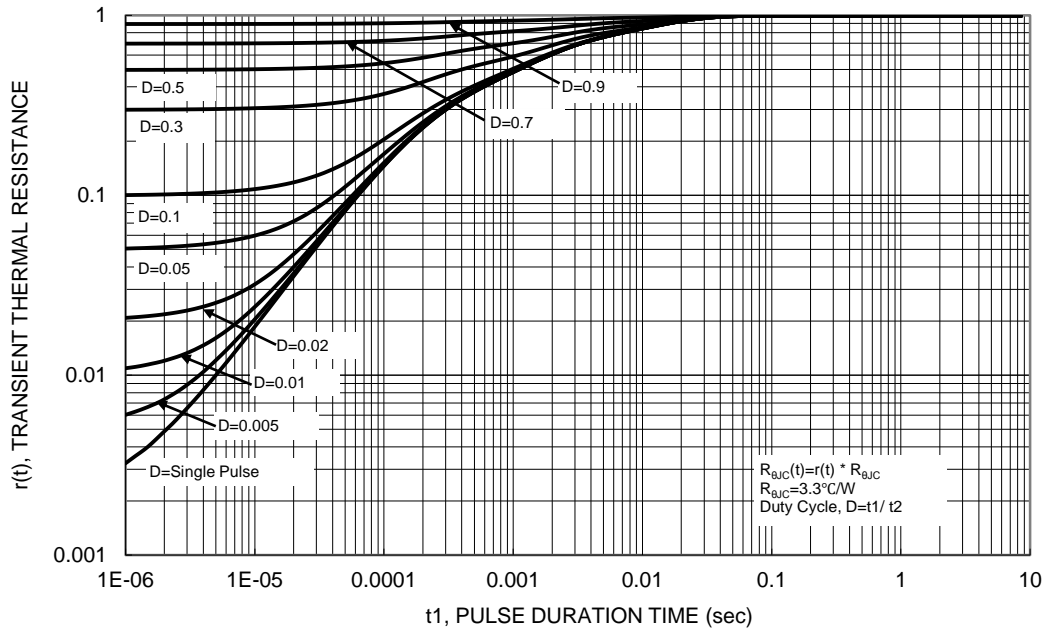
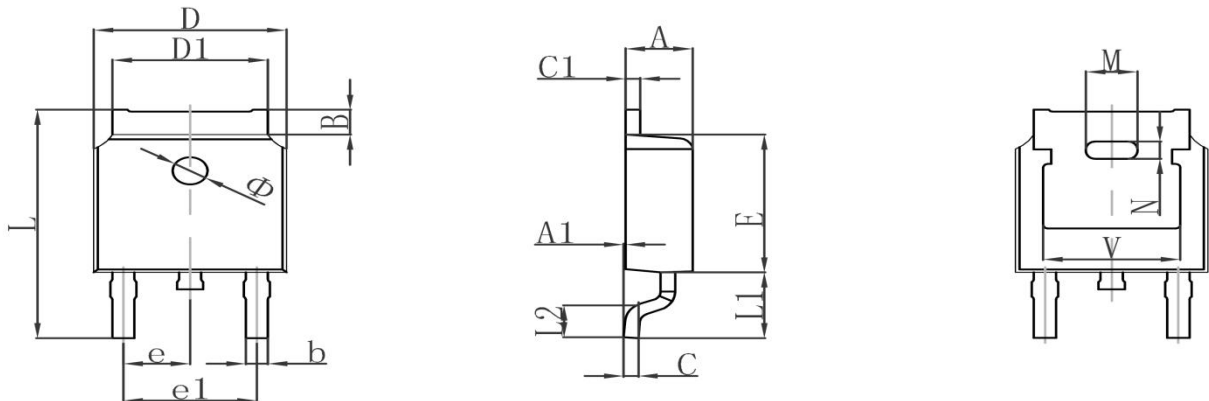
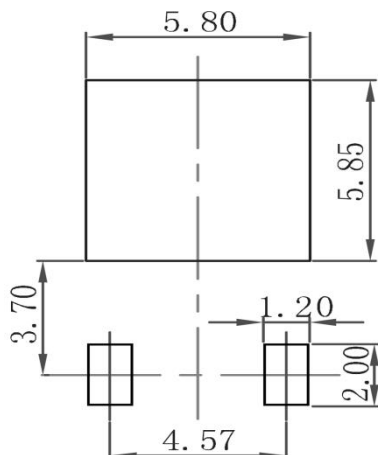

Figure 13. Transient Thermal Resistance

**N-CHANNEL HIGH VOLTAGE MOSFET**
**TO-252 Package Outline Dimensions**

Symbol	Dimensions In Millimeters		Dimensions In Inches	
	Min.	Max.	Min.	Max.
A	2.200	2.380	0.087	0.094
A1	0.000	0.100	0.000	0.004
B	0.800	1.400	0.031	0.055
b	0.710	0.810	0.028	0.032
c	0.460	0.560	0.018	0.022
c1	0.460	0.560	0.018	0.022
D	6.500	6.700	0.256	0.264
D1	5.130	5.460	0.202	0.215
E	6.000	6.200	0.236	0.244
e	2.286TYP		0.090TYP	
e1	4.327	4.727	0.170	0.186
M	1.778REF		0.070REF	
N	0.762REF		0.018REF	
L	9.800	10.400	0.386	0.409
L1	2.9REF		0.114REF	
L2	1.400	1.700	0.055	0.067
V	4.830REF		0.190REF	
Φ	1.100	1.300	0.043	0.051

**TO-252 Suggested Pad Layout**

**Note:**

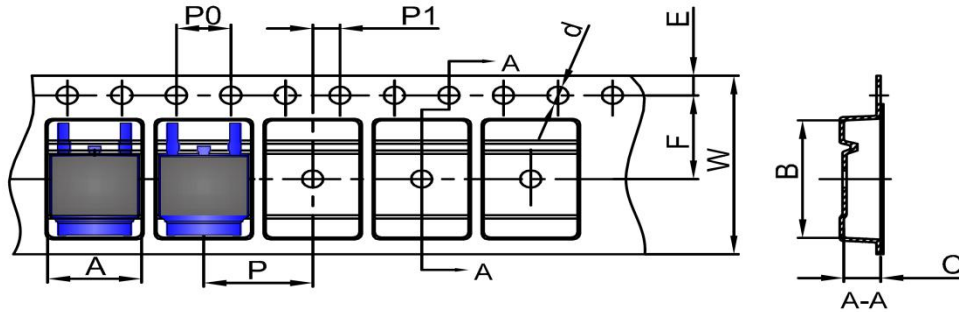
1. Controlling dimension: in millimeters
2. General tolerance:  $\pm 0.05\text{mm}$
3. The pad layout is for reference purposes only

**N-CHANNEL HIGH VOLTAGE MOSFET**
**TO-252 Tape and Reel**
**TO-252 Embossed Carrier Tape**

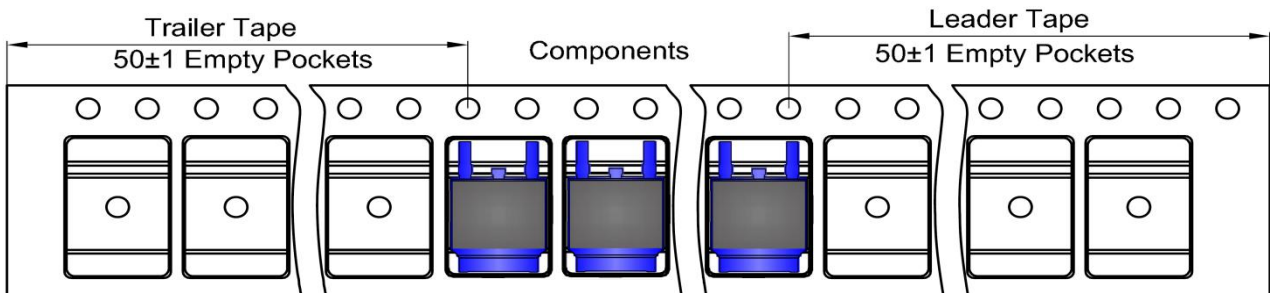
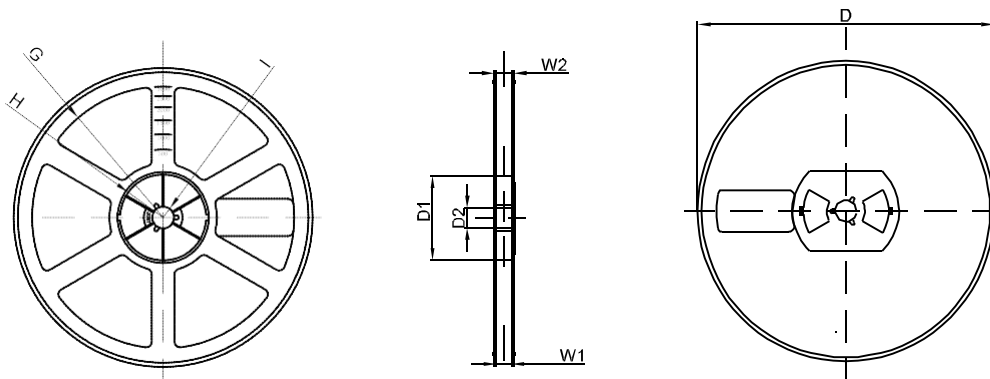
DIMENSIONS ARE IN MILLIMETER										
TYPE	A	B	C	d	E	F	P0	P	P1	W
TO-252	6.90	10.50	2.70	Ø1.55	1.75	7.50	4.00	8.00	2.00	16.00
TOLERANCE	±0.1	±0.1	±0.1	±0.1	±0.1	±0.1	±0.1	±0.1	±0.1	±0.1

**TO-252 Tape Leader and Trailer**

**TO-252 Reel**

DIMENSIONS ARE IN MILLIMETER								
REEL OPTION	D	D1	D2	G	H	I	W1	W2
13" DIA	Ø330.00	100.00	Φ21.00	R151.00	R56.00	R6.50	16.40	21.00
TOLERANCE	±2	±1	±1	±1	±1	±1	±1	±1