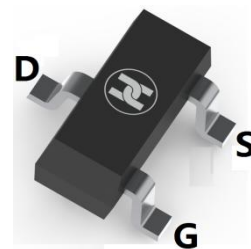
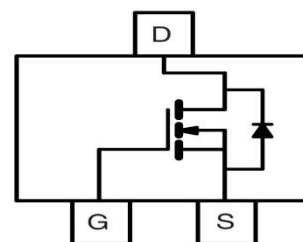

HIGH VOLTAGE MOSFET (N-CHANNEL)
FEATURES

- Low on-resistance: $V_{DS}=100V, R_{DS(ON)}=700m\Omega @ V_{GS}=10V, I_D=0.7A$
- Low Input Capacitance
- Fast Switching Speed
- Low Gate Threshold Voltage
- Surface Mount device

SOT-23

MECHANICAL DATA

- Case: SOT-23
- Case Material: Molded Plastic. UL flammability
- Classification Rating: 94V-0
- Moisture Sensitivity: Level 1 per J-STD-020
- Weight: 0.008 grams (approximate)

MAXIMUM RATINGS ($T_A = 25^\circ\text{C}$ unless otherwise noted)

Parameter	Symbol	Value	Unit
Drain-source voltage	V_{DS}	100	V
Gate-source voltage	V_{GS}	± 20	V
Continuous drain current	I_D	0.7	A
Pulsed drain current (10 μ s Pulse, Duty Cycle $\leq 1\%$)	I_{DM}	2.5	A
Maximum Body Diode Continuous Current	I_S	0.6	A
Power dissipation	P_D	0.5	W
Thermal resistance from Junction to ambient	$R_{\theta JA}$	303	$^\circ\text{C/W}$
Junction temperature	T_J	150	$^\circ\text{C}$
Storage temperature	T_{STG}	-55 ~ +150	$^\circ\text{C}$

ELECTRICAL CHARACTERISTICS ($T_A = 25^\circ\text{C}$ unless otherwise specified)

Parameter	Symbol	Min	Typ	Max	Unit	Conditions
STATIC CHARACTERISTICS						
Drain-Source breakdown voltage	$V_{(BR)DSS}$	100			V	$V_{GS}=0V, I_D=250\mu A$
Zero gate voltage drain current	I_{DSS}			1	μA	$V_{DS}=100V, V_{GS}=0V$
Gate-body leakage current	I_{GSS}			± 100	nA	$V_{DS}=0V, V_{GS}=\pm 20V$
Gate-threshold voltage (note 1)	$V_{GS(th)}$	2.0	2.7	4.0	V	$V_{DS}=V_{GS}, I_D=250\mu A$
Drain-source on-resistance (note 1)	$R_{DS(ON)}$		540	700	$m\Omega$	$V_{GS}=10V, I_D=1.5A$
			550	900	$m\Omega$	$V_{GS}=6.0V, I_D=1.0A$
Diode forward voltage (note 1)	V_{SD}		0.9	1.1	V	$I_S=1.5A, V_{GS}=0V$
DYNAMIC CHARACTERISTICS						
Input capacitance	C_{iss}		235		pF	$V_{DS}=50V, V_{GS}=0V, f=1MHz$
Output capacitance	C_{oss}		7		pF	
Reverse transfer capacitance	C_{rss}		5		pF	
Gate Resistance	R_g		1.9		Ω	$V_{DS}=0V, V_{GS}=0V, f=1MHz$
Total gate charge	Q_g		4.6		nC	$V_{DS}=50V, V_{GS}=10V, I_D=1.0A$
Gate-source charge	Q_{gs}		1.1		nC	
Gate-drain charge	Q_{gd}		1.6		nC	
Turn-on delay time	$t_{d(on)}$		2.5		nS	$V_{DS}=50V, V_{GS}=10V, R_{GEN}=6.0\Omega, I_D=1.0A$
Turn-on rise time	t_r		1.1		nS	
Turn-off delay time	$t_{d(off)}$		5.4		nS	
Turn-off fall time	t_f		1.0		nS	
Reverse Recovery Time	t_{rr}		22		nS	
Reverse Recovery Charge	Q_{rr}		15		nC	$I_F=1.1A, di/dt=100A/\mu S, V_R=100V$

Note: 1. Pulse test

HIGH VOLTAGE MOSFET (N-CHANNEL)

Typical Characteristics

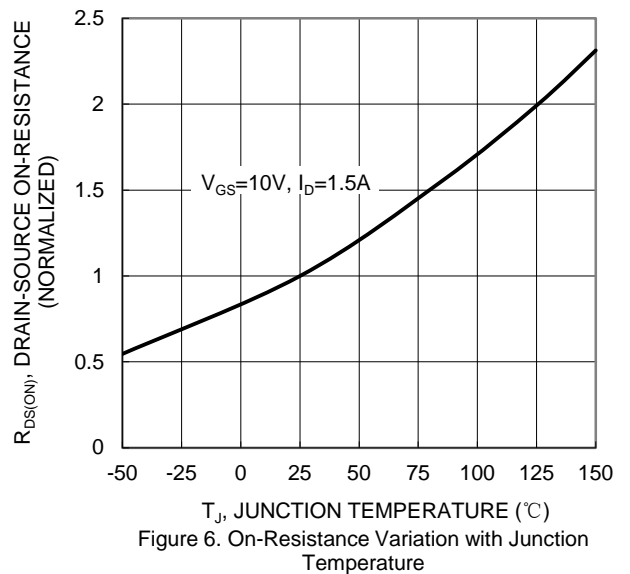
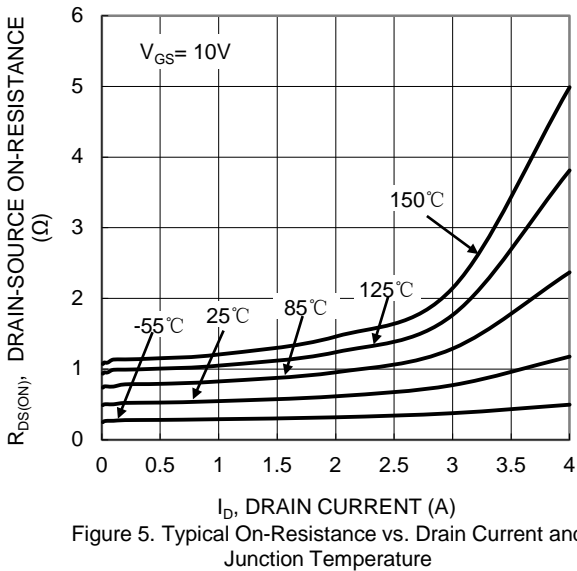
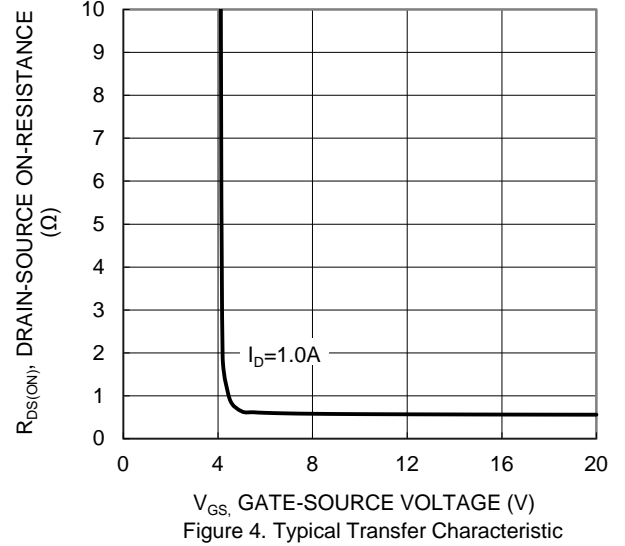
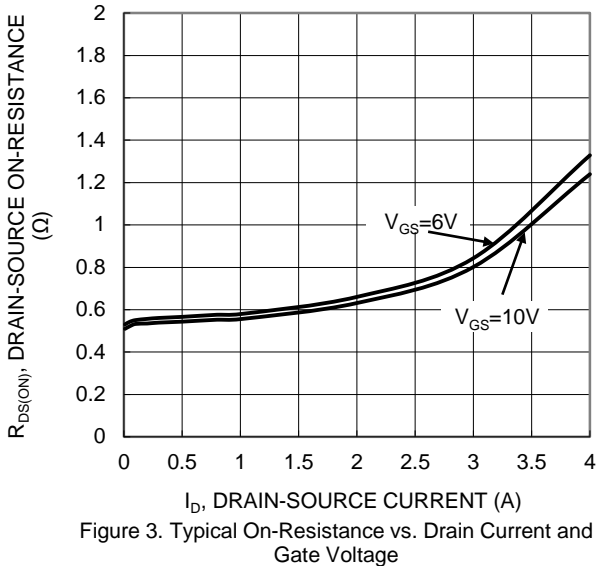
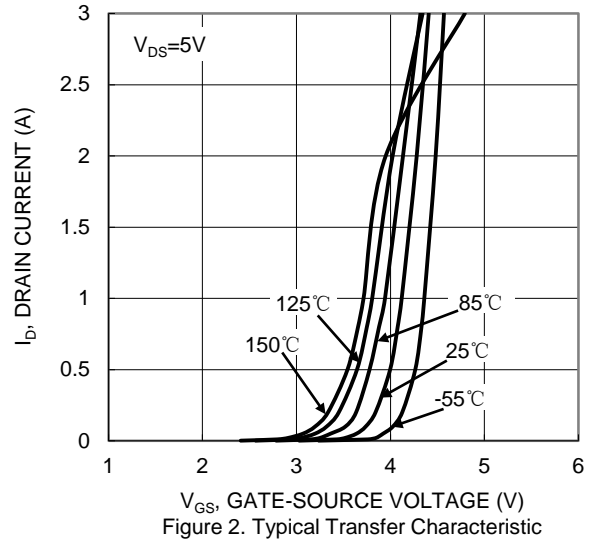
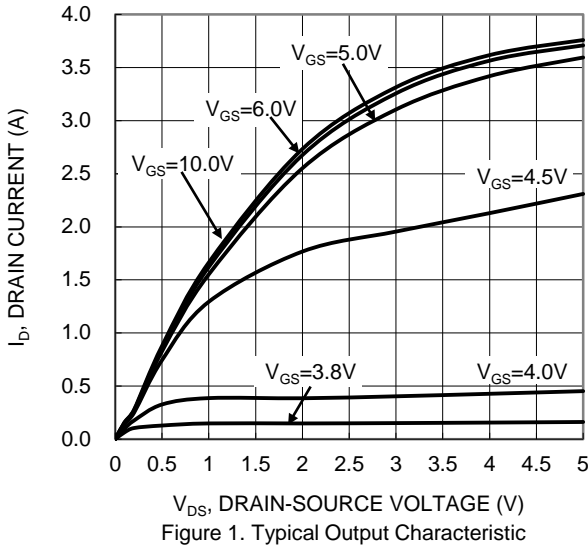

HIGH VOLTAGE MOSFET (N-CHANNEL)

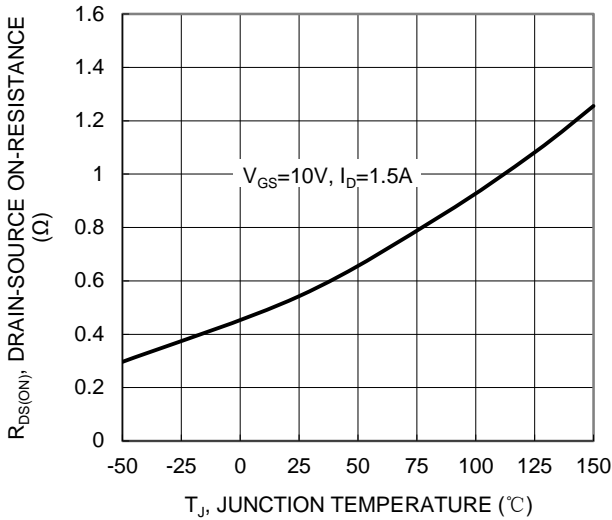

Figure 7. On-Resistance Variation with Junction Temperature

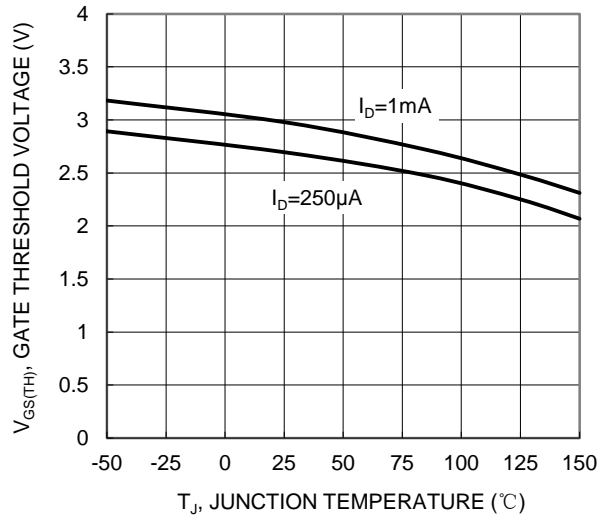

Figure 8. Gate Threshold Variation vs. Junction Temperature

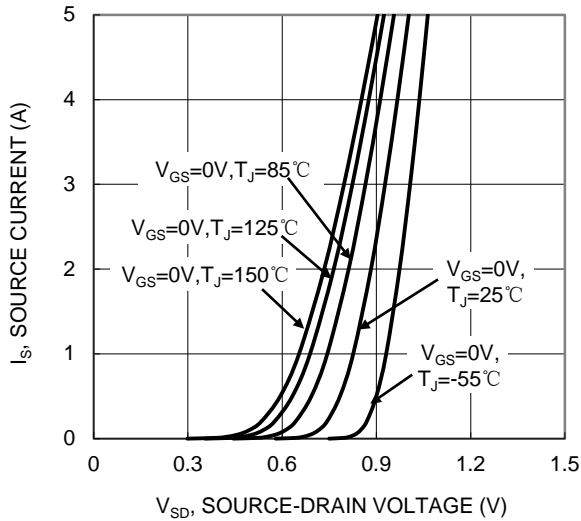

Figure 9. Diode Forward Voltage vs. Current

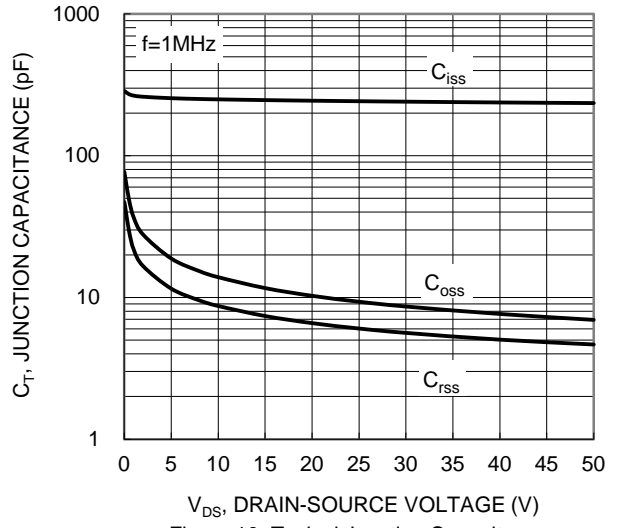

Figure 10. Typical Junction Capacitance

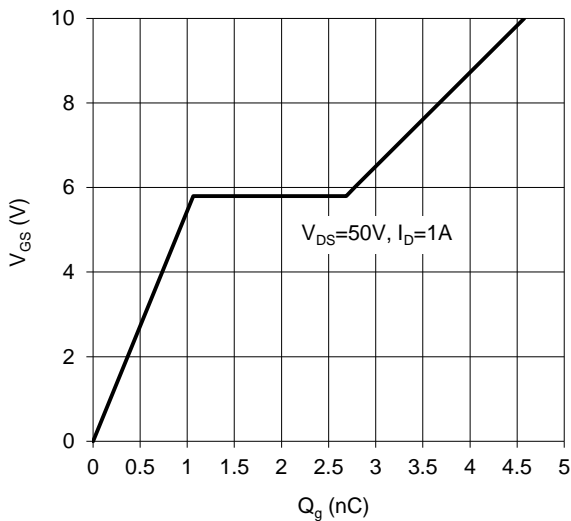

Figure 11. Gate Charge

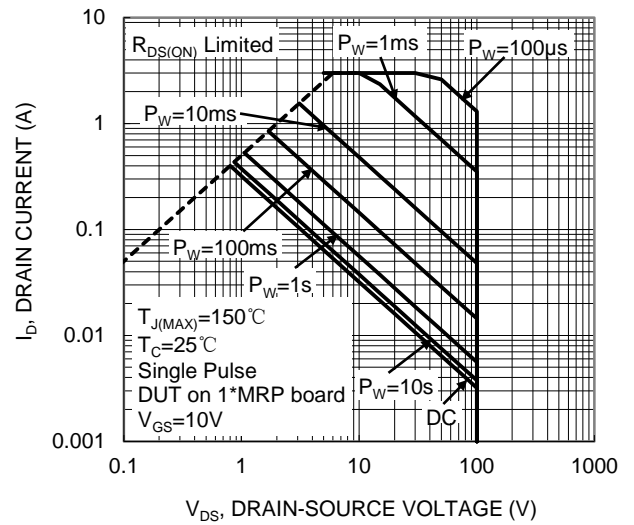

Figure 12. SOA, Safe Operation Area

HIGH VOLTAGE MOSFET (N-CHANNEL)

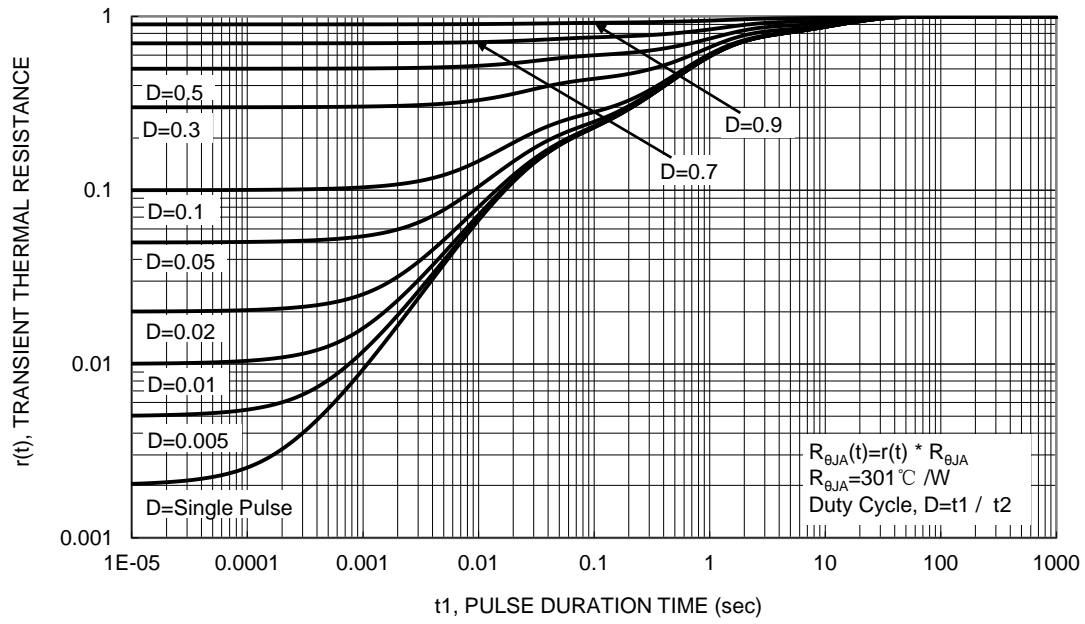
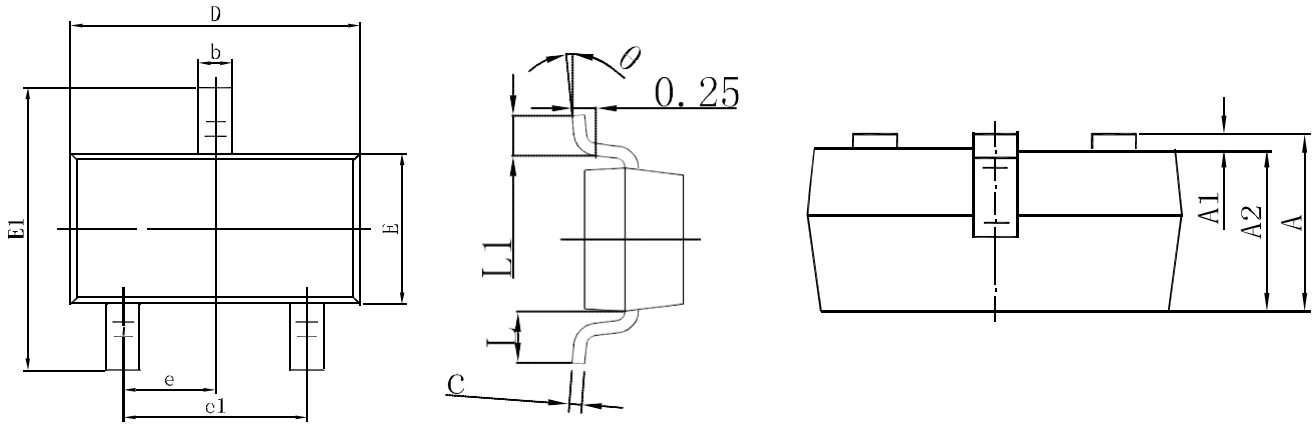
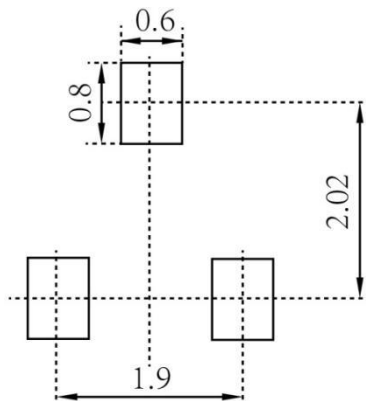

Figure 13. Transient Thermal Resistance

HIGH VOLTAGE MOSFET (N-CHANNEL)
SOT-23 Package Outline Dimensions

Symbol	Dimensions In Millimeters		Dimensions In Inches	
	Min.	Max.	Min.	Max.
A	0.900	1.150	0.035	0.045
A1	0.000	0.100	0.000	0.004
A2	0.900	1.050	0.035	0.041
b	0.300	0.500	0.012	0.020
c	0.080	0.150	0.003	0.006
D	2.800	3.000	0.110	0.118
E	1.200	1.400	0.047	0.055
E1	2.250	2.550	0.089	0.100
e	0.950 TYP		0.037 TYP	
e1	1.800	2.000	0.071	0.079
L	0.550 REF		0.022 REF	
L1	0.300	0.500	0.012	0.020
θ	0°	8°	0°	8°

SOT-23 Suggested Pad Layout

Note:

1. Controlling dimension: in millimeters
2. General tolerance: $\pm 0.05\text{mm}$
3. The pad layout is for reference purposes only

HIGH VOLTAGE MOSFET (N-CHANNEL)

SOT-23 Tape and Reel

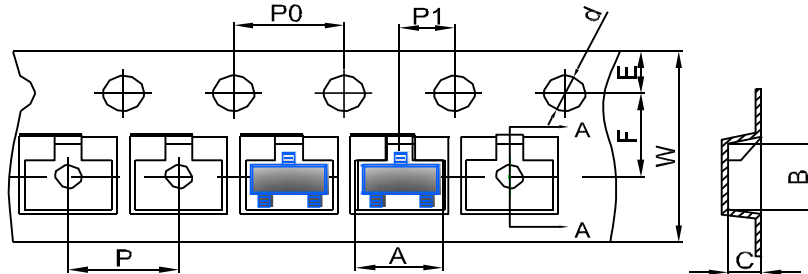
SOT-23 Embossed Carrier Tape



DIMENSIONS ARE IN MILLIMETER										
TYPE	A	B	C	d	E	F	P0	P	P1	W
SOT-23	3.15	2.77	1.22	Ø1.50	1.75	3.50	4.00	4.00	2.00	8.00
TOLERANCE	±0.1	±0.1	±0.1	±0.1	±0.1	±0.1	±0.1	±0.1	±0.1	±0.1

SOT-23 Tape Leader and Trailer

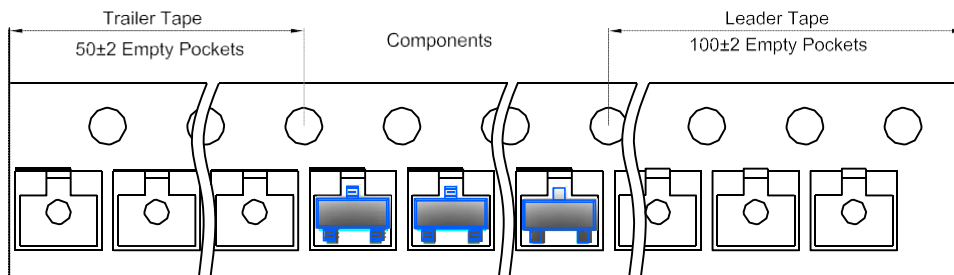

SOT-23 Reel

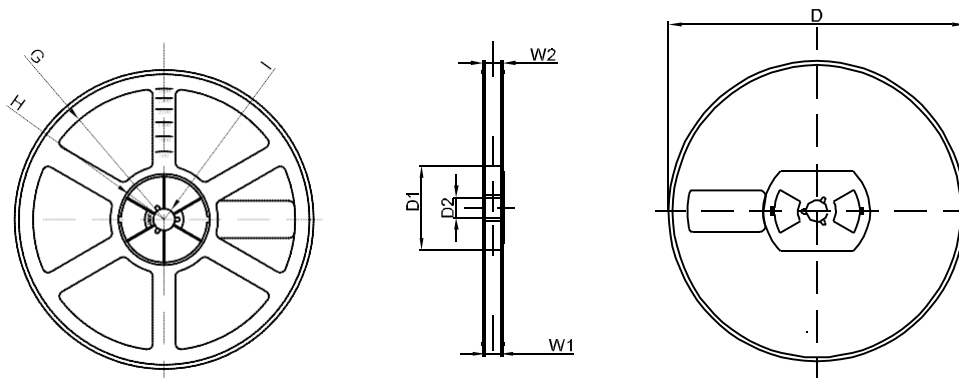

DIMENSIONS ARE IN MILLIMETER								
REEL OPTION	D	D1	D2	G	H	I	W1	W2
7" DIA	Ø178	54.40	13.00	R78	R25.60	R6.50	9.50	12.30
TOLERANCE	±2	±1	±1	±1	±1	±1	±1	±1