

## DH120 Series

120W Single Output LED Driver



### ■ Features

- Constant voltage and current output
- Universal AC input 100~305VAC
- Built-in active PFC function
- High efficiency
- Output protections: Short circuit/Over voltage/Over load
- Fixed derating-cutoff type temperature protection
- Cooling by free air convection
- Digital, analog or DALI control dimming function
- Suitable for inside of the outdoor LED luminaries
- IP65 with Vo/Io adjusting screws, IP67 without Vo/Io adjusting screws
- Compliance to worldwide safety regulations for lighting
- Suitable for dry/damp/wet locations



IP65/67



### ■ General functions

Output Power	120W	Input Frequency	50/60Hz
Input Voltage Range	100~305Vac	Operating Temperature	-40°C~+60°C
Storage Temperature	-45°C~+85°C	Safety & EMC	UL8750, IEC61347, EN55015
Turn-on Delay Time	3.0S max.	Inrush Current	50A at 230Vac, Cold start
Over Temp Protection	Fixed derating-cutoff type temperature protection	Waterproof	IP65/IP67

## ■ Detailed Specification

TABLE 1:

Model		DH120-069S175X-YY	DH120-058S210X-YY	DH120-054S222X-YY	DH120-048S250X-YY	DH120-042S280X-YY
Output	DC Voltage	69Vdc	58Vdc	54Vdc	48Vdc	42Vdc
	Constant Current Operation Voltage <small>note.5</small>	41~69Vdc	35~58Vdc	33~54Vdc	29~48Vdc	26~42Vdc
	Rated DC Current	1750 mA	2100 mA	2220 mA	2500 mA	2800 mA
	Current Range	0~1750mA	0~2100mA	0~2220mA	0~2500mA	0~2800mA
	Dimming Current Range	10~100% rated output current (≥50% rated output voltage)				
	Ripple and Noise	1Vp-p	1Vp-p	200mVp-p	200mVp-p	200mVp-p
	Voltage ADJ. Range <small>note.3</small>	62~72Vdc	52~61Vdc	49~57Vdc	43~50Vdc	38~44Vdc
	Current ADJ. Range <small>note.3</small>	1050~1750mA	1260~2100mA	1332~2220mA	1500~2500mA	1680~2800mA
	Voltage Tolerance	±1%	±1%	±1%	±1%	±1%
	Voltage Line Regulation	±0.5%	±0.5%	±0.5%	±0.5%	±0.5%
	Voltage Load Regulation	±0.5%	±0.5%	±0.5%	±0.5%	±0.5%
Input	Efficiency	93.5%	93.5%	93.5%	93.5%	93%
	Power Factor	0.97/230Vac	0.97/230Vac	0.97/230Vac	0.97/230Vac	0.97/230Vac
	AC Current	1.5A/100Vac, 0.7A/230Vac				
	Leakage Current	<0.75mA/230Vac; <0.5mA/120Vac				
Output Protection	Over Current	Constant current limiting				
	Short Circuit	Non-dimmer type: recover automatically at hiccup; Dimmer type: Short-circuit power ≤10W.				
	Over Voltage	Shut down at 140% Vo and latch off o/p voltage, re-power on to recover				
Environmental	Operating Humidity	20~95% RH, non-condensing				
	Storage Humidity	10~95% RH				
	Temperature Coefficient	±0.03%/°C (0~50°C)				
	Vibration	10~300Hz, 1G, Period for 60min, each along X、Y、Z axes.				
Safety & EMC	Withstand Voltage	I/P-OP: 3.75KVac; IP-FG: 1.56KVac/2.00KVac (remove discharge tube); O/P-FG: 2.00KVac				
	Isolation Resistance	IP-OP, IP-FG, O/P-FG: 100M Ohms/500Vdc/25°C/70% RH				
	EMC Interference	Compliance to EN55015, EN55022 (CISPR22) Class B				
	EMC Emission	Compliance to EN61000-3-2 Class C (≥50%load); EN61000-3-3				
	EMC Immunity	Compliance to EN61000-4-2, 3, 4, 5, 6, 8, 11; ENV50204, EN61547, EN55024				
Others	Authentication	UL / CE/RoHS/REACH				
	MTBF	211k Hrs at full load and 30°C ambient conditions per MIL-HDBK-217F				
	Input Over-voltage	Can survive input over-voltage stress of 320Vac for 48 hours				
	Dimensions (mm)	215×68×41.3				
	Max. Case Temp.	Tc max=80°C				
	Net Weight	1.07Kg/pcs				
Note	1. All parameters NOT specially mentioned are measured at 230Vac input, rated load and 25 °C of ambient temperature.					
	2. Ripple & noise are measured: at 20MHz of bandwidth by using a 12" twisted pair-wire terminated with a 0.1μf & 47μf parallel capacitor.					
	3. Output voltage and current can be adjusted by internal potentiometer ("A" type only).					
	4. Tolerance: includes set up tolerance, voltage line regulation and voltage load regulation.					
	5. Constant current operation region is within 60% ~100% rated output voltage. This is the suitable operation region for LED related applications, but please reconfirm special electrical requirements for some specific system design.					
	6. Derating may be needed under low input voltages. Please check the Static Characteristics for more details.					
	7. Safety and EMC design refer to EN60598-1, subject 8750 (UL), CNS15233, GB7000.1, FCC part18.					
	8. Length of set up time is measured at cold first start. Turning ON/OFF the power supply may lead to increase of the set up time.					
	9. The power supply is considered as a component that will be operated in combination with final equipment. Since EMC performance will be affected by the complete installation, the final equipment manufacturers must re-qualify EMC Directive on the complete installation again.					

**TABLE 2:**

Model		DH120-036S350X-YY	DH120-029S420X-YY	DH120-024S500X-YY	DH120-020S600X-YY	DH120-015S800X-YY
Output	DC Voltage	36Vdc	29Vdc	24Vdc	20Vdc	15Vdc
	Constant Current Operation Voltage <small>note.5</small>	22~36Vdc	17~29Vdc	15~24Vdc	12~20Vdc	9~15Vdc
	Rated DC Current	3500 mA	4200 mA	5000mA	6000mA	8000mA
	Current Range	0~3500mA	0~4200mA	0~5000mA	0~6000mA	0~8000mA
	Dimming Current Range	10~100% rated output current (≥50% rated output voltage)				
	Ripple and Noise	200mVp-p	200mVp-p	150mVp-p	150mVp-p	150mVp-p
	Voltage ADJ. Range <small>note.3</small>	32~38Vdc	26~30Vdc	22~25Vdc	18~21Vdc	14~16Vdc
	Current ADJ. Range <small>note.3</small>	2100~3500mA	2520~4200mA	3000~5000mA	3600~6000mA	4800~8000mA
	Voltage Tolerance	±1%	±1%	±1%	±1%	±1%
	Voltage Line Regulation	±0.5%	±0.5%	±0.5%	±0.5%	±0.5%
	Voltage Load Regulation	±0.5%	±0.5%	±0.5%	±0.5%	±0.5%
Input	Efficiency	93.0%	93.0%	93.0%	93.0%	92.0%
	Power Factor	0.97/230Vac	0.97/230Vac	0.97/230Vac	0.97/230Vac	0.97/230Vac
	AC Current	1.5A/100Vac, 0.7A/230Vac				
	Leakage Current	<0.75mA/230Vac; <0.5mA/120Vac				
Output Protection	Over Current	Constant current limiting				
	Short Circuit	Non-dimmer type: recover automatically at hiccup; Dimmer type: Short-circuit power ≤10W.				
	Over Voltage	Shut down at 140% Vo and latch off o/p voltage, re-power on to recover				
Environmental	Operating Humidity	20~95% RH, non-condensing				
	Storage Humidity	10~95% RH				
	Temperature Coefficient	±0.03%/°C (0~50°C)				
	Vibration	10~300Hz, 1G, Period for 60min, each along X、Y、Z axes.				
Safety & EMC	Withstand Voltage	I/P-OP: 3.75KVac; IP-FG: 1.56KVac/2.00KVac (remove discharge tube); O/P-FG: 2.00KVac				
	Isolation Resistance	IP-OP, IP-FG, O/P-FG: 100M Ohms/500Vdc/25°C/70% RH				
	EMC Interference	Compliance to EN55015, EN55022 (CISPR22) Class B				
	EMC Emission	Compliance to EN61000-3-2 Class C (≥50% load); EN61000-3-3				
	EMC Immunity	Compliance to EN61000-4-2, 3, 4, 5, 6, 8, 11; ENV50204, EN61547, EN55024				
Others	Authentication	UL / CE/RoHS/REACH				
	MTBF	211k Hrs at full load and 30°C ambient conditions per MIL-HDBK-217F				
	Input Over-voltage	Can survive input over-voltage stress of 320Vac for 48 hours				
	Dimensions (mm)	215×68×41.3				
	Max. Case Temp.	Tc max=80°C				
	Net Weight	1.07Kg/pcs				
Note	1. All parameters NOT specially mentioned are measured at 230Vac input, rated load and 25°C of ambient temperature.					
	2. Ripple & noise are measured: at 20MHz of bandwidth by using a 12" twisted pair-wire terminated with a 0.1µf & 47µf parallel capacitor.					
	3. Output voltage and current can be adjusted by internal potentiometer ("A" type only).					
	4. Tolerance: includes set up tolerance, voltage line regulation and voltage load regulation.					
	5. Constant current operation region is within 60% ~100% rated output voltage. This is the suitable operation region for LED related applications, but please reconfirm special electrical requirements for some specific system design.					
	6. Derating may be needed under low input voltages. Please check the Static Characteristics for more details.					
	7. Safety and EMC design refer to EN60598-1, subject 8750 (UL), CNS15233, GB7000.1, FCC part18.					
	8. Length of set up time is measured at cold first start. Turning ON/OFF the power supply may lead to increase of the set up time.					
	9. The power supply is considered as a component that will be operated in combination with final equipment. Since EMC performance will be affected by the complete installation, the final equipment manufacturers must re-qualify EMC Directive on the complete installation again.					

TABLE 3:

Model		DH120-012S1000X-YY	DH120-343S035X-YY	DH120-267S045X-YY	DH120-172S070X-YY	DH120-110S110X-YY
Output	DC Voltage	12Vdc	343Vdc	267Vdc	172Vdc	110Vdc
	Constant Current Operation Voltage <small>note.5</small>	8~12Vdc	206~343Vdc	160~267Vdc	103~172Vdc	66~110Vdc
	Rated DC Current	10000mA	350 mA	450 mA	700 mA	1100 mA
	Current Range	0~10000mA	0~350mA	0~450mA	0~700 mA	0~1100mA
	Dimming Current Range	10~100% rated output current ( $\geq 50\%$ rated output voltage)				
	Ripple and Noise	150mVp-p	1Vp-p	1Vp-p	1Vp-p	1Vp-p
	Voltage ADJ. Range <small>note.3</small>	11~13Vdc	309~360Vdc	240~280Vdc	155~181Vdc	99~116Vdc
	Current ADJ. Range <small>note.3</small>	6000~10000mA	210~350mA	270~450mA	420~700 mA	660~1100mA
	Voltage Tolerance	$\pm 1\%$	$\pm 1\%$	$\pm 1\%$	$\pm 1\%$	$\pm 1\%$
	Voltage Line Regulation	$\pm 0.5\%$	$\pm 0.5\%$	$\pm 0.5\%$	$\pm 0.5\%$	$\pm 0.5\%$
Voltage Load Regulation	$\pm 0.5\%$	$\pm 0.5\%$	$\pm 0.5\%$	$\pm 0.5\%$	$\pm 0.5\%$	
Input	Efficiency	92.0%	93%	93%	93%	93.5%
	Power Factor	0.97/230Vac	0.97/230Vac	0.97/230Vac	0.97/230Vac	0.97/230Vac
	AC Current	1.5A/100Vac, 0.7A/230Vac				
	Leakage Current	<0.75mA/230Vac; <0.5mA/120Vac				
Output Protection	Over Current	Constant current limiting				
	Short Circuit	Non-dimmer type: recover automatically at hiccup; Dimmer type: Short-circuit power $\leq 10W$ .				
	Over Voltage	Shut down at 140% $V_o$ and latch off o/p voltage, re-power on to recover				
Environmental	Operating Humidity	20~95% RH, non-condensing				
	Storage Humidity	10~95% RH				
	Temperature Coefficient	$\pm 0.03\%/^{\circ}C$ (0~50 $^{\circ}C$ )				
	Vibration	10~300Hz, 1G, Period for 60min, each along X、Y、Z axes.				
Safety & EMC	Withstand Voltage	I/P-OP: 3.75KVac; IP-FG: 1.56KVac/2.00KVac (remove discharge tube); O/P-FG: 2.00KVac				
	Isolation Resistance	IP-OP, IP-FG, O/P-FG: 100M Ohms/500Vdc/25 $^{\circ}C$ /70% RH				
	EMC Interference	Compliance to EN55015, EN55022 (CISPR22) Class B				
	EMC Emission	Compliance to EN61000-3-2 Class C ( $\geq 50\%$ load); EN61000-3-3				
	EMC Immunity	Compliance to EN61000-4-2, 3, 4, 5, 6, 8, 11; ENV50204, EN61547, EN55024				
Others	Authentication	UL/ CE/RoHS/REACH	CE/RoHS/REACH			
	MTBF	211k Hrs at full load and 30 $^{\circ}C$ ambient conditions per MIL-HDBK-217F				
	Input Over-voltage	Can survive input over-voltage stress of 320Vac for 48 hours				
	Dimensions (mm)	215x68x41.3				
	Max. Case Temp.	$T_c \text{ max} = 80^{\circ}C$				
	Net Weight	1.07Kg/pcs				
Note	1. All parameters NOT specially mentioned are measured at 230Vac input, rated load and 25 $^{\circ}C$ of ambient temperature.					
	2. Ripple & noise are measured: at 20MHz of bandwidth by using a 12" twisted pair-wire terminated with a 0.1 $\mu$ f & 47 $\mu$ f parallel capacitor.					
	3. Output voltage and current can be adjusted by internal potentiometer ("A" type only).					
	4. Tolerance: includes set up tolerance, voltage line regulation and voltage load regulation.					
	5. Constant current operation region is within 60% ~100% rated output voltage. This is the suitable operation region for LED related applications, but please reconfirm special electrical requirements for some specific system design.					
	6. Derating may be needed under low input voltages. Please check the Static Characteristics for more details.					
	7. Safety and EMC design refer to EN60598-1, subject 8750 (UL), CNS15233, GB7000.1, FCC part18.					
	8. Length of set up time is measured at cold first start. Turning ON/OFF the power supply may lead to increase of the set up time.					
	9. The power supply is considered as a component that will be operated in combination with final equipment. Since EMC performance will be affected by the complete installation, the final equipment manufacturers must re-qualify EMC Directive on the complete installation again.					

TABLE 4:

Model		DH120-086S140X-YY	DH120-081S148X-YY	DH120-038S315X-YY		
Output	DC Voltage	86Vdc	81Vdc	38Vdc		
	Constant Current Operation Voltage <small>note.5</small>	52~86Vdc	49~81Vdc	23~38Vdc		
	Rated DC Current	1400 mA	1480 mA	3150 mA		
	Current Range	0~1400mA	0~1480mA	0~3150mA		
	Dimming Current Range	10~100% rated output current (≥50% rated output voltage)				
	Ripple and Noise	1Vp-p	1Vp-p	200mVp-p		
	Voltage ADJ. Range <small>note.3</small>	77~90Vdc	73~85Vdc	34~40Vdc		
	Current ADJ. Range <small>note.3</small>	840~1400mA	888~1480mA	1890~3150mA		
	Voltage Tolerance	±1%	±1%	±1%		
	Voltage Line Regulation	±0.5%	±0.5%	±0.5%		
	Voltage Load Regulation	±0.5%	±0.5%	±0.5%		
Input	Efficiency	93.5%	93.5%	93.5%		
	Power Factor	0.97/230Vac	0.97/230Vac	0.97/230Vac		
	AC Current	1.5A/100Vac, 0.7A/230Vac				
	Leakage Current	<0.75mA/230Vac; <0.5mA/120Vac				
Output Protection	Over Current	Constant current limiting				
	Short Circuit	Non-dimmer type: recover automatically at hiccup; Dimmer type: Short-circuit power ≤10W.				
	Over Voltage	Shut down at 140% Vo and latch off o/p voltage, re-power on to recover				
Environmental	Operating Humidity	20~95% RH, non-condensing				
	Storage Humidity	10~95% RH				
	Temperature Coefficient	±0.03%/°C (0~50°C)				
	Vibration	10~300Hz, 1G, Period for 60min, each along X、Y、Z axes.				
Safety & EMC	Withstand Voltage	I/P-OP: 3.75KVac; IP-FG: 1.56KVac/2.00KVac (remove discharge tube); O/P-FG: 2.00KVac				
	Isolation Resistance	IP-OP, IP-FG, O/P-FG: 100M Ohms/500Vdc/25°C/70% RH				
	EMC Interference	Compliance to EN55015, EN55022 (CISPR22) Class B				
	EMC Emission	Compliance to EN61000-3-2 Class C (≥50%load); EN61000-3-3				
	EMC Immunity	Compliance to EN61000-4-2, 3, 4, 5, 6, 8, 11; ENV50204, EN61547, EN55024				
Others	Authentication	CE/RoHS/REACH				
	MTBF	211k Hrs at full load and 30°C ambient conditions per MIL-HDBK-217F				
	Input Over-voltage	Can survive input over-voltage stress of 320Vac for 48 hours				
	Dimensions (mm)	215×68×41.3				
	Max. Case Temp.	Tc max=80°C				
	Net Weight	1.07Kg/pcs				
Note	1. All parameters NOT specially mentioned are measured at 230Vac input, rated load and 25°C of ambient temperature.					
	2. Ripple & noise are measured: at 20MHz of bandwidth by using a 12" twisted pair-wire terminated with a 0.1µf & 47µf parallel capacitor.					
	3. Output voltage and current can be adjusted by internal potentiometer ("A" type only).					
	4. Tolerance: includes set up tolerance, voltage line regulation and voltage load regulation.					
	5. Constant current operation region is within 60% ~100% rated output voltage. This is the suitable operation region for LED related applications, but please reconfirm special electrical requirements for some specific system design.					
	6. Derating may be needed under low input voltages. Please check the Static Characteristics for more details.					
	7. Safety and EMC design refer to EN60598-1, subject 8750 (UL), CNS15233, GB7000.1, FCC part18.					
	8. Length of set up time is measured at cold first start. Turning ON/OFF the power supply may lead to increase of the set up time.					
	9. The power supply is considered as a component that will be operated in combination with final equipment. Since EMC performance will be affected by the complete installation, the final equipment manufacturers must re-qualify EMC Directive on the complete installation again.					

## ■ Part number code

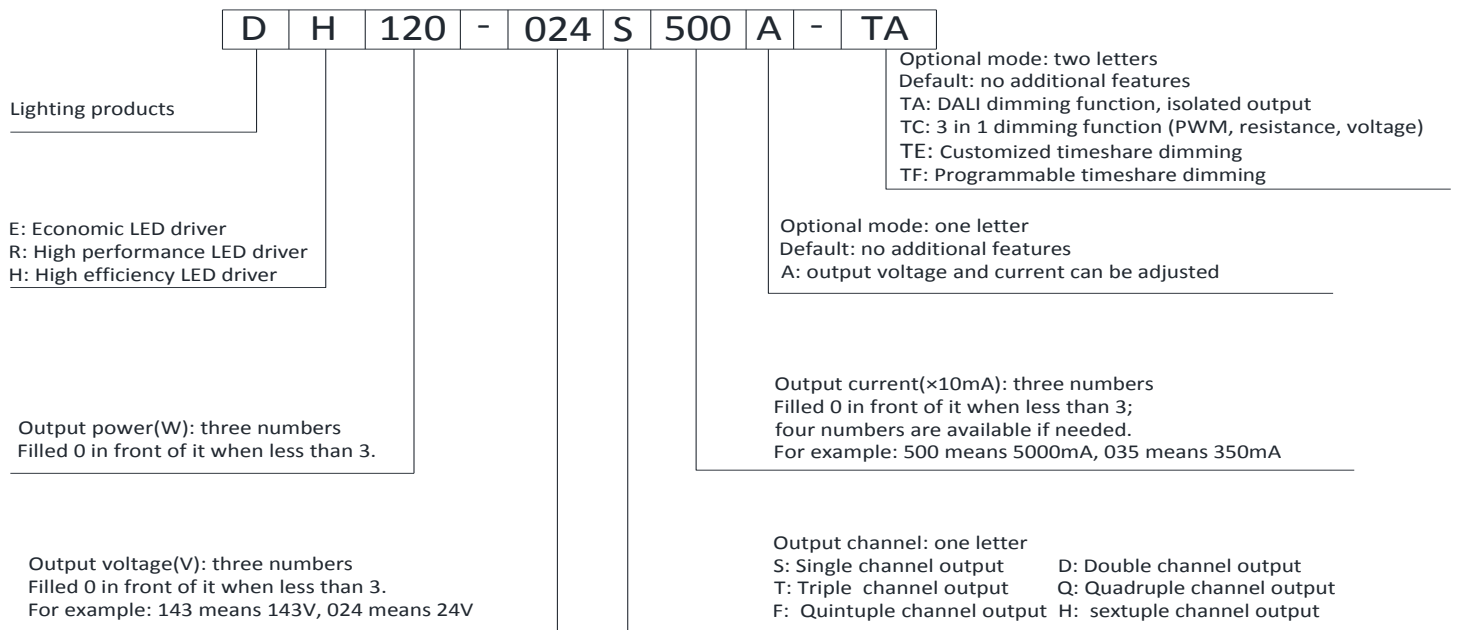

For example: DH120-024S500A-TA means: high efficiency LED driver; output power 120W; output voltage 24Vdc; output current 5000mA; single output; output voltage and current can be adjusted; with DALI dimming function and isolated output.

## ■ wiring diagram

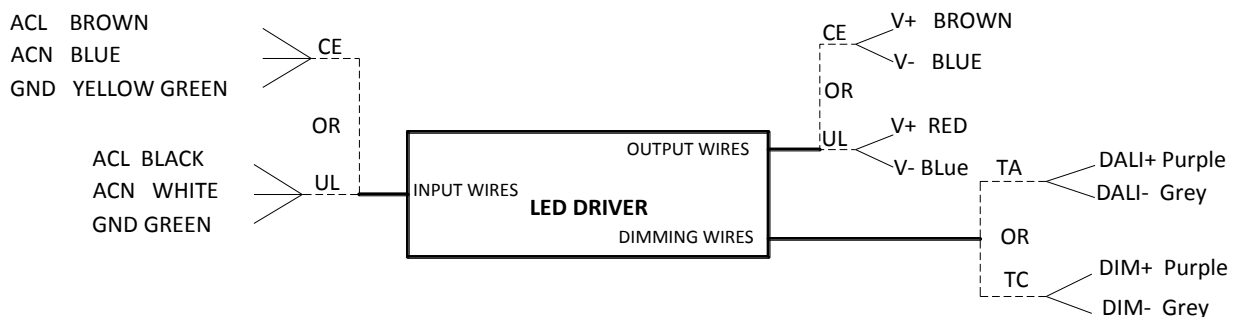

## ■ Derating Curve

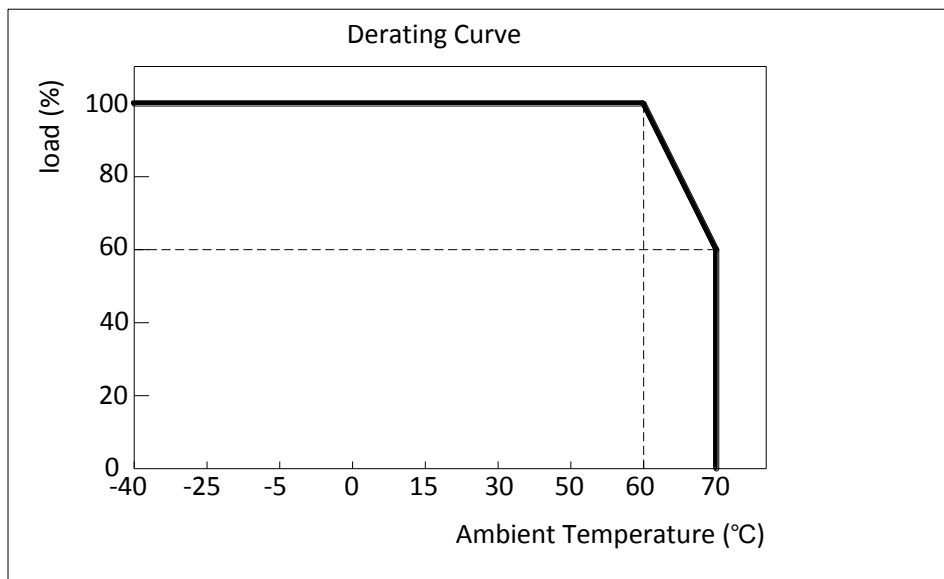

## ■ Static Characteristics

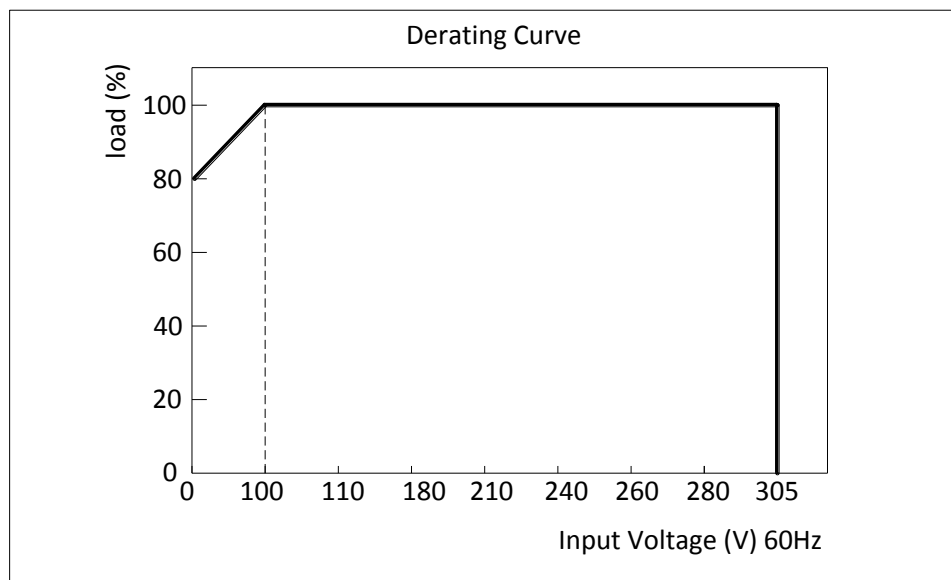

## ■ Power Factor Characteristic (DH120-024S500)

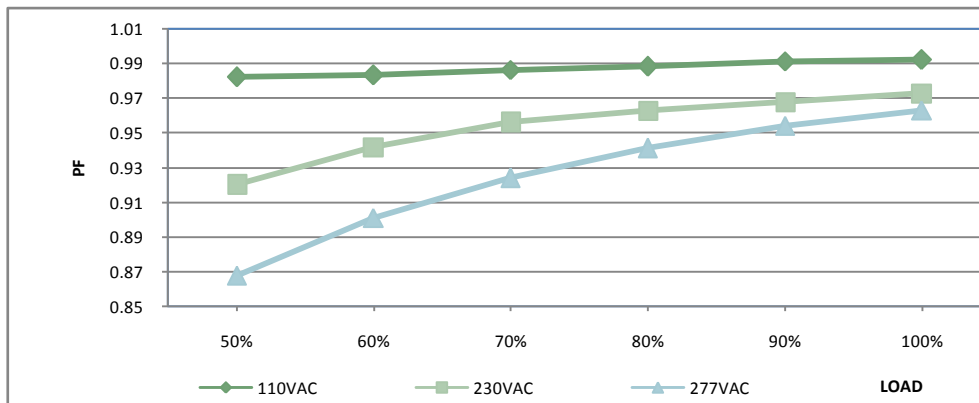

## ■ EFFICIENCY vs LOAD (DH120-024S500)

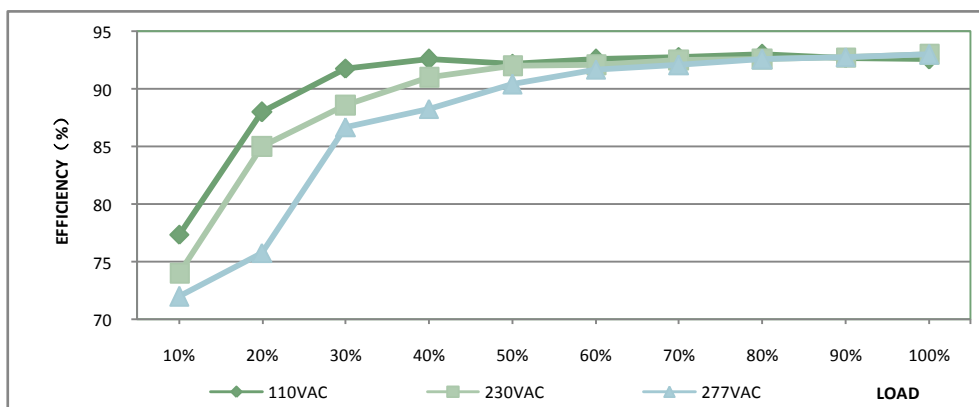

## ■ Typical LED power supply I-V curve

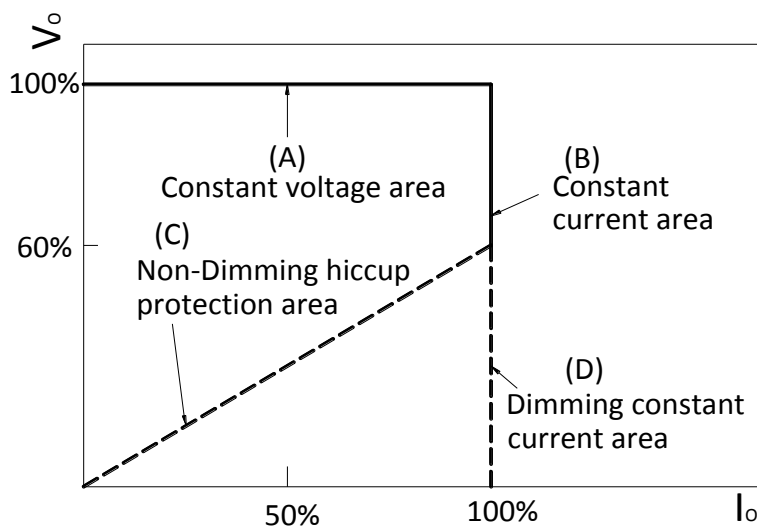



## ■ Mechanical Outline

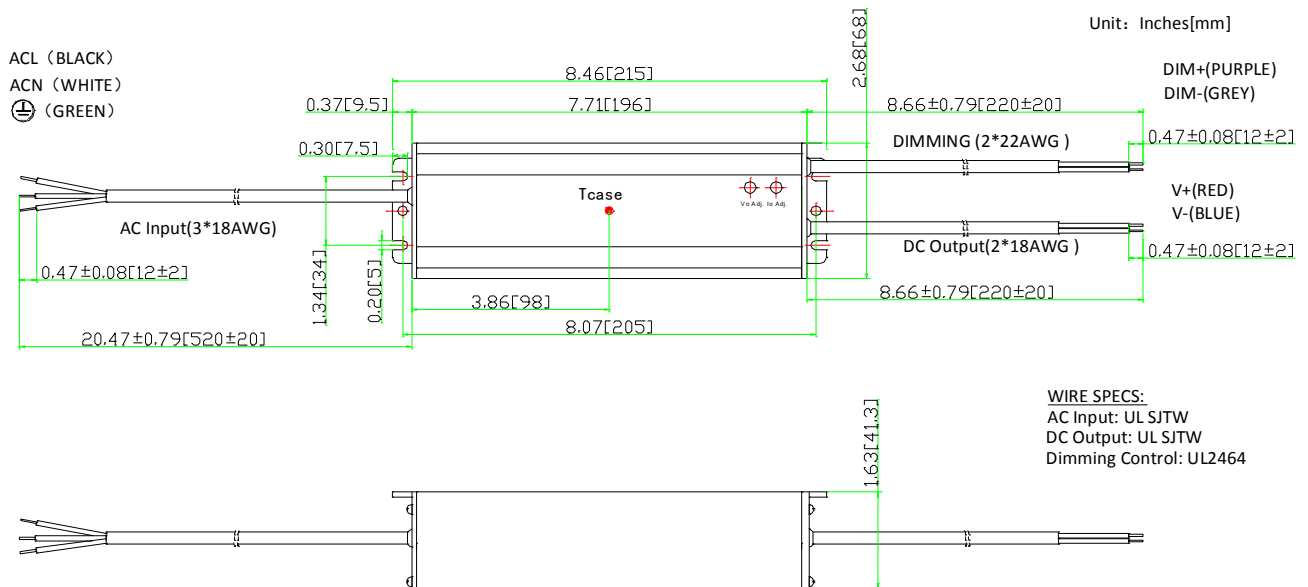

- ※ Tcase: Max. Case Temperature.
- ※ Power's internal temperature is 10°C warmer than case temperature.
- ※ No dimming control wire if without dimming function.
- ※ Please DO NOT connect "DIM -" to "V -" (load)

NO.	DC Output Current	Wire Number	Wire specification
1	≤5A	1	2×AWG18
2	5~12A(Including 12A)	1	2×AWG16

## ■ "A" option

- a. Output voltage and current can be adjusted by internal potentiometer.
- b. IP65.
- c. These products shall be enclosed in the end product, when the unit provided with voltage and current adjustable holes.

## ■ "-TA" option: DALI dimming

- a. DALI Testing Software: Please refer to [www.impowercorp.com](http://www.impowercorp.com) for downloading.
- b. Percentage of rated current: 10%~100%.
- c. "TA" version LED driver shall work with a DALI Master and DALI Master control software.



## ■ “-TC” option: 0-10V, resistance & PWM dimming

a. Reference resistance value for output current adjustment (Typical)

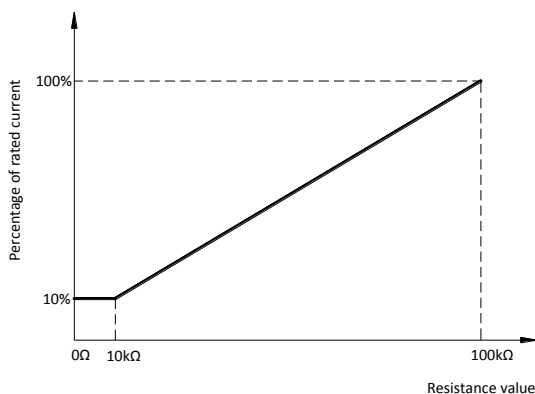

b. 0-10V dimming function for output current adjustment (Typical)

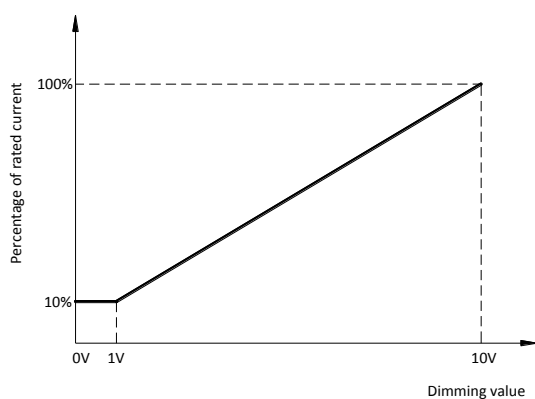

c. 10V PWM signal for output current adjustment (Typical): Frequency range: 200Hz~1.5KHz

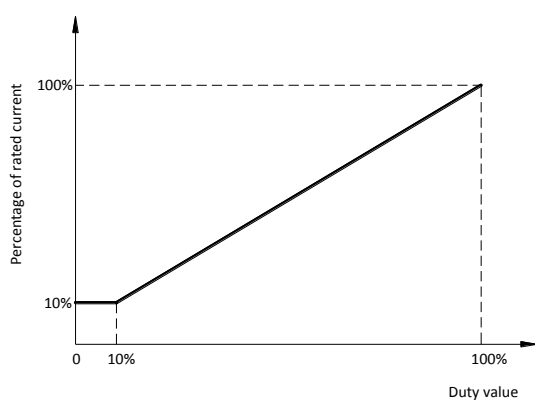

Dimming control details:

Parameters		Minimum	Typical	Maximum
Dimming Type	Resistance	0kΩ	0-100kΩ	∞
	Voltage	-2V	0-10V	15V
	PWM(10%~100% f=200Hz~1.5KHz)	-2V	0-10V	15V
Dimming Current		-0.5mA	-	0.5mA

## ■ "-TE" option: Customized timeshare dimming.

- Different output current (10% - 100% rate output current) can be set for different time periods.
- Maximum 4 sections is available. The minimum length is 0 to maximum 12 hours for each section.
- The parameter can't be changed after shipping.

## ■ "-TF" option: Programmable timeshare dimming.

- Output current is programmable with the range of 10%~100% of rated output current.
- Maximum 4 sections timeshare dimming is available. The minimum length is 0 to maximum 12 hours for each section.

For example:

The first section: the time period is 0~1h, the output current is 40% of rated output current.

The second section: the time period is 1h~4h, the output current is 100% of rated output current.

The third section: the time period is 4h~8h, the output current is 40% of rated output current.

The fourth section: the time period is 8h~12h, output current is 60% of rated output current.

- The parameters are set by a programmer.
- The data interface is waterproof.

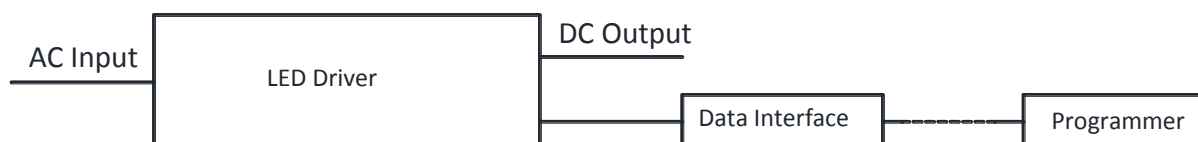

## ■ Input and output Dielectric strength

Isolation	Input Wires	Output Wires	Isolated Dimming Control Wires	Chassis
Input Wires	NA	3750	2000	1560/2000(remove discharge tube)
Output Wires	3750	NA	2000	2000
Isolated Dimming Control Wires	2000	2000	NA	2000
Chassis	1560/2000(remove discharge tube)	2000	2000	NA

## ■ Fixed derating-cutoff type temperature protection

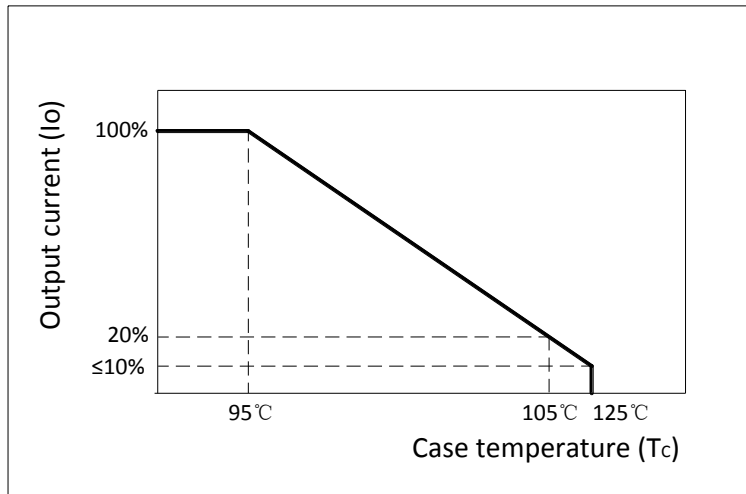

This datasheet is for reference only. Impow reserves all rights for final explanation of the technical materials.