



SPECIFICATION

TO:STE1074

Model Name: SAW FILTER

PART NO: SSF465W02S3838

CUSTOMER PART NO.:

1. Package Dimension

(S3838)

Unit: mm

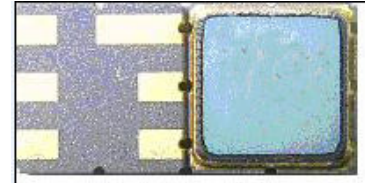
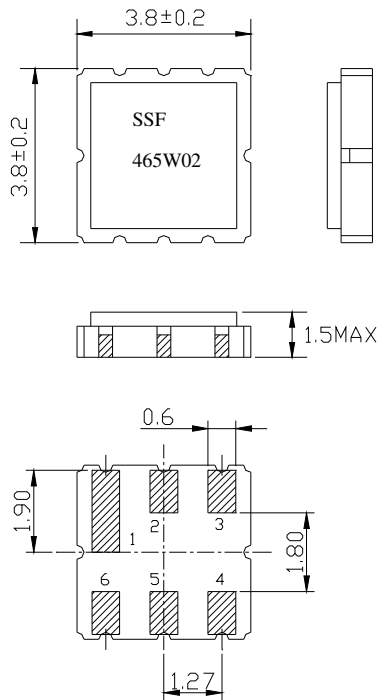

Pin No.	Function
Pin 2	Input
Pin 5	Ouput
Other	Ground

2. Marking

SSF
465W02

- (1) Ink Marking or Laser Marking
- (2) 465W02: Model code
- (3) • : Pin 1 Identifier
- (4) 05: Year
- (5) 51: Week

I
Month code

5
Last figure of year

Month	1	2	3	4	5	6	7	8	9	10	11	12
Month code	A	B	C	D	E	F	G	H	I	J	K	L

3. Performance

3.1 Application

RF SAW filter for telecommunications.

Center frequency(fo): 465.0MHz

3.2 Maximum Rating

Operation Temperature Range	-20°C to +50°C
Storage Temperature Range	-40°C to +85°C
DC Permissive Voltage	10V DC max.
Maximum Input Power	0 dBm

3.3 Electronic Characteristics

Item	Frequency	Specification
Center Frequency (fo)	465.0 MHz	
Insertion Loss	fo ± 2.0 MHz	4.5dB max.
Passband Ripple	fo ± 2.0 MHz	2.0dB max.
Stop Band Attenuation	fo-100 MHz ~ fo-40.8 MHz	50dB min.
	fo+40.8 MHz ~ fo+100 MHz	50dB min.
Terminating Impedance		50 Ω / 0pF

3.4 Frequency Characteristics

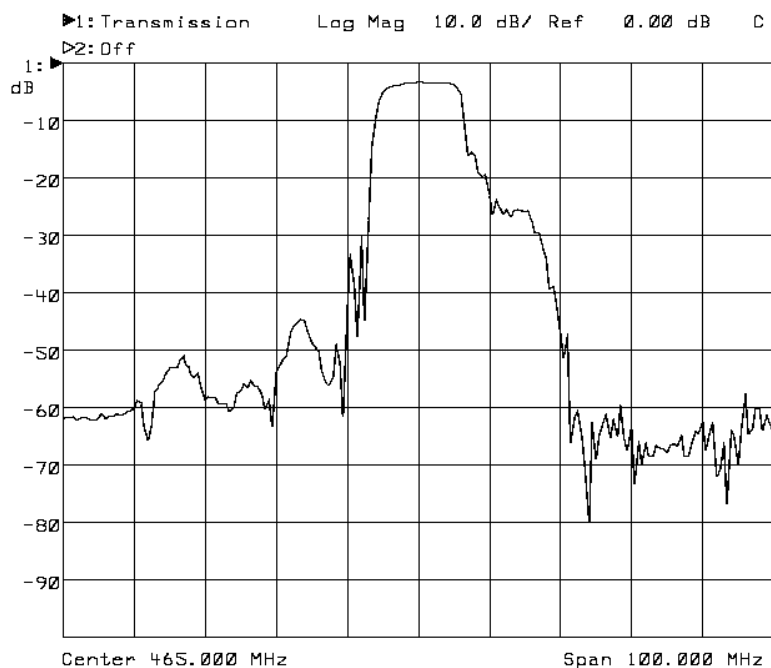

3.5 Test Circuit

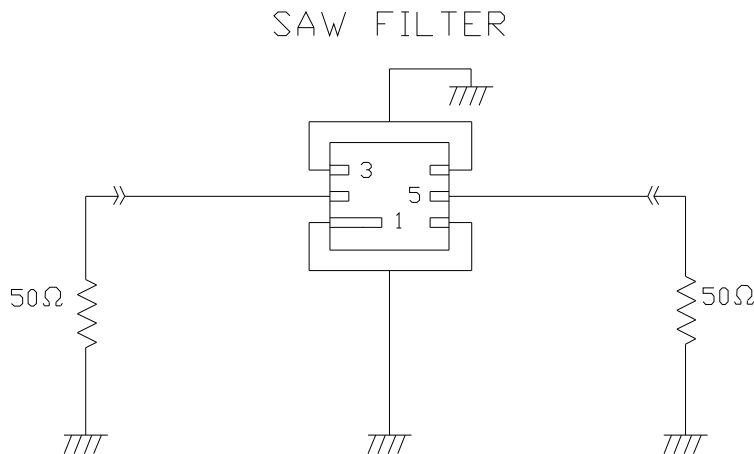

4 Reliability

4.1 Mechanical Shock: The components shall remain within the electrical specifications after three one-half sine shock pulses (3000g's for 0.3 ms) in each direction (for six total) along each of the three mutually perpendicular axes for a total of 18 shocks.

4.2 Vibration Fatigue: The components shall remain within the electrical specifications after loaded vibration at 20~55Hz, amplitude 1.5mm, X,Y,Z, direction, for 2 hours.

4.3 Leak Test

4.3.1 Gross Leak Test: Submerge samples into at +85°C water for at least 1 minute. Carefully observe the samples. No bubbles should be seen.

4.3.2 Fine Leak Test: Expose samples for testing to 60 PSIG Helium gas for 2 hours. Then transfer the same

4.3.3 samples to another chamber and draw a vacuum. Measure the leak rate. Failure is defined if the leak rate exceeds 5×10^{-8} atm cc/sec Helium.

4.4 High Temperature Storage: The components shall remain within the electrical specifications after being kept at the $85^\circ\text{C} \pm 2^\circ\text{C}$ for 960 hours, then kept at room temperature for 2 hours.

4.5 Low Temperature Storage: The components shall remain within the electrical specifications after being kept at the $-40^\circ\text{C} \pm 2^\circ\text{C}$ for 960 hours, then kept at room temperature for 2 hours.

4.6 Temperature Cycle: The components shall remain within the electrical specification after 32 cycles of high and low temperature testing (one cycle: 80°C for 30 minutes \rightarrow 25°C for 20 seconds \rightarrow -40°C for 30 minutes) then kept at room temperature for 2 hours.

4.7 Humidity Test: The components shall remain within the electrical specifications after being kept at the condition of ambient temperature 70°C , and 90~95% RH for 240 hours, then kept at room temperature and normal humidity for 4 hours.

4.8 Solder-heat Resistance: The components shall remain within the electrical specifications after dipped in the solder at $260^\circ\text{C} \pm 5^\circ\text{C}$ for 10 to 11 seconds, then kept at room temperature for 10 minutes.

4.9 Solderability: Solderability of terminal shall be kept at more than 80% after dipped in the solder flux at $230^\circ\text{C} \pm 5^\circ\text{C}$ for 5 ± 1 seconds.

4.10 Storage: The components shall meet the electrical and mechanical specifications after 5 years storage, if stored within the temperature range of $-40^\circ\text{C} \sim +85^\circ\text{C}$ and in the humidity of 20 to 60% r.h.

5 Remarks

5.1 Static voltage

Static voltage between signal load & ground may cause deterioration & destruction of the component. Please avoid static voltage.

5.2 Ultrasonic cleaning

Ultrasonic vibration may cause deterioration & destruction of the component. Please avoid ultrasonic cleaning.

5.3 Soldering

Only leads of component may be soldered. Please avoid soldering another part of component.

6 Packing

6.1 Dimensions

(1) Carrier Tape: Figure 1

(2) Reel: Figure 2

(3) The product shall be packed properly not to be damaged during transportation and storage.

6.2 Reeling Quantity

1,000 pcs/reel

6.3 Taping Structure

(1) The tape shall be wound around the reel in the direction shown below.

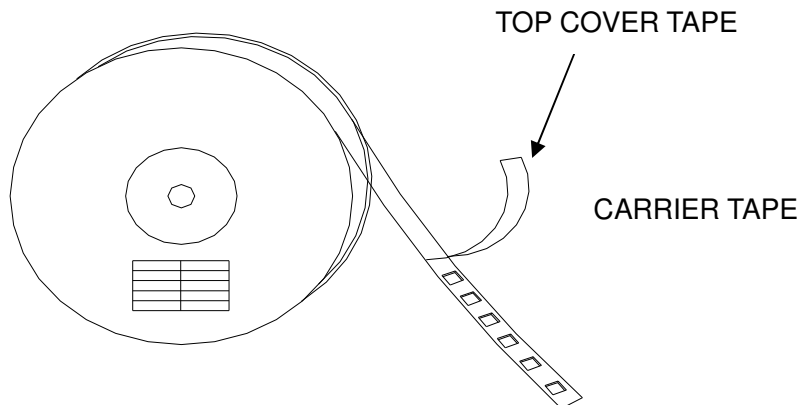

(2) Label

Device Name	
Type	
Quantity	
Lot No.	

(3) Leader part and vacant position specifications.

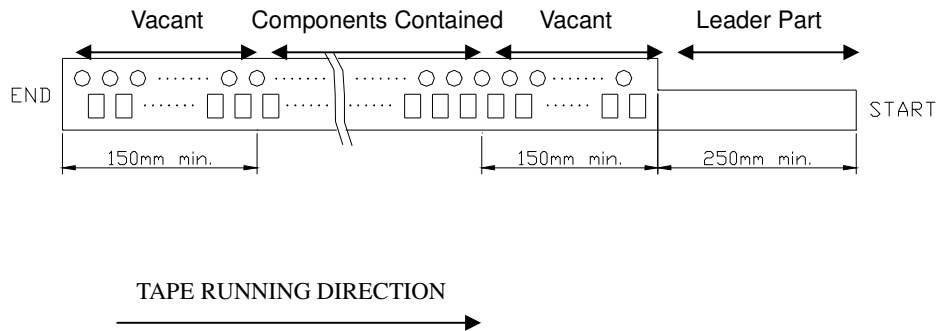

7 Tape Specifications

7.1 Tensile Strength of Carrier Tape: 4.4N/mm width

7.2 Top Cover Tape Adhesion (See the below figure)

- (1) pull off angle: 0~15°
- (2) speed: 300mm/min.
- (3) force: 20~70g

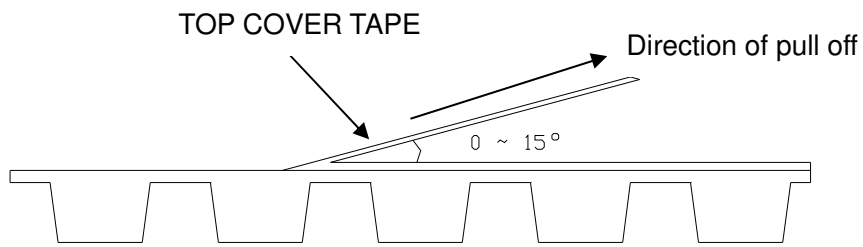

[Figure 1] Carrier Tape Dimensions

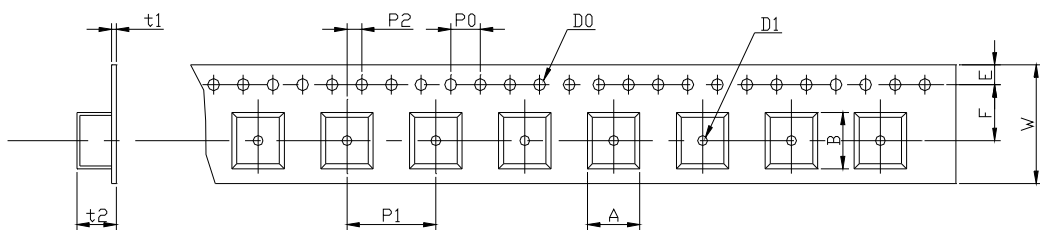

Unit: mm]

W	F	E	P0	P1	P2	D0	D1	t1	t2	A	B
12.0	5.5	1.75	4.0	8.0	2.0	Φ 1.5	Φ 1.5	0.31	1.95	4.1	4.1
±0.3	±0.1	±0.1	±0.2	±0.1	±0.2	±0.1	±0.25	max.	max.	max.	max.

[Figure 2] Reel Dimensions

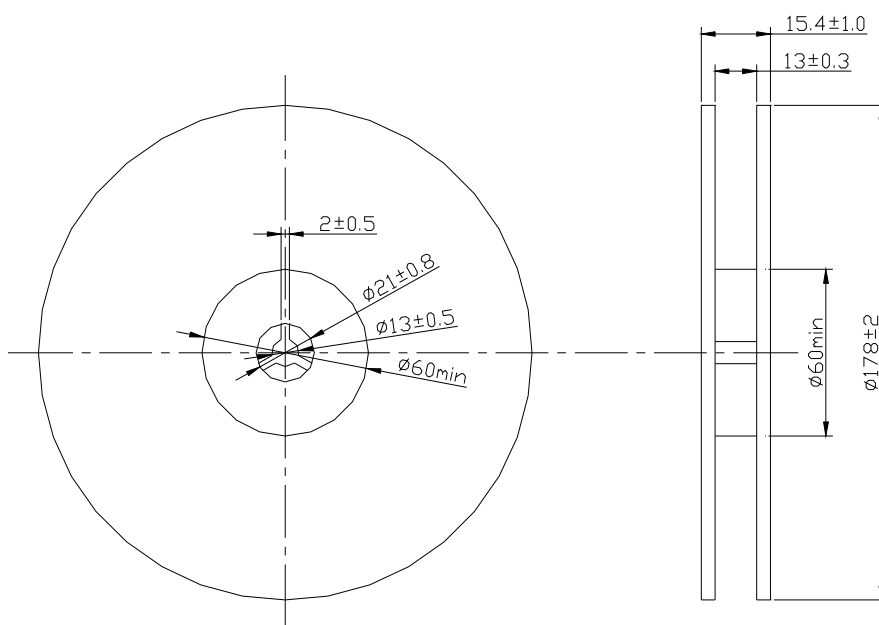

[Figure 3] Part Direction

Tape Running Direction