



SPEC NO.: SFS-109M

SPECIFICATION

TO:STE1020

Model Name: SAW FILTER

PART NO: SSF480W06TO39

CUSTOMER PART NO.:

STRONG ELECTRONICS&TECHNOLOGY LIMITED

Tel:86-755-84528985 Fax: 86-755-84528986

Email:info@strongelectronics.net

www.sawfilter.cn

1. Package Dimension

(TO-39B)

Unit: mm

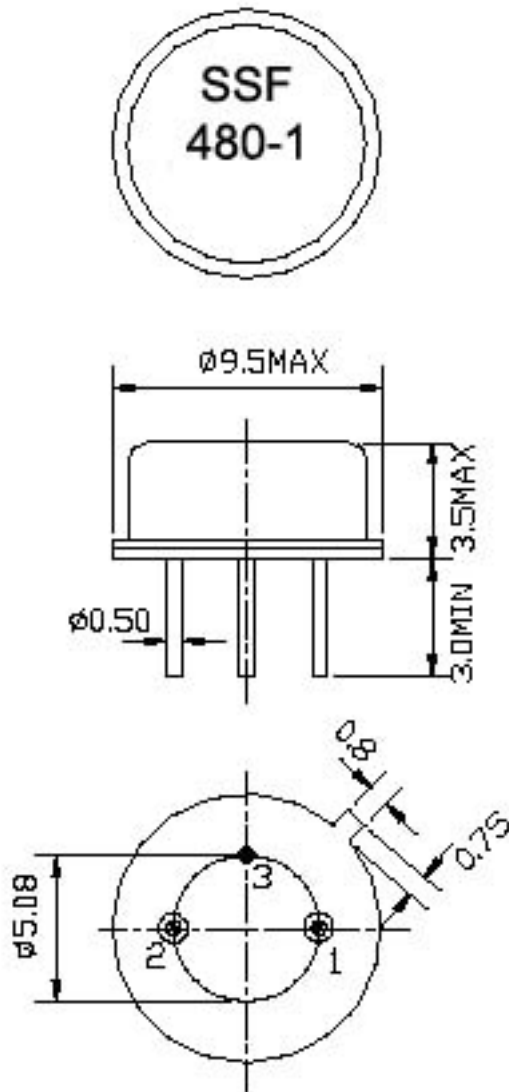

NO.	Function
1	Input/Output
2	Input/Output
3	GND

2. Marking

**SSF
480-6**

1. Black Ink Marking
2. SSF: Manufacture's log
3. 480MHz: Center frequency
4. W06: Series code

3. Performance

3.1 Maximum Rating

Item	Value
Operation Temperature Range	-40°C to +80°C
Storage Temperature Range	-40°C to +85°C
DC Voltage	0V (between any terminals)
AC Voltage	5V (between any terminals)

3.2 Electronic Characteristics

Item		Minimum	Typical	Maximum	Unit
Center Frequency	fc	478.5	479.5	480.5	MHz
Insertion Loss(479.5MHz)			18.0	21.0	dB
Insertion Loss 475.00 - 484.00 MHz	IL		18.0	22.0	dB
3dB Bandwidth	BW _{-3dB}	15.0	17.3		MHz
Amplitude Ripple (p-p) 475.00 - 484.00 MHz	$\Delta\alpha$		0.5	1.0	dB
Group Delay Ripple 472.00 - 487.00 MHz	$\Delta\alpha$		10.0	15.0	ns
Relative Attenuation	α				
430.00 – 458.00 MHz		35.0	40.0		dB
472.00 MHz			3.0	5.0	dB
487.00 MHz			3.0	5.0	dB
501.00 - 530.00 MHz		30.0	35.0		dB
Input VSWR 475.00 - 484.00 MHz			1.8:1	2.5:1	/
output VSWR 475.00 - 484.00 MHz			3.0:1	3.5:1	/

3.3 Frequency Characteristics

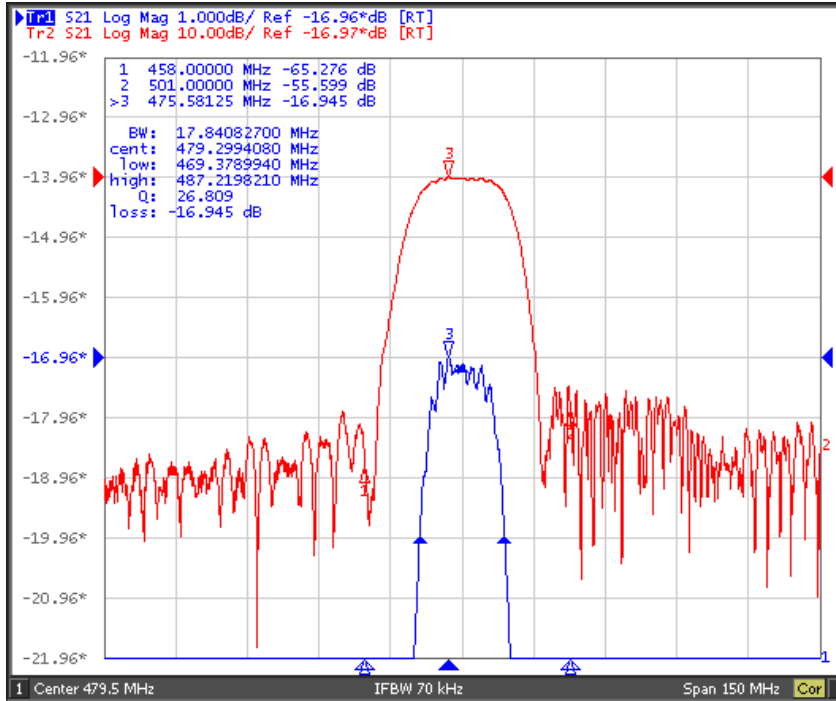

3.4

Test Circuit

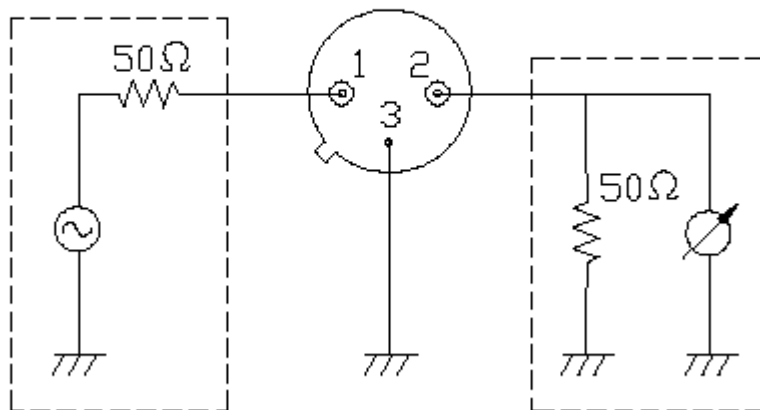

4. Reliability

4.1 Resistance to Soldering heat:

4.1.1 The components shall remain within the electrical specifications after it soldered on the 1mm-thickness PCB board and dipped in the solder at 260 ± 5 for 10 ± 1 seconds.

4.1.2 The components shall remain within the electrical specifications after it soldered by electric iron, solder at 350 ± 10 for 3~4 seconds, recovery time : $2h\pm 0.5h$.

4.2 Thermal Shock:

The components shall remain within the electrical specifications after being kept at the condition of heat cycle conditions: $TA=-40\pm 3$, $TB=85\pm 2$, $t1=t2=30min$, switch time $\leq 3min$ & cycle time : 100 times, recovery time : $2h\pm 0.5h$.

4.3 The Temperature Storage:

4.3.1 High Temperature Storage: The components shall remain within the electrical specifications after being kept at the 85 ± 2 for 500 hours, recovery time : $2h\pm 0.5h$.

4.3.2 Low Temperature Storage: The components shall remain within the electrical specifications after being kept at the -40 ± 3 for 500 hours, recovery time : $2h\pm 0.5h$.

4.4 Humidity test:

The components shall remain within the electrical specifications after being kept at the condition of ambient temperature 60 ± 2 , and 90~95% RH for 500 hours.

4.5 Drop test:

The components shall remain within the electrical specifications after random free drops 10 times from height of 1.0 meter onto concrete floor, and the specimens shall meet the electrical specifications in table 5, external visual inspection.

4.6 Solderability test:

at the condition of temperature $245^{\circ}C\pm 5^{\circ}C$ Depth: DIP 2/3 , SMD 1/5, time: 3.0s-5.0s, 80% or more of the immersed surface shall be covered with solder and well-proportioned.

4.7 Vibration Fatigue:

The components shall remain within the electrical specifications after loaded vibration at 10~55Hz, amplitude 1.5mm, X, Y, Z, direction, for 2 hours.

4.8 Terminal strength:

The force 10 ± 1 seconds of 19.6N is applied to each terminal, and 45° in the same direction 2 times with 2N bending force (Exception: SMD)

4.9 Mechanical Shock:

The components shall remain within the electrical specifications after 1000 shocks,

acceleration 392 m/s^2 , duration 6ms.

Note: As a result of the particularity of inner structure of SAW products, it easy to be breakdown by electrostatic, so we should pay attention to ESD protect in the test.

5. Remarks

5.1 Static voltage

Static voltage between signal load & ground may cause deterioration & destruction of the component. Please avoid static voltage.

5.2 Ultrasonic cleaning

Ultrasonic vibration may cause deterioration & destruction of the component. Please avoid ultrasonic cleaning.

5.3 Soldering

Only leads of component may be soldered. Please avoid soldering another part of component.