

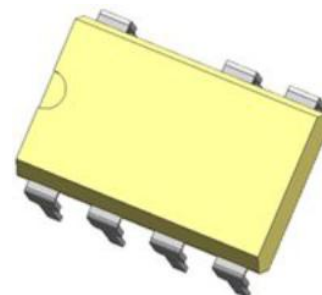

WAS1/D1.2P22——1.2A 700V SSR

概述 Features

- 调相型 Random trigger
- 负载电流至1.2A Load current up to 1.2A
- 阻断电压700V Peak off-state voltage 700V
- 符合RoHS RoHS compliant



获得认证 Agency Approvals

- UL - E518877
- cUL - E518877
- TUV - R 50486556

应用 Applications

- 家电产品（空调、冰箱、洗衣机微波炉等的风扇、加热、进出水开关等控制）
Home appliances (air conditioners, microwave ovens, washing machines, personal hygiene systems, refrigerators, fan heaters, inductive heating cooker, and water heaters, etc.)
- 工业控制 Industrial equipment.

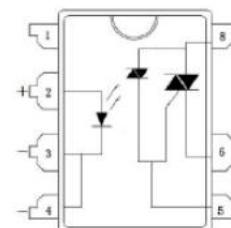

打印标志 Marking Information

Part Number	Package	Marking
WAS1/D1.2P22	DIP7	WAS1 D1.2P22
WAS1/D1.2P22S	SMD7	WAS1 D1.2P22



极限值 Absolute Maximum Ratings

(Ta=25°C)

特性参数/Parameter		符号/Symbol	测试条件/Test Condition	最小值/Min.	典型值/Typ.	最大值/Max.	单位/Unit
输入端/Input	反向电流/LED reverse current	I_R	$V_r=5V$			10	μA
	正向电流/LED forward current	I_F				50	mA
输出端/Output	断态泄漏电流/Output off-state leakage current	I_R	$V_b=700V$			10	μA
	阻断电压/Repetitive peak off-state voltage	V_{DRM}				700	V
	额定电流/On-state RMS current	I	$I_F=10mA$			1200	mA
	浪涌电流/Surge current	I	50Hz, 1 cycle		12000		mA



电参数 Electrical Parameters

(Ta=25℃)

特性参数/Parameter		符号 /Symbol	测试条件 /Test condition	最小 值 /Min.	典型值 /Typ.	最大值 /Max.	单位 /Unit
输入端 Input	正向电压 /LED forward voltage	V_F	$I_F=10mA$		1.2	1.3	V
输出端 Output	额定电流 / On-state RMS current	I	$I_F=10mA$			1200	mA
	维持电流 /Holding current	I_H				50	mA
	电压指数上升率 /Critical rate of rise of off-state voltage	dv/dt	$V_{DM}=600V*1/\sqrt{2}$	200			V/ μs
耦合特性 Transfer characteristics	LED 触发电流/LED trigger current *	I_{FT}		5	8	10	mA
	推荐的工作电流 /Recommend operating current	I_{IN}		10		18	mA
	导通电压降 /Output on-state voltage drop	V	$I_F=10mA, I_L=1200mA$ $V_b=6V$		1.1	2.0	V
	导通时间/ Turn on time	t_{on}	$I_F=10mA,$ $V_b=6V, R_L=100\Omega$		0.01	1	ms
	关断时间/Turn off time	t_{off}				1+1/2cycle	ms
	介质耐压 / Dielectric strength *	V_{ISO}	$I_{off}\leq 0.5mA$	4000			V_{rms}
	工作温度/Operating temperature	T		-30		85	℃
储存温度/Store temperature			-40		125		

备注：1、介质耐压超过 3000V 建议在油里测试，在测试前请务必确认输入端和输出端已经分别短路。
2、带“*”参数为关键参数。



外形尺寸 Outline dimension :mm

1、DIP7

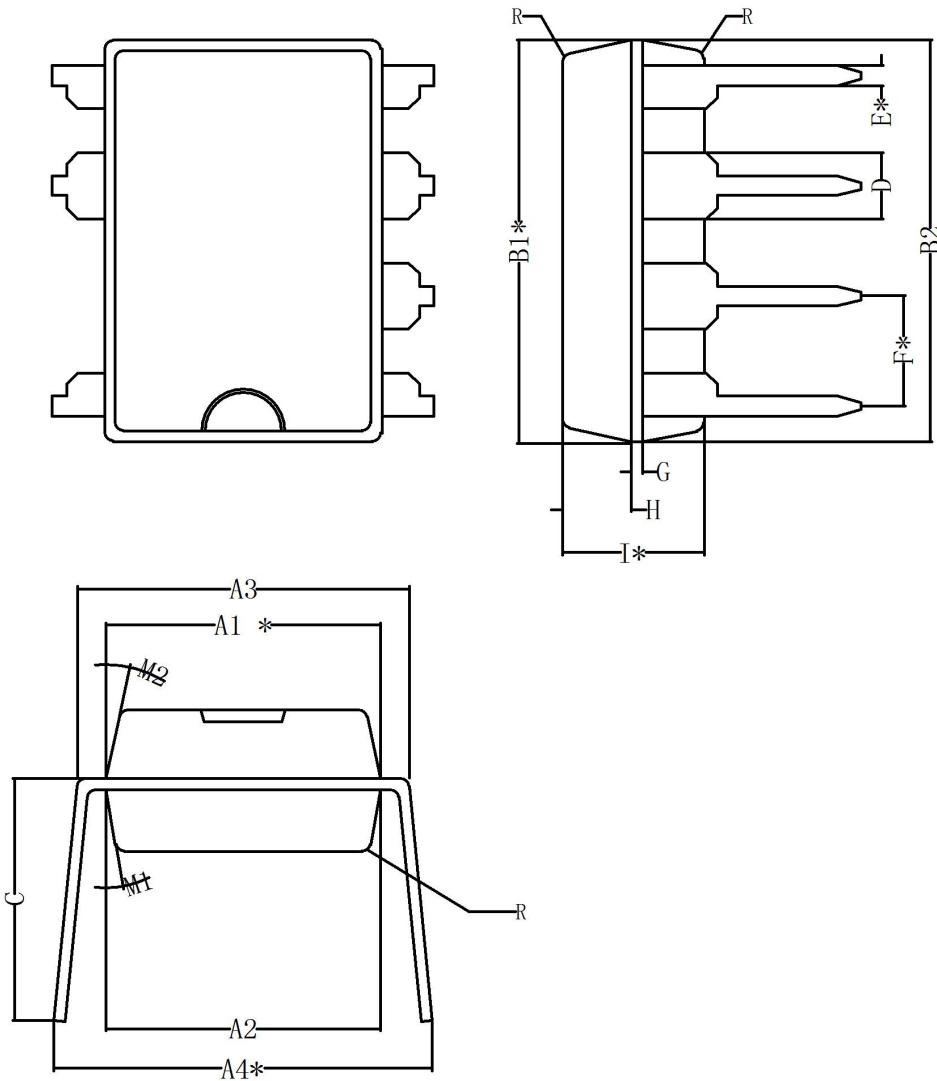

符号	最小	典型	最大	符号	最小	典型	最大
A1*	6.13	6.33	6.53	E*	0.34	0.42	0.50
A2	6.22	6.42	6.62	F*		2.54	
A3	7.32	7.62	7.92	G		0.25	
A4*	8.10	8.40	8.70	H	1.39	1.59	1.79
B1*	9.00	9.20	9.40	I*	3.07	3.27	3.47
B2	9.05	9.25	9.45	R		0.20	
C		5.57		M1		10°	
D		1.52		M2		12°	

注1: 未注公差请按±0.2;
 注2: 带“*”尺寸为关键尺寸。



2、SMD7

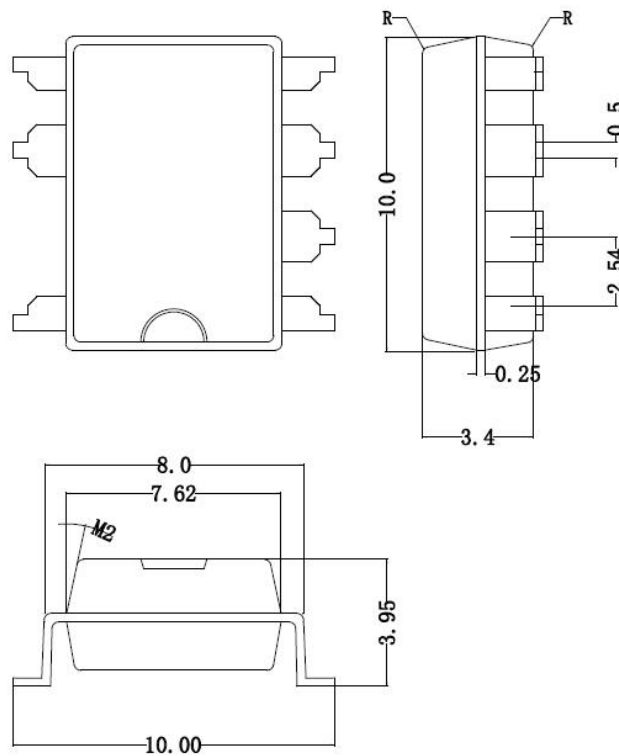

注：未注公差请按±0.2。

订货信息 Ordering Information

订货信息/Ordering Information								
	W	AS	1/	D	1.2	P	22	S
公司商标代号 Company symbol								
交流输出型 AC SSR								
封装 Package: 1: DIP7								
输入端电流型 Current driving: D								
负载电流 Load current: 0.6—0.6A;1.2—1.2A;								
P:调相 Non zero-cross Z:过零 Zero-cross;								
负载电压 Load voltage: 22:220Vac;38:380Vac								
S :SMD								



包装信息 Package specification

DIP7:

每管最多装50个/MAX. 50pcs of products shall be packaged in a sleeve;
每盒最多装40条/MAX. 40 sleeves in one case.

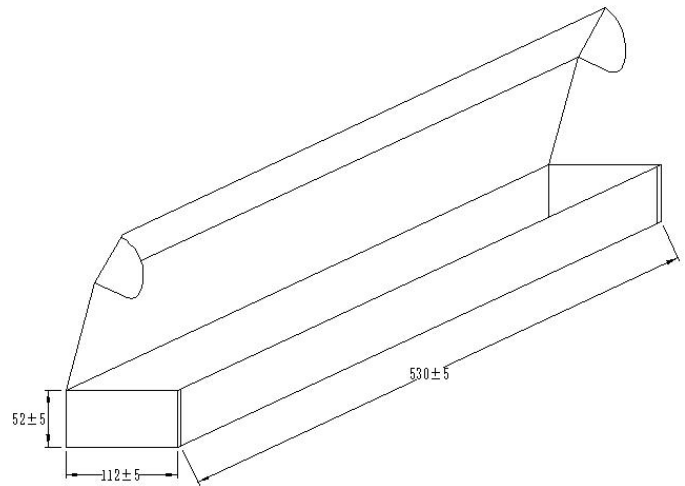
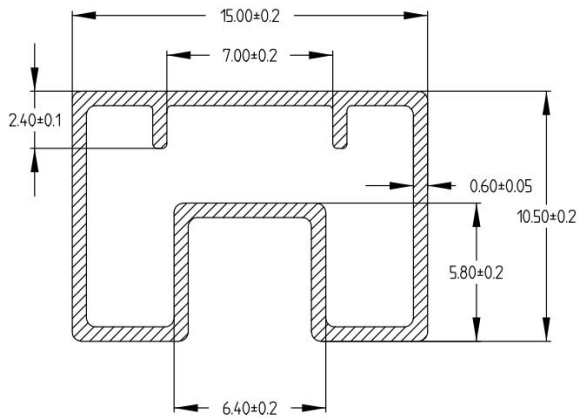

SMD7:

每管最多装50个/MAX. 50pcs of products shall be packaged in a sleeve;
每盒最多装30条/MAX. 30 sleeves in one case.

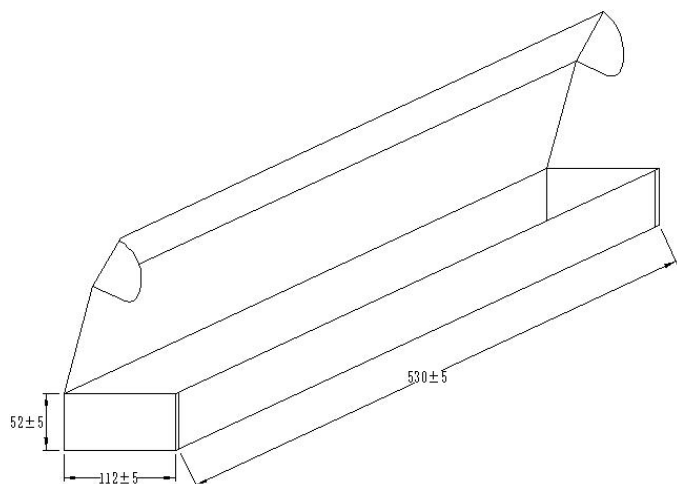
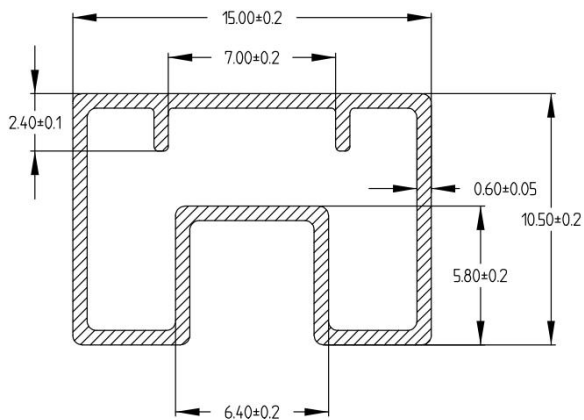



安规要求 Safety and Insulation Ratings

爬电距离	Creepage distance	5.0mm, CTI \geq 275;
瞬时过电压	Highest allowable overvoltage	5000V;
再现峰值电压	V_{IORM}	769V;
局部放电	Partial discharge test voltage Method b, $V_{Pd} = V_{IORM} \times 1.6$	1230V.

特性曲线 Characteristic Data

1. 负载电流与环境温度关系曲线

Load current VS. Ambient temperature

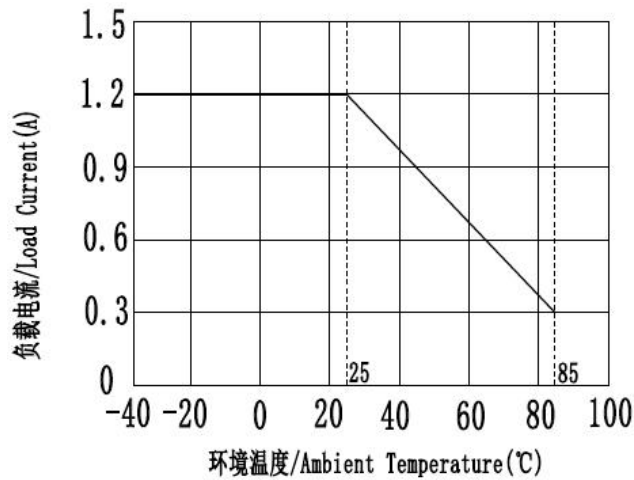

2. 导通压降—环境温度特性

On-state voltage drop VS. Ambient temperature

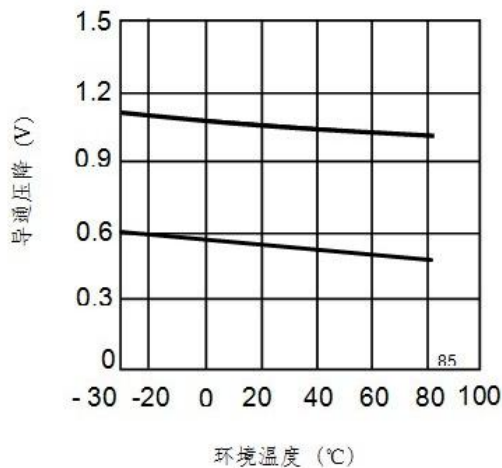

3. LED触发电流—环境温度特性

Trigger LED current VS. Ambient temperature

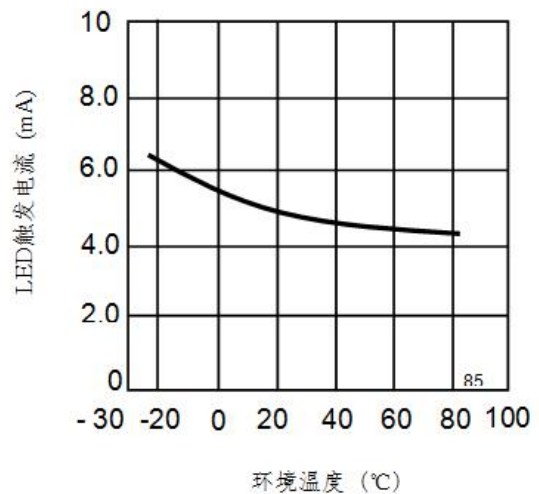



4. LED 导通压降—环境温度特性

LED dropout voltage vs. Ambient temperature
LED current: 10 to 50 mA

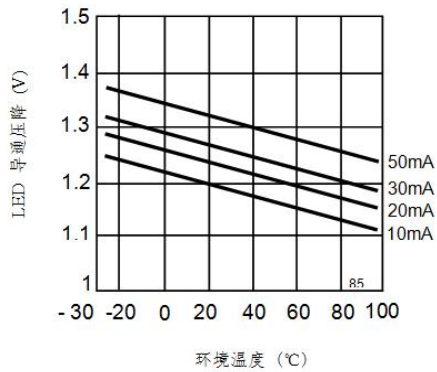

5. 导通时间—LED 电流特性

Turn on time vs. LED current

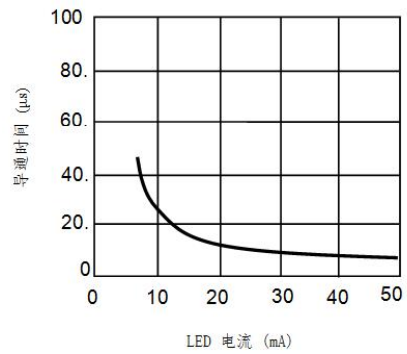

接通和关断时间关系 Turn on and Turn off time

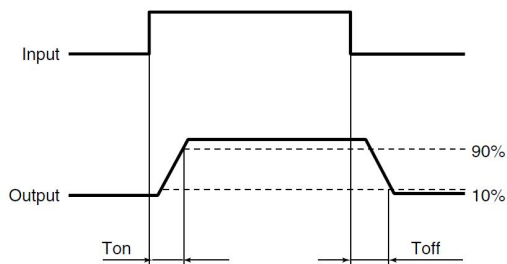

接线图 Wiring diagram

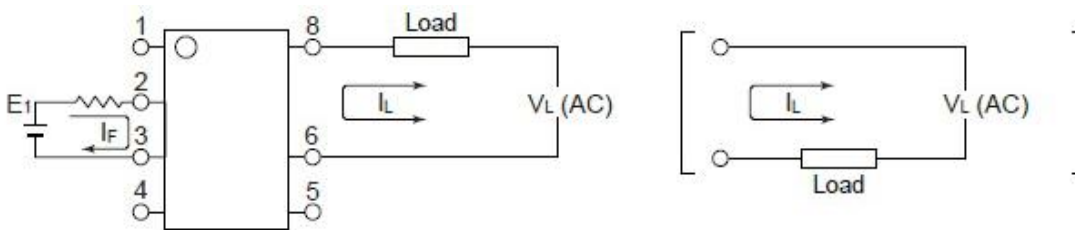



注意事项 Notes

- a) 工作环境温度超过 25℃时请降额使用，降额曲线参考附件。
When ambient temperature is above 25℃, the load current must be reduced. (see Characteristic Data 1)
- b) 继电器接线时，务必保证输入端极性的正确，以免损坏继电器。
Ensuring the polarity is correct when connecting the input lines, otherwise the wrong connection will damage the relay.
- c) 由于 SSR 动作时间很短，输入端的噪声可能会引起 SSR 误动作，所以在输入端环境噪声较大时，应在输入端接 R/C 回路吸收噪声。
Since the operate time of the relay is extremely short, any noise to input terminal will cause malfunction of the SSR, So a RC circuit should be connected to input terminal to absorb the noise in the noisy condition.

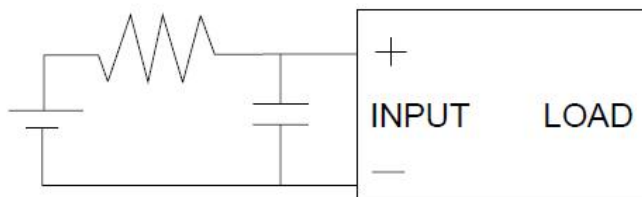

- d) 推荐的使用电路，输出端的尖峰电压可能会引起 SSR 误动作，所以请在输出端应加 R/C 回路或压敏电子吸收尖峰电压，具体见下图：
Below shows a recommend circuit: Please add a RC circuit or varistor on the load side, as noise/surge could damage the unit or cause malfunctions.

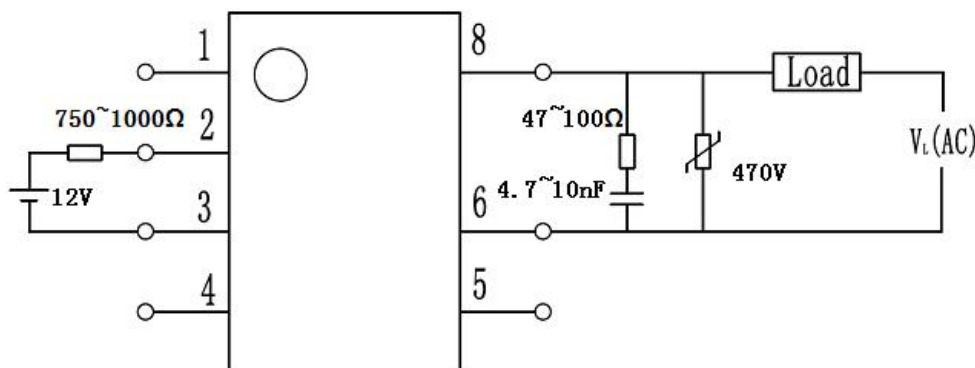

关于防静电对策 Cautions for Static Electricity

- a. 使用电烙铁时，对电烙铁前端进行接地。(建议使用低电压用的电烙铁。) When using soldering irons, either use irons with low leakage current, or ground the tip of the soldering iron. (Use of low-voltage soldering irons is also recommended.)
- b. 组装时使用的设备等也应正确地接地。Devices and equipment used in assembly should also be grounded.

关于焊接 Soldering

继电器焊接, 260 度情况下焊接时间不能超过 10 秒钟, 350 度情况下焊接时间不能超过 5 秒钟。
Soldering must be completed within 10 seconds at 260℃ or within 5 seconds at 350℃.