

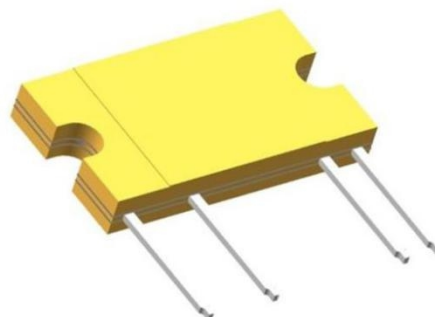

## YES2/10A60V——10A60V Opto-MOS

### 概述 Features

- 光电隔离 Optoelectronics isolation
- 负载最大电流为10A Max load current to 10A
- 高负载电压60V High load voltage 60V
- 介质耐压2500V Dielectric strength 2500V
- 符合RoHS RoHS compliant



### 应用 Applications

- 开关电源 Switching Mode Power Supply
- 交通信号控制 Traffic signals
- 测试设备 Measuring instruments
- 工业设备 Industrial machines

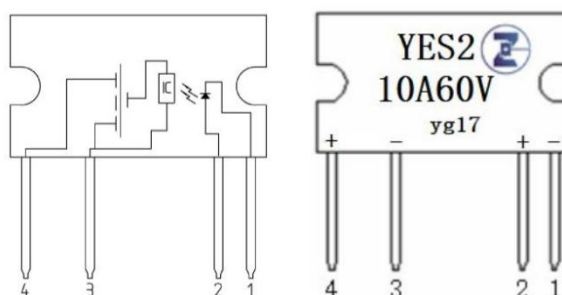

### 打印标志 Marking Information

Part Number	Package	Marking
YES2/10A60V	SIP4	YES2 10A60V

### 极限值 Absolute Maximum Ratings

(Ta=25℃)

特性参数/Parameter		符号/Symbol	测试条件/Test Condition	最小值/Min.	典型值/Typ.	最大值/Max.	单位/Unit	
输入端/Input	反向电流/LED reverse current	$I_R$	$V_R=5V$			10	$\mu A$	
	正向电压/ LED forward voltage	$V_F$	$I_f=10mA$		1.2	1.3	V	
	功耗/Power dissipation	$p_{in}$			75		mW	
输出端/Output	断态泄漏电流/Output off-state leakage current	$I_R$	$V_D=60V$			10	$\mu A$	
	功耗/Power dissipation	$p_{out}$			2/3 (带散热器)	2.4/4 (带散热器)	W	
	额定电流/ On-state RMS current	$I$				不带散热器	10	A
						带散热器	15	
峰值电流/ Peak current	$I$	A connection: 100 ms (1 shot), V <sub>L</sub> = DC			不带散热器	40	A	
					带散热器	50		



电参数 **Electrical Parameters**

特性参数/Parameter	符号 /Symbol	测试条件 /Test condition	最小 值 /Min.	典型值 /Typ.	最大值 /Max.	单位 /Unit
LED 触发电流/LED trigger current *	$I_{FT}$		5	8	10	mA
推荐的工作电流 /Recommend operating current	$I_{IN}$		10		18	mA
导通电阻/Output on-state resistance	$R_{ON}$	$I_F=10mA, I_D=5A$		不带 散热器 10	20	$m\Omega$
		$I_F=10mA, I_D=10A$		带散 热器 20	50	
耦合特性 Transfer characteristics 导通时间/Turn on time	$t_{on}$	$I_F=10mA, I_D=2A$			5	ms
关断时间/Turn off time	$t_{off}$	$I_F=10mA, I_D=2A$			1	
介质耐压/ Dielectric strength	$V_{ISO}$	$I_{on} \leq 0.3mA$	2500			$V_{rms}$
电容/ I/O capacitance	$C$			10		pF
工作温度/Operating temperature	$T$		-30		85	$^{\circ}C$
储存温度/Store temperature			-40		100	

外形尺寸 **Outline dimension :mm**

**SIP**

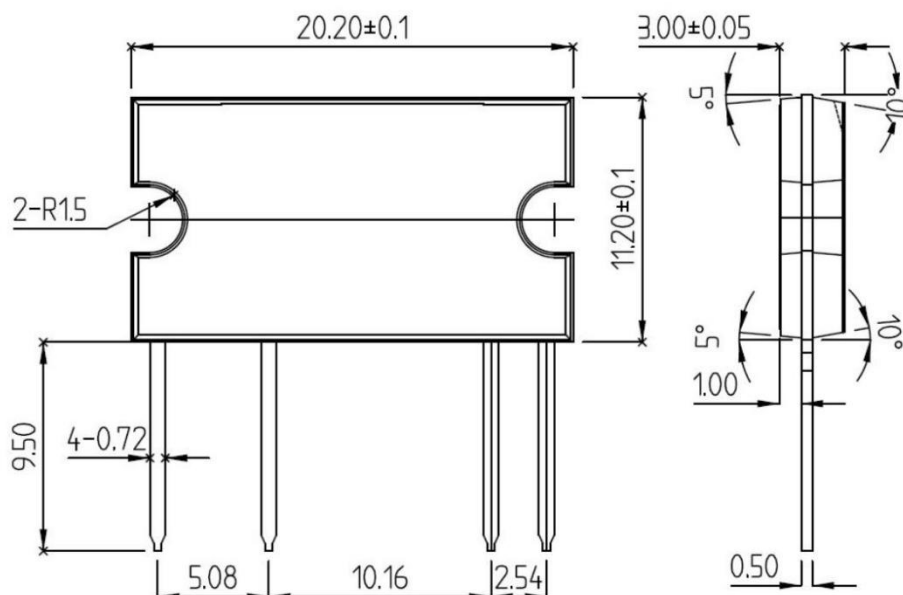



## 订货信息 Ordering Information

订货信息/Ordering Information						
	Y	ES	2/	10A	60	V
公司商标代号 Company symbol						
大电流 MOS 输出型 SSR						
封装 Package: 2: SIP4						
负载电流 load current: 10A						
击穿电压 BVDSS: 60-60V						
电压单位						

## 特性曲线 Characteristic Data

1. 负载电流与环境温度关系曲线  
Load current VS. Ambient temperature

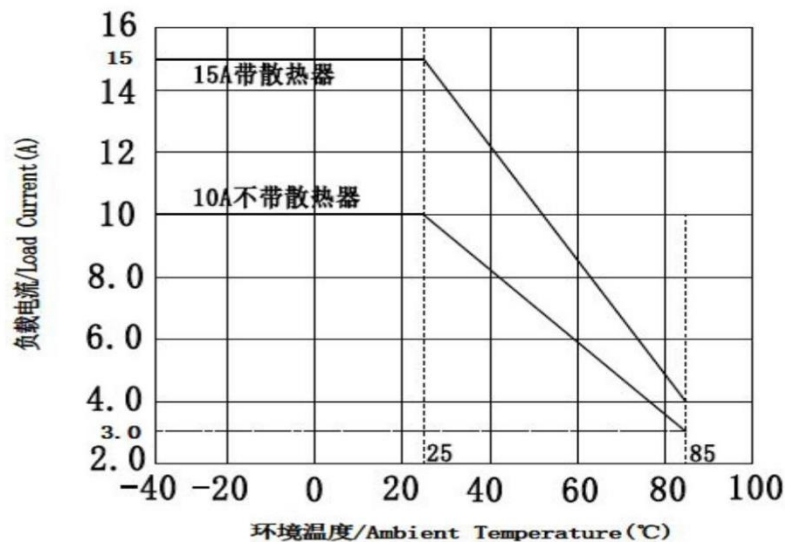

## 接通和关断时间关系 Turn on and Turn off time

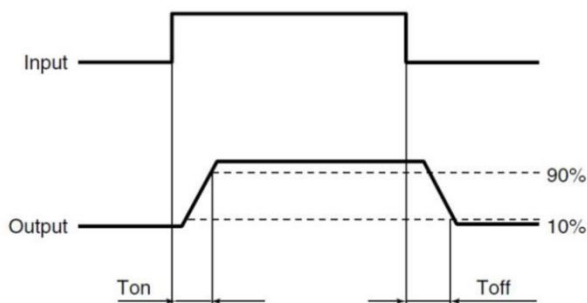



安装孔尺寸图 Fixing layout

Unit:mm

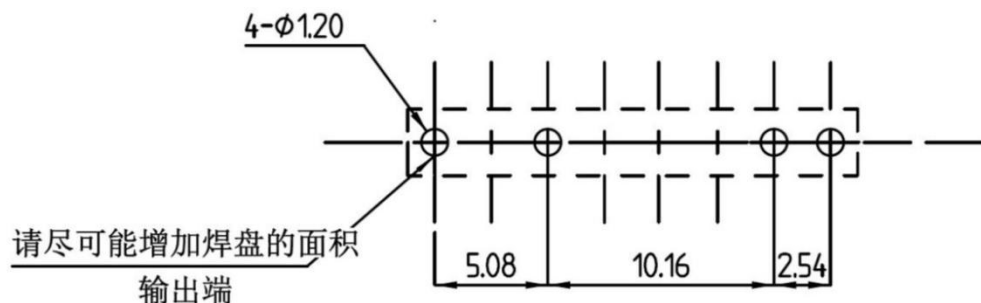

## 注意事项 Notes

a) 工作环境温度超过 25℃时请降额使用，降额曲线参考附件。

When ambient temperature is above 25℃, the load current must be reduced. (see Characteristic Data 1)

- 在 60%额定值使用时，推荐使用散热器。

The use of heat-sink is recommended, when current is more than 60% rating value.

- 请务必在输出端布线时尽量增加铜箔的面积和焊锡的厚度，以确保散热符合要求！

In order to get the enough heat sink, please make maximum copper width, and enough thickness of solder at output layout.

b) 继电器接线时，务必保证输入端极性的正确，以免损坏继电器。

Ensuring the polarity is correct when connecting the input lines, otherwise the wrong connection will damage the relay.

## 关于防静电对策 Cautions for Static Electricity

a. 操作 MOS 输出继电器的作业人员，请穿戴制电性作业服，通过 500kΩ~1MΩ 左右的保护电阻，实施人体接地。

a. Employees handling relays should wear anti-static clothing and should be grounded through protective resistance of 500kΩ to 1MΩ.

b. 请在作业台上粘贴带导电性的金属板或具有防静电的专用板，并对测量仪器和治具等实施接地。

b. A conductive metal sheet should be placed over the work table. Measuring instruments and jigs should be grounded.

c. 使用电烙铁时，对电烙铁前端进行接地。（建议使用低电压用的电烙铁。）

c. When using soldering irons, either use irons with low leakage current, or ground the tip of the soldering iron. (Use of low-voltage soldering irons is also recommended.)

d. 组装时使用的设备等也应正确地接地。

d. Devices and equipment used in assembly should also be grounded.

e. 对印刷电路板和机器进行包装时，请避免使用发泡苯乙烯、聚乙烯等带电性的高分子材料。

e. When packing printed circuit boards and equipment, avoid using high-polymer materials such as foam styrene, plastic, and other materials which carry an electrostatic charge.

f. 对MOS输出继电器进行储存和搬运时，请在不易产生静电的环境(例如湿度45~60%)中通过导电性包装材料进行保护。

f. When storing or transporting relays, the environment should not be conducive to generating static electricity (for instance, the humidity should be between 45 and 60%), and relays should be protected using conductive packing materials.