

SCHEMATIC

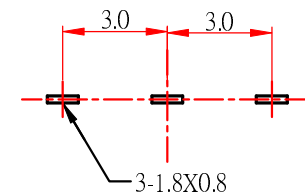
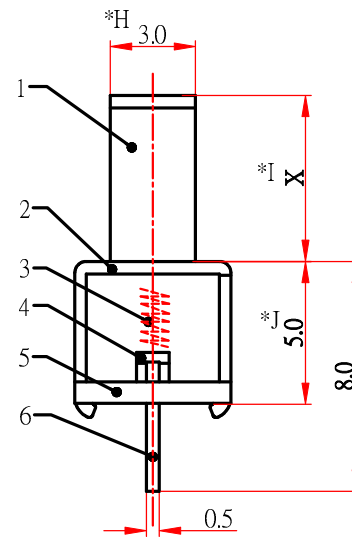
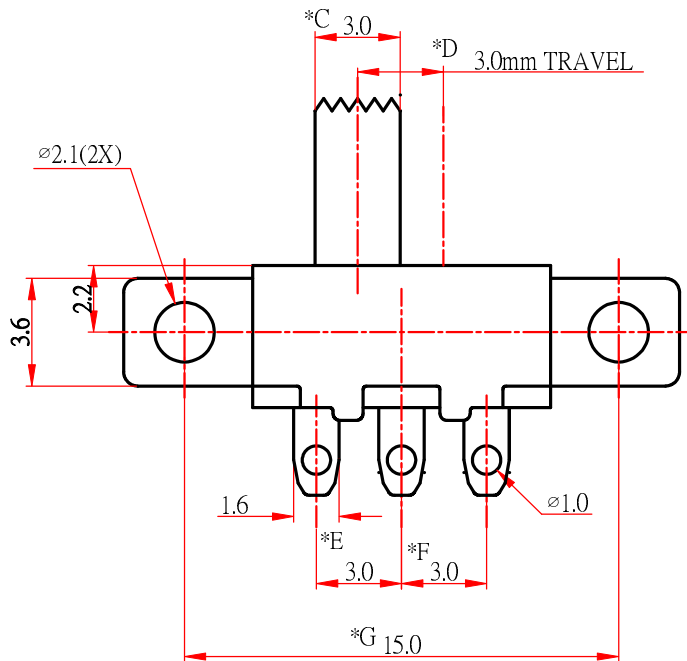

P.C.B.LAYOUT

\* CRITICAL DIMENSION

CHI FUNG ELECTRONICS CO.,LTD.

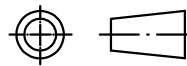

SERIES : SLIDE SWITCH  
 PART NAME: SSV-12F55-GX  
 UNIT : M M  
 SCALE : 4 : 1  
 REV : A/0

DRAWING NO: CF-ENL-SSV4209  
 GENERAL TOLERANCE  
 WITHIN 0.XXmm?.15mm  
 OVER 0.Xmm?.25mm

6	TERMINAL	BRASS	3	Ag COATING
5	BASE	PHENOLIC RESIN	1	NATURAL
4	CONTACT	COPPER STRIP	1	Ag CLAD
3	SPRING	STEEL WIRE	1	TEMPER
2	FRAME	STEEL STRIP	1	BLACK
1	KNOB	POM	1	BLACK
NO.	PART NAME	MATERIAL	QTY	FINISHING

1

2

3

4