

技术说明:  
 1、未注公差尺寸的极限偏差按GB/T 14486-MT6级;  
 2、制件应饱满光滑、色泽均匀;  
 3、无缩痕、裂纹、银丝等缺陷;  
 4、未注壁厚3; 未注筋板1.5~2;  
 5、未注过渡圆角取R0.3~R1, 脱模斜度≤0.3° ;

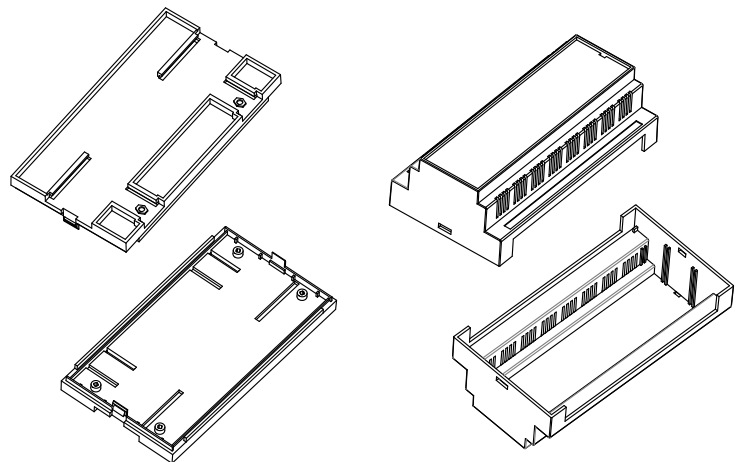
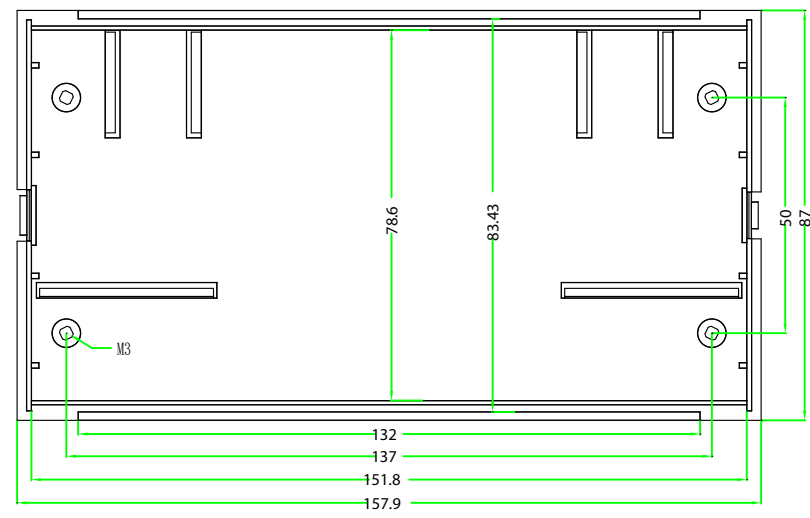
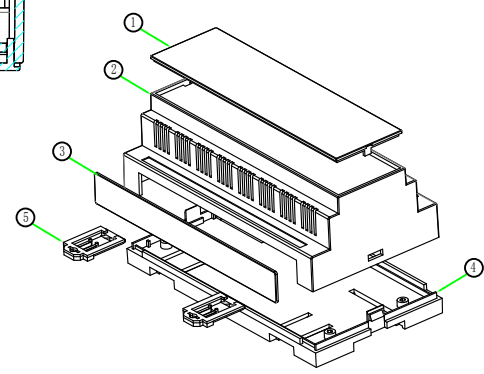

表面处理	*****	AK80005-B1	图号	AK80005-B1
制图日期			材料	*****
备注	*****		数量	N件
		比例	1:1	
第 页	共 页	<b>SZOMK</b>		