

REVISION RECORD				
REV	ECN	DESCRIPTION	DRFT	DATE

NOTES1:

UL Standard

- Rated Voltage/Current : 600V / 60A
- Withstanding Voltage : AC2200V/1Min.
- Torque Value : M4 , 10.53Lb.in
- Wire Range : 20~6AWG

IEC Standard

1.

Pollution Degree	3
Overvoltage Category	III
Rate Impulse Voltage(KV)	8.0KV
Rate Voltage(V)	1000V
Rate Current(A)	57A

- Torque Value : M4 , 1.2N.m
- Wire Range : 0.5~10mm²

NOTES2:

- Dimension shall be interpreted per ASME Y14.5-2009
- Pitch : 10.0mm, Poles : 01P
- Stripping length : 11-12mm
- Operating temperature: -40°C~+105°C
- Undimensioned Tolerances:

Pitch Range In mm		Nominal Dimension Range In mm						-	∩	∇
TO	Over	TO	Over	TO	Over	TO	Over	0.1/10	<	
6	10	10	24	30	60	100	150			
±0.15	±0.20	±0.30	±0.30	±0.50	±0.70	±1.00	±1.30		±2°	

6.RoHS Compliance

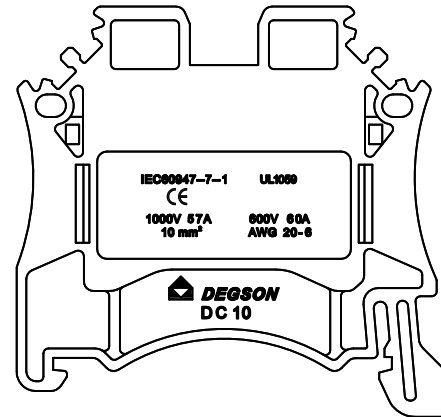
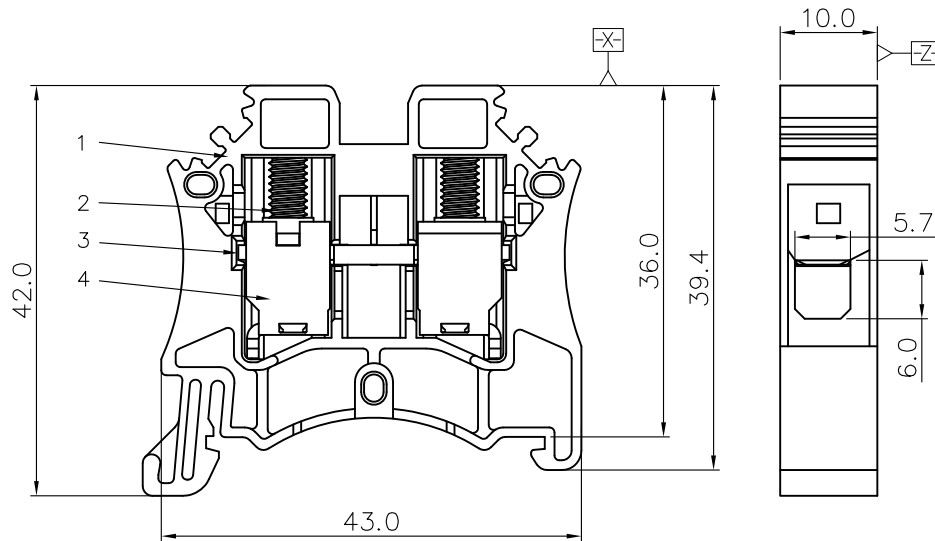
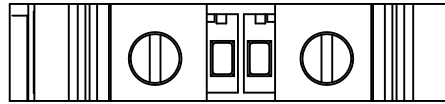

4	GAGE	2	STEEL	M4/Zn PLATED
3	CURRENT CARRIER	1	COPPER ALLOY	Sn PLATED
2	SCREW	2	STEEL	M4/Zn PLATED
1	HOUSING	1	PA66	UL94V-0
ITEM	NAME OF PART	Q"TY	MATERIAL	NOTES

DETACHED LISTS	PART NO.:	/		
	APPD:	NAME: DEGSON ® NINGBO DEGSON ELECTRICAL CO., LTD		
	CHKD:	DC10-01P-1Y-00A(H)		
	DRFT: ding 2015/10/29	TITLE: CUSTOMER DRAWING	REV	D0-1
		DRAWING NO.: DC10-C01	SHEET	1/1
	THIRD ANGLE PROJECTION	MM (INCH)	DO NOT SCALE DRAWING	SCALE 1:1