

REVISION RECORD

REV	ECN	DESCRIPTION	DRFT	DATE

H
G
F
E
D
C
B
A

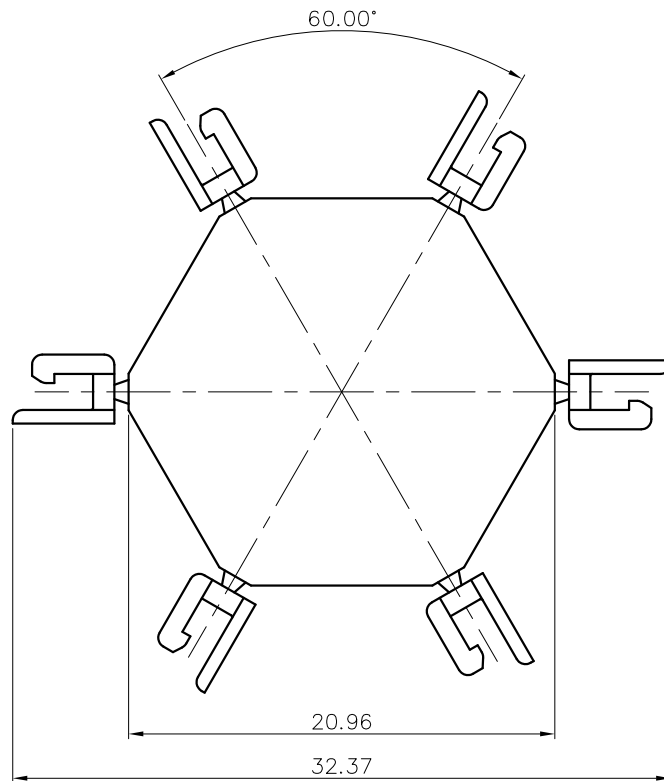

NOTES:

- 1.Dimension shall be interpreted per ASME Y14.5-2009
- 2.Poles : N=06P
- 3.Undimensioned tolerances:

Pitch range in mm		Nominal dimension range in mm					0.1/10	0.1/10
TO	Over	TO	TO	TO	TO	TO	0.1/10	
6	6 TO 10	10 TO 24	30 TO 30	60 TO 60	100 TO 100	150 TO 150	<	
±0.15	±0.20	±0.30	±0.30	±0.50	±0.70	±1.00	±1.30	
							±2'	

4.RoHS Compliance

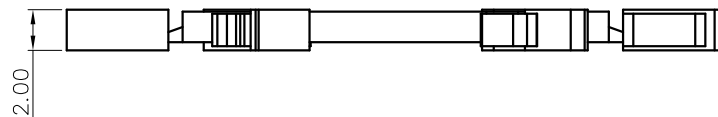
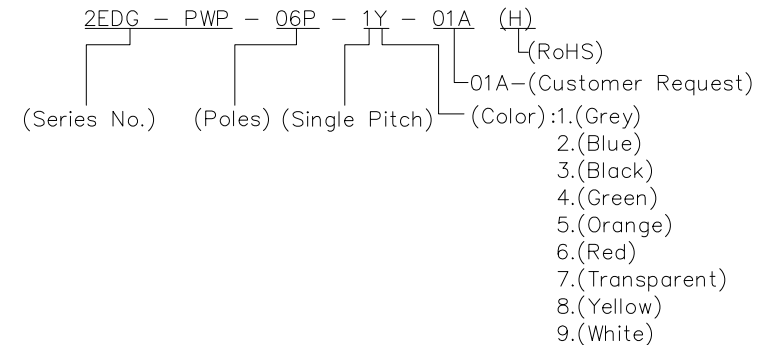

DETACHED LISTS	PART NO.:	/			宁波高松电子有限公司 NINGBO DEGSON ELECTRICAL CO., LTD	
	APPD:	/	NAME: 2EDG-PWP-06P-1Y-01A(H)			
	CHKD:	/	TITLE: CUSTOMER DRAWING			
	DRFT:	/	DRAWING NO.:		REV	DO
		MM (INCH)		SHEET	1/1	
THIRD ANGLE PROJECTION				DO NOT SCALE DRAWING	SCALE	1:1

H
G
F
E
D
C
B
A